



Ulis Motorradladen

BMW Motorcycles Spare Parts Accessory

PARTS CATALOGUE Winter 2020

BMW R50/5-R80GS Basic 1969 -1996

Table of content:

<i>Terms and Conditions</i>	3
<i>Impressum</i>	5
<i>Group 11a Engine</i>	6
<i>Group 11b Engine</i>	13
<i>Group 12 Engine electric</i>	16
<i>Group 13a Fuel system</i>	19
<i>Group 13b BING carburator R50/5-R60/7</i>	21
<i>Group 13c Bing carburator R75/-R100</i>	24
<i>Group 13d Dellorto carburator R90S</i>	28
<i>Group 16 Fuel tank</i>	30
<i>Group 18 Exhaust system</i>	33
<i>Group 21 Clutch</i>	36
<i>Group 23a FourSpeed gearbox</i>	38
<i>Group 23b FiveSpeed gearbox</i>	41
<i>Group 26 Swingarm and drive shaft</i>	44
<i>Group 31 Fork</i>	46
<i>Group 32 Steering and handlebar</i>	52
<i>Group 33 Rear axle</i>	56
<i>Group 34 Brake</i>	60
<i>Group 36 Wheels</i>	65
<i>Group 46a Frame, fenders, baggage carrier</i>	69
<i>Group 46b Fairing</i>	75
<i>Group 52 Seat</i>	79
<i>Group 61 Electric system</i>	82
<i>Group 63 Light</i>	87
<i>Group 95 Literature, bits and pieces</i>	90
<i>Credit card direct debit authorisation</i>	93
<i>How to find us</i>	94

Ulis Motorradladen GmbH
Gutleutstrasse 144
D-60327 Frankfurt am Main
Germany

Telephone +49 (0) 69 / 1753644-0
Telefax +49 (0) 69 / 1753644-99
Info@UlisMotorradladen.de
www.UlisMotorradladen.de
www.UlisMotorradladen.com

Shop is open:

Tuesday - Friday 10:00 - 12:30 and 13.30 – 18.00
Saturday 10:00 - 13:00, Sunday and Monday we're closed



The direct line to your needs

At the times indicated, the responsible employees deal exclusively with your calls. That enough lines are free and therefore longer waiting times are avoided, please call always the fitting number for your needs from the following overview.

Sale - spare parts - The Hotline for your orders!

Tuesday - Friday: 10.00 a.m. to 12.00 noon and 3.00 p.m. to 5.00 p.m.

Saturday : 10.00 a.m. to 1.00 p.m.

Tel.: 0049 (0) 69-1753644-10

Technical consulting - Technical questions about our products

Tuesday - Friday: 5.00 p.m. to 5.30 p.m.

Tel.: 0049 (0) 69-1753644-30

Ebay settlement - with questions about a purchase on Ebay

Tuesday - Friday: 10.00 a.m. to 12.00 noon

Tel.: 0049 (0) 69-1753644-11

IT / Online Store - login problems or questions regarding the use

Tuesday - Friday: 10.00 a.m. to 12.00 noon and 3.00 p.m. to 5.00 p.m.

Tel.: 0049 (0) 69-1753644-42

Additional departments

Tuesday - Friday: 10.00 a.m. to 12.00 noon and 3.00 p.m. to 5.00 p.m.

Switchboard

Here you can call if you are not sure which department is responsible for your concern. They connect you to the appropriate contact person.

Tel.: 0049 (0) 69-1753644-0

Shipping

For questions about a package which is on the way to you, the employees can help you here.

Tel.: 0049 (0) 69-1753644-12

Repairs/Workshop

If you want to repair a motorcycle or parts thereof, or have a bike/part with us for repair, you can contact us with your concerns here.

Tel.: 0049 (0) 69-1753644-31

Purchase

If you are a supplier of us, or want to be, that's the correct number:

Tel.: 0049 (0) 69-1753644-20

Accounting

For questions about a payment or reminder you can call here:

Tel.: 0049 (0) 69-1753644-41

Fax: 00 49 (0)69 - 1753644-99

E-Mail: Info@UlisMotorradladen.de



Dear BMW friends and riders,

Welcome to Ulis Motorradladen!

Thank you for your interest in our products for older BMW motorcycles. This is our latest edition of an English version of our catalog and even though it is not complete, we hope this edition will help you locate your parts more easily. Parts descriptions are now translated in English language. We apologize for mistakes beforehand.

A note to owners of BMW motorcycles built before 1969: We stock nearly all spare parts for these models and we have a catalog for them exclusively. All catalogs are available for download from our website as pdf files.

In this catalog you'll see each part category preceded by a diagram. By cross-referring a part description with its picture in the diagram, we hope to eliminate misunderstandings and incorrect part orders. The diagrams and listings also show that we do indeed keep all parts for old BMWs in stock and ready for shipment.

Please notice that we offer many used parts. We do not sell junk—rather good, useable parts. For example, if you order a used crankcase breather for a R60/6, the part you receive will in no way be inferior to a new factory part. The price of a used part is generally half the price of the new part. Exceptions to this are rare parts that are no longer available.

We are a customer-oriented company. If you have technical questions regarding your BMW we are happy to answer them. We have been riding, servicing and selling old BMWs for years—we are experts regarding what we sell. We answer all inquiries in the order they are received and as soon as possible. Suggestions are always welcome!

Terms and Conditions

The shipping-cost will be charged according to the conditions displayed in a list you will find on our website under www.ulismotorradladen.de or in conjunction with an online-order you place.

The forwarder and the shipping-method we will determine for you, depending on the nature of the goods you buy. All shipments however are insured against loss.

The payment-method „COD cost on delivery“ will result in an extra fee (see shipping-cost list).

Online-orders include the shipping-cost and all additions and will be processed when you confirm the order.

Please notice:

Every order will result in shipping-cost, no matter if you order few or many items. No shipment will be transport-fee free. The shipping-cost includes the German VAT in any case, which is no error.

The average runtime within Germany is 1-5 labourdays.

The average runtime in foreign countries varies from 5-60 labourdays, depending on the destination.

Due to specific conditions in the land of the destination (holidays, weather-conditions, legal conditions) delays can occur and cannot be influenced by Uli's.

Uli's cannot guarantee that the parcel will arrive in time. The shipping-companies themselves do not guarantee the delivery within the standard-runtime, unless you do not order additional service performances.

Special shipping-performances can be ordered, resulting in additional freight-cost, such as EXPRESS-shipments our courier services. The cost and the equivalent conditions can be asked for at Uli's helpdesk.

We are capable to ship complete motorcycles, sidecars and combinations as well. Cost and delivery conditions under request.

Payment Conditions

Bankdraft:

We draw the total from your bank-account, if it is a bank in Germany. You do not have to care or worry for anything. The quickest and most convenient way to pay. Bankdraft from banks outside of Germany are not possible.

Creditcard:

Please transfer your creditcard details to us. We need the long number, expiry-date and the 3-digit security-code. Do not use email to transmit the data! Only Fax, telephone and our webshop are safe. We accept Visa-Euro-Master-Amexcard. Maestro- or bankingcards are not valid.

Prior payment

We will send an email (or Fax) to you, including an order-confirmation with a detailed list of what you buy and the total cost all together. If you transfer the money to one of our bank-accounts, the goods will be sent out without delay. Using the online-shop, you can proceed with the payment as soon as the buying process is finished. Mention the document-number, please.

Reparation of Components

If you send in components of motorcycles for reparation, please do not forget to include a detailed description of the labour you want us to perform. Without such a description, the work cannot be done.

Please clean the parts before you send them in. If you should fail to do so, we would probably have to charge an additional cleaning-fee. Pack the things carefully, many valuable parts break or get scratched due to improper packing. The letter you send with the component must also include your full name and home-address.

**Repeal**

It is your privilege as an end-customer to send back goods you have bought at Uli's, within the first 14 days after your purchase. This right is only valid if we had sent the parts to you, not if you had bought them in our shop locality. Please send your repeal within 14 days in written form (a.e. letter, fax, email), you must not declare the reason. If you received the goods before this 14 days period ends, it's enough to send the goods back.

Send the Reapeal to:

Ulis Motorradladen GmbH
Gutleutstrasse 144
60327 Frankfurt
Germany
Email: info@ulismotorradladen.de
Fax: 0049 - 69 - 1753644 - 99

You can claim back the full amount, if:

- the commodity has been bought at Uli's,
- the goods are not damaged
- the goods have not been used, regardless of minor traces of usual inspections

Parts that have been used or damaged might not be subject for a refund or for claims. In some cases, we would refund the value with an equivalent deduction.

Basically, we will refund the shipping-cost from us to you, if you return the commodities within 14 days and under the condition that you return them completely. If you should happen to keep some of the articles out of one shipment, we will probably not refund the entire shipping-cost.

If the shipment from us to you was free of charge, due to our „more than 150 Euro“-regulation, and you return goods that lower the value of the shipment below this borderline, we will probably charge shipping cost after your purchase. This may result in a deduction of the refund value through Uli's.

We gladly cover your return-shipping-cost if:

- the return takes place not later than 14 days after the purchase
- the overall value of the parts you had returned exceeds 40,00 Euro
- the invoice has completely been paid for

The return-shipping-cost will not be covered by Uli's if these conditions are not matched.

No Repeal for bussiness customers, clubs and societys.

If you have the wish to send back goods, please ask us before!

No Repeal if you bought the good in our local shop.

If you have the wish to send back goods, please ask us before!

Exchange

The condition for an exchange of a commodity is that the goods have returned to Uli's.

The goods you return will be subject to a credit, and the parts you want to buy instead will be charged as usual.

Reclamation

Everything you buy at Uli's includes „Gewährleistung“, which means that you have the right to claim a broken, defective or unfunctional product at Uli's up to a period of 24 months, but only if we had sent the part to you. If you had picked up the commodity in our shop locality, the right is invalid.

The right mentioned above is valid 12 months only if the commodity is secondhand.

Of course we inspect all secondhand and used parts throughly before we sell them.

In case of a righteous reclamation of goods, Uli's will cover all transportation-fees, also for their return.

Your shipments to us

will be accepted under the condition that the transportation-fee has been paid for. Shipments that include a duty for Uli's will be refused. Exemptions are made if the return is subject to an agreement with Uli's.

If it should be your wish not to expend transportation-fees prior to the return, we would like you to get in contact with us.

Uli's has means to organize reasonable collect-services. If you should fail to contact us before you send in a parcel with a duty for Uli's, we would probably deduct the cost from later refunds. Please do not send „unfree“ parcels!

Prices

All pricelists in connection with Uli's Motorradladen, such as the PDF-file you find under www.ulismotorradladen.de include reserved prices. Changes in prices can and will occur. We do not guarantee for printed prices.

The prices in the online-shop are currently adopted and valid in general.



Every pricelist includes prices with VAT and without VAT. All prices are in Euro. Pricelists in other currencies than EURO do not exist. Also, the invoices we set up are in EURO exclusively.

**Best Regards,
schöne Grüße aus Frankfurt,**

Ulis Motorradladen

Impressum

Ulis Motorradladen Gmbh
BMW Motorräder – Ersatzteile – Zubehör
Gutleutstrasse 144

D-60327 Frankfurt am Main
Germany

Telefon +49 (69) 1753644-0
Telefax +49 (69) 1753644-99
eMail Info@UlisMotorradladen.de
Internet http://www.UlisMotorradladen.de

Managing director Ulrich Seiwert
District court Frankfurt HRB40289
VAT-No: / UstIdNr: DE 174059929

Payments can be transfered to:
Postgiroamt Frankfurt
Account No 11 52 38 608
Bank Id No 500 100 60
Iban: DE43500100600115238608
SwiftBic: PBNK DE FF

Commerzbank Frankfurt
Account No 384 766 400
Bank Id No 500 800 00
Iban: DE67500800000384766400
SwiftBic: DRES DE FF

Copyright @ Ulis Motorradladen GmbH 2020.
Reprint, copying or any kind of publishing – even parts of it – needs our written permission!

We apologize for all possible mistakes and price changes.



Group 11a Engine

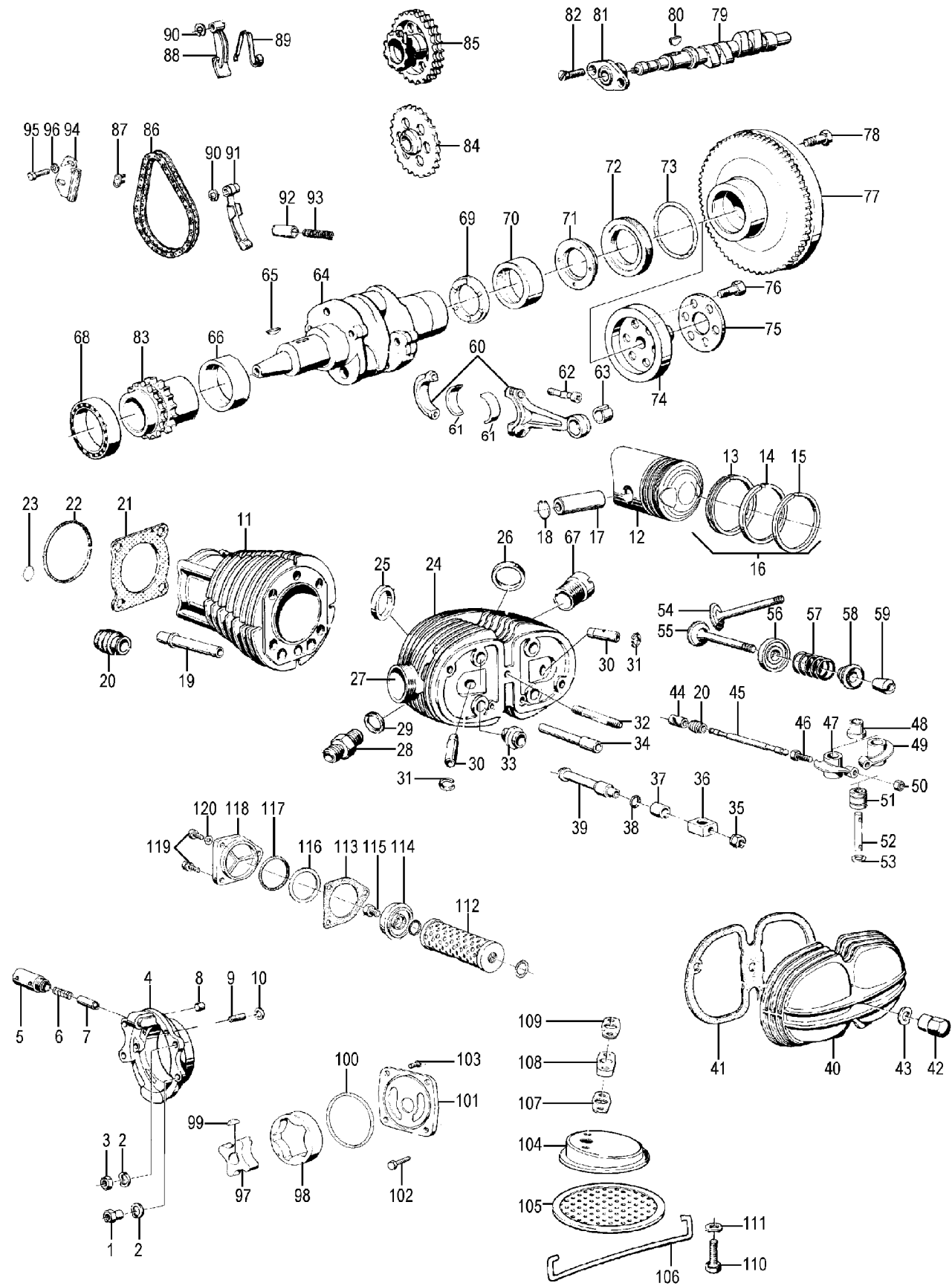

<u>Picture-No.</u>	<u>Article-No.</u>	<u>Description</u>	<u>Net</u>	<u>Gross</u>
11a_000	024570	Sealing compound (Elastic gasket grease), 40ml Hylomar M	5,13 €	6,10 €
11a_001	1253243	Nut for chain tensioner spring for BMW R50/5 and up until year of manufacture 09/1983 and for bearing cover oil pan	4,96 €	5,90 €
11a_004a	1259593	Bearing shield crank shaft for BMW R50/5-R100, front, years of manufacture 09/1969-09/1978	112,44 €	133,80 €



11a_004b	1337293	Bearing shield 09/78->, crankshaft front	150,59 €	179,20 €
11a_006	52128	Spring for relief pressure valve for BMW R50/5 and up	2,52 €	3,00 €
11a_007	71320	Piston for relief pressure valve for BMW R50/5 and up	6,72 €	8,00 €
11a_011	51383	Cylinder for BMW R75/5-R75/6 until year of manufacture 08/1975, new	346,13 €	411,90 €
11a_011	9823191	Piston and cylinder assembly for BMW R65, 27PS, 8,5:1 from year of manufacture 1985 2 cylinder with pistons complete, used	363,53 €	432,60 €
11a_011c	10013	Cylinder bore and hone job - UP TO measure 70,00mm	71,43 €	85,00 €
11a_011c	1001313	Cylinder hone job	12,18 €	14,50 €
11a_011c	3003030	Cylinder head planning job	17,31 €	20,60 €
11a_011d	10012	Cylinder bore and hone job - OVER measure 70,00mm	87,56 €	104,20 €
11a_011e	1337917	Cylinder 1000ccm NIKASIL for BMW models from year of manufacture 08/1980	399,83 €	475,80 €
11a_011g	1337275	Cylinder for BMW R65, Nicasil, new	405,97 €	483,10 €
11a_011i	1337391	Power Kit 1000cc for BMW R80 from year of manufacture 1981, 2 piston/cylinder incl. TÜV-report, 46KW/62, 5PS	713,28 €	848,80 €
11a_011i	1337392	Cylinder Replacement Kit 1000ccm for BMW models from year of manufacture 1981 two cylinder and pistons	713,28 €	848,80 €
11a_011i	1264647	Cylinder for R90S from year of manufacture 09/1975, new	266,39 €	317,00 €
11a_011i	1337389	Cylinder Replacement Kit 1000ccm for BMW models until year of manufacture 09/1980 two cylinder and pistons, NIKASIL	713,28 €	848,80 €
11a_011j	1337394	Power Kit 1000cc for BMW R75/5-R90S until year of manufacture 09/1975, 2 piston/cylinder 97mm	778,15 €	926,00 €
11a_012	1335659	Piston for BMW R60/5, R60/6 and R60/7 - 74,00mm (73,96mm) 1st oversize, complete with rings, pin and clips	225,55 €	268,40 €
11a_012	1253169	Piston for BMW R75/5, R75/6 and R75/7 - 83,50mm (83,495mm) complete with rings, pin and clips	146,30 €	174,10 €
11a_012	1255559	Piston for BMW R75/5, R75/6 and R75/7 - 82.01mm complete with rings, pin and clips	146,30 €	174,10 €
11a_012	1255560	Piston for BMW R75/5, R75/6 and R75/7 - 82.02mm complete with rings, pin and clips	146,30 €	174,10 €
11a_012	1253167	Piston for BMW R75/5, R75/6 and R75/7 - 83,00mm complete with rings, pin and clips	146,30 €	174,10 €
11a_012	1337261	Piston for BMW R65, R65T and R65LS, 1:9.2 - 82,00mm (81,97mm) Nikasil, complete with rings, pin and clips	173,03 €	205,90 €
11a_012	1335658	Piston for BMW R60/5, R60/6 and R60/7 - 74,50mm (74,46mm) 2nd oversize, complete with rings, pin and clips	195,38 €	232,50 €
11a_012	1254053	Piston for BMW R50/5 - 67,00mm, complete with rings, pin and clips standard measure	160,17 €	190,60 €
11a_012	1335656	Piston for BMW R60/5, R60/6 and R60/7 - 73,50mm (73,46mm) standard measure, complete with rings, pin and clips	190,42 €	226,60 €
11a_012	1255556	Piston for BMW R90/6, 1:9,0 - 89,985mm, complete with rings, pin and clips standard measure	172,27 €	205,00 €
11a_012	1259871	Piston for BMW R90S - 90,00mm, complete with rings, pin and clips standard measure	190,34 €	226,50 €
11a_012	1335042	Piston for BMW R45 1:9.2 - 70,00mm, complete with rings, pin and clips standard measure for cast-iron sleeve	186,05 €	221,40 €
11a_012	1335045	Piston for BMW R45 1:9.2 - 70,25mm, complete with rings, pin and clips for cast iron sleeve, 1st oversize	155,71 €	185,30 €
11a_012	1335062	Piston for BMW R45 1:9.2 - 70,50mm, complete with rings, pin and clips for cast iron sleeve, 2nd oversize	229,24 €	272,80 €
11a_012	1335463	Piston for BMW R100S, R100RS and R100RT, 1:9,5 - 94,25mm for cast-iron sleeve, complete with rings, pin and clips	176,72 €	210,30 €
11a_012	1335464	Piston for BMW R100S, R100RS and R100RT, 1:9,5 - 94,50mm for cast-iron sleeve, complete with rings, pin and clips	180,92 €	215,30 €
11a_012	1338058	Piston for BMW R65 and R65GS, 1:8,4, complete with rings, pin and clips 27PS, for Nicasil-barrel	147,06 €	175,00 €
11a_012	1335049	Piston for BMW R65, 1:9.2 - 82,00mm, complete with rings, pin and clips 45PS, for cast-iron sleeve	152,52 €	181,50 €
11a_012	1253161	Piston for BMW R75/5, R75/6 and R75/7 - 82.00mm (81,965mm) complete with rings, pin and clips	146,30 €	174,10 €
11a_012	1253163	Piston for BMW R75/5, R75/6 and R75/7 - 82.50mm 2nd oversize, complete with rings, pin and clips	172,18 €	204,90 €
11a_012	1335066	Piston for BMW R65, 1:9.2 - 82,50mm, complete with rings, pin and clips 45PS, for cast-iron sleeve	152,44 €	181,40 €
11a_012	1335339	Piston for BMW R45N, (27PS) 1:8,2 - 70,50mm, complete with rings, pin and clips for cast iron sleeve, 2nd oversize	155,71 €	185,30 €
11a_012	1335462	Piston for BMW R100S, R100RS and R100RT, 1:9,5 - 94,00mm for cast-iron sleeve, complete with rings, pin and clips	181,68 €	216,20 €
11a_012	1254054	Piston for BMW R50/5 - 67,50mm (67,48mm), complete with rings, pin and clips 1st oversize	209,33 €	249,10 €
11a_012	1335333	Piston for BMW R45N, (27PS) 1:8,2 - 70,00mm, complete with rings, pin and clips for cast iron sleeve, standard measure	155,71 €	185,30 €
11a_012	1335338	Piston for BMW R45N, (27PS) 1:8,2 - 70,25mm, complete with rings, pin and clips for cast iron sleeve, 1st oversize	155,71 €	185,30 €
11a_012	1259875	Piston for BMW R90S - 90,50mm (90,475mm), complete with rings, pin and clips 1st oversize	200,00 €	238,00 €
11a_012	1337175	Piston for BMW R100S, R100RS and R100RT, 1:9,5 - 94,00mm, Nicasil complete with rings, pin and clips	232,35 €	276,50 €
11a_012	1254055	Piston for BMW R50/5 - 68,00mm, complete with rings, pin and clips 2nd oversize	173,03 €	205,90 €



11a_014	1254339	Piston ring for BMW R50/5 - 68,00mm, compression 2nd ring	8,24 €	9,80 €
11a_015	1014547	Piston ring - 73,50mm, compression 1st ring, chrome plated, 1,75mm	8,07 €	9,60 €
11a_015	1254341	Piston ring for BMW R50/5 - 67,50mm, oil scraper ring	10,59 €	12,60 €
11a_015	1254342	Piston ring - 68,00mm, oil scraper ring also for BMW R50/5	10,59 €	12,60 €
11a_015a	1245363	Piston ring for BMW R60/5 and R60/6 - 74,50mm, compression 1st ring	8,24 €	9,80 €
11a_015b	1245365	Piston ring for BMW R60/5 and R60/6 - 74,50mm, compression 2nd ring	8,24 €	9,80 €
11a_015c	1245367	Piston ring for BMW R605 and R60/6 - 74,50mm, oil scraper ring	10,59 €	12,60 €
11a_016	1265505	Piston ring set for BMW R100 until year of manufacture 1981 - 94,00mm for cast iron barrel, standard measure	36,30 €	43,20 €
11a_016	1335217	Piston ring set for BMW R80/7, years of manufacture 1977-1980 - 84,80mm standard measure	31,34 €	37,30 €
11a_016	1335218	Piston ring set for BMW R80/7, years of manufacture 1977-1980 – 84,80+0,25mm 1st oversize	30,50 €	36,30 €
11a_016a	1256470	Piston ring set for BMW R50/5 - 67,00mm standard measure	50,67 €	60,30 €
11a_016a	1335219	Piston ring set for BMW R80/7, years of manufacture 1977-1980 – 84,80+0,50mm 2nd oversize	37,14 €	44,20 €
11a_016ac	1256472	Piston ring set for BMW R50/5 - 68,00mm 2nd oversize	37,14 €	44,20 €
11a_016b	1337399	Piston ring set for BMW R100 from year of manufacture 09/1980 - 94,00mm Nicasil	28,74 €	34,20 €
11a_016b	1337400	Piston ring set for BMW R45 from year of manufacture 09/1980 - 70,00mm Nicasil	50,67 €	60,30 €
11a_016c	1335284	Piston ring set für BMW R45 - 70,00mm standard measure	36,30 €	43,20 €
11a_016d	1337398	Piston ring set for BMW R80 from year of manufacture 1981 - 84,80mm for Nicasil	38,91 €	46,30 €
11a_016d	1335285	Piston ring set for BMW R45 - 70,25mm 1st oversize	50,67 €	60,30 €
11a_016e	1265506	Piston ring set for BMW R100 until year of manufacture 09/1980 - 94,25mm for cast iron barrel, 1st oversize	34,54 €	41,10 €
11a_016f	1256477	Piston ring set for BMW R65 and R75/5-R75/7 - 82,00mm standard measure	40,42 €	48,10 €
11a_016g	1256478	Piston ring set for BMW R65 and R75/5-R75/7 - 82,50mm 1st oversize	30,50 €	36,30 €
11a_016h	1259854	Piston ring set for BMW R90/6 and R90S - 90,50mm 1st oversize	38,07 €	45,30 €
11a_016h	1256479	Piston ring set for BMW R65 and R75/5-R75/7 - 83,00mm 2nd oversize	37,14 €	44,20 €
11a_016i	1259855	Piston ring set for BMW R90/6 and R90S - 91,00mm 2nd oversize	38,91 €	46,30 €
11a_016j	1259853	Piston ring set for BMW R90/6 and R90S - 90,00mm standard measure	38,99 €	46,40 €
11a_016l	1337401	Piston ring set for BMW R65 - 82,00mm for Nicasil	50,67 €	60,30 €
11a_016n	1265507	Piston ring set for BMW R100 until year of manufacture 1981 - 94,50mm 2nd over size, for cast iron barrel	34,54 €	41,10 €
11a_016o	1256473	Piston ring set for BMW R60/5-R60/7 - 73,50mm standard measure	31,34 €	37,30 €
11a_016p	1256474	Piston ring set for BMW R60/5-R60/7 - 74,00mm 1st oversize	31,34 €	37,30 €
11a_017	1335474	Piston pin for BMW R80/7-R100RT until year of manufacture 1995 22x13x74,31mm	22,69 €	27,00 €
11a_017	1257078	Piston pin for BMW R75/5 22x18x69mm - for racing use, extra light	28,91 €	34,40 €
11a_017	1253170	Piston pin for BMW R75/5, R75/6 and R75/7 22x14x69mm	28,91 €	34,40 €
11a_017a	1254333	Piston pin for BMW R50/5 22x15x54mm	21,60 €	25,70 €
11a_018a	9934460	Piston pin retainer for BMW R45, R50/5-R90/6, R65 and R65GS 22mm	0,84 €	1,00 €
11a_018b	1335476	Piston pin retainer - 22x1,75mm for BMW R80/7-R100RT, from year of manufacture 09/1977	2,35 €	2,80 €
11a_018c	1265623	Piston pin retainer for BMW R100/7 22mm	4,79 €	5,70 €
11a_019a	50214	Push rod tube for BMW R50/5-R90S until year of manufacture 08/1975 stainless steel	13,78 €	16,40 €
11a_019a	1250214	Push rod tube for BMW R50/5-R90S until year of manufacture 08/1975 zincked	25,97 €	30,90 €
11a_019b	62904	Push rod tube for BMW models from year of manufacture 08/1975 original BMW	26,22 €	31,20 €
11a_019c	35277	Push rod tube for BMW R45 and R65 stainless steel, polished	14,62 €	17,40 €
11a_019d	1262904	Push rod tube for BMW models from year of manufacture 08/1975 stainless steel	14,20 €	16,90 €
11a_020a	2032	Push rod rubber seal for BMW R50/5-R90S until year of manufacture 09/1975	1,93 €	2,30 €
11a_020b	35090	Push rod rubber seal for BMW R45 and R65	2,94 €	3,50 €
11a_020c	3032	Push rod rubber seal for BMW R60/6-R100 from year of manufacture 08/1975	1,93 €	2,30 €
11a_021	1261672	Cylinder head gasket for BMW R50/5-75/7, R90/6, R90S, R45/R65 and R80-R80GS	7,56 €	9,00 €
11a_021	1338715	Cylinder head gasket for BMW R100 and ONLY FOR R80-Egypt until year of manufacture 1985	7,73 €	9,20 €
11a_021a	55002	Cylinder base gasket for BMW R50/5-R100, R45 nd R65 made of special seal paper no oil dust!!!	2,77 €	3,30 €
11a_021b	1255001	Cylinder base gasket for BMW R50/5-R100 until year of manufacture 08/1976, aluminium, 1,15mm	2,35 €	2,80 €
11a_021c	1335650	Cylinder base gasket, 96"ROZ" for BMW R60 and R60/7 from year of manufacture 09/1976 lowering compaction, aluminium, 0,6mm	7,90 €	9,40 €
11a_021d	1257092	Cylinder base gasketfor BMW R50/5, R60/5 and R75/5 until year 08/1976, aluminium, 1,15mm	3,03 €	3,60 €
11a_022a	337567	O-ring cylinder base for BMW R60/6-R100, big 93,0 x 2,2mm (replaced 93,0 x 2,0mm)	2,94 €	3,50 €
11a_023	62141	O-ring cylinder base for BMW R60/6-R100, small	0,67 €	0,80 €
11a_024	65176	Cylinder head for BMW R100RS until year of manufacture 09/1981, left side, new WITHOUT valve (for Ø 40mm carburettor)	389,83 €	463,90 €
11a_024	1262960	Cylinder head for BMW R60/5 and R60/6, left side, new WITHOUT valves	278,15 €	331,00 €



11a_024	35224	Cylinder head for BMW R65 until year of manufacture 1981, right side, new WITHOUT valves	293,45 €	349,20 €
11a_024	98502	Threat insert for long spark plug, for BMW R50/2, R60/2 and R69S	5,21 €	6,20 €
11a_024a	29030	Cylinder head rebuild-job for BMW R69S and R60/5-R80/7 Sent in ALL parts!	134,20 €	159,70 €
11a_024b	29032	Cylinder head rebuild-job for BMW R90/6-R100 Sent in ALL parts!	139,08 €	165,50 €
11a_024c	33030	Cylinder head rebuild-job for BMW R45/R65, complete with reinforced exhaust valves	133,95 €	159,40 €
11a_024d	1337870	Cylinder head for R80, right side, new WITHOUT valves, REMNANTS	458,74 €	545,90 €
11a_024e	1337869	Cylinder head for R80, left side, new WITHOUT valves, REMNANTS	458,74 €	545,90 €
11a_024g	35222	Cylinder head for BMW R45, right side, new WITHOUT valves, REMNANTS	242,27 €	288,30 €
11a_024h	1253158	Cylinder head for BMW R50/5, left side, new WITHOUT valves	285,55 €	339,80 €
11a_024h	32030	Cylinder head rebuild-job for BMW R45/R65 ONLY with 8mm ex-valve	101,26 €	120,50 €
11a_024i	1253155	Cylinder head for BMW R50/5, right side, new WITHOUT valves	262,86 €	312,80 €
11a_024m	1262852	Cylinder head for BMW R90S, right side, new WITHOUT valves	432,77 €	515,00 €
11a_024n	65175	Cylinder head for BMW R100RS until year of manufacture 09/1981, right side, new WITHOUT valve (for Ø 40mm carburettor)	502,02 €	597,40 €
11a_024x	1337818	Rubber plug for cylinder head for BMW R100	2,18 €	2,60 €
11a_024z	98501	Thread insert for short spark plug	4,29 €	5,10 €
11a_025	00095	Valve seat ring replacing (ring and working time)	103,87 €	123,60 €
11a_026	2325741	Valve seat ring Exhaust for BMW R100, +0,2 unleaded	24,37 €	29,00 €
11a_026	1265647	Valve seat ring Intake for BMW R100, +0,2	22,61 €	26,90 €
11a_027	1070	Repair of exhaust thread	128,15 €	152,50 €
11a_027	1068	Repair of exhaust thread (when a rest of your old thread still exists)	110,84 €	131,90 €
11a_030	1335569	Valve guide 7mm inner / 14,30mm outer, for BMW R45 and R65 intake valve	11,85 €	14,10 €
11a_030	38709	Valve guide 7mm inner / 14,10mm outer, for BMW R45 and R65 intake valve	10,84 €	12,90 €
11a_030a	1002926	Valve guide 8mm inner / 14,26mm outer (oversize) with lock ring	12,10 €	14,40 €
11a_030a	1002910	Valve guide 8mm inner / 14,10mm outer (oversize) with lock ring	7,06 €	8,40 €
11a_030a	1002908	Valve guide 8mm inner / 14,08mm outer (oversize) with lock ring	7,06 €	8,40 €
11a_031	999003	Lock ring for valve guide, 14mm	0,34 €	0,40 €
11a_032	08142	Stud bolt valve cover for BMW R68, R69, R69S and R50/5-R100 M8x50	1,51 €	1,80 €
11a_033	1261405	Rocker arm mount spacer for BMW R60/6-R100 from year of manufacture 09/1975 and R45/R65 from 01/1985	8,57 €	10,20 €
11a_034	1250232	Push rod tube for BMW R50/5-R90S until year of manufacture 08/1975 for cylinder head, original BMW	12,02 €	14,30 €
11a_035a	36872	Washer cylinder head mount for BMW R68, R69, R69S und R50/5-R100	3,70 €	4,40 €
11a_035a	62302	Nut for cylinder head / rocker arm for BMW from year of manufacture 09/1975 and from BMW R60/7	2,18 €	2,60 €
11a_035b	63903	Nut for outer cylinder head for BMW R50/5 and up, wrench size 15	2,77 €	3,30 €
11a_035c	1261775	Nut for cylinder head / rocker arm for BMW R50/5-R90S until year of manufacture 08/1975	5,38 €	6,40 €
11a_036a	1250237	Rocker arm bracket for BMW R50/5, R60/5 and R75/5	25,29 €	30,10 €
11a_036b	1258264	Rocker arm support for BMW R60/6-R100 from 09/1975, R45, R65 from 01/1984 old version, bottom moulded	13,78 €	16,40 €
11a_036c	1337867	Rocker arm support for BMW R60/6-R100 from 09/1975, R65 and R80 from 01/1985 R65GS-R100GS from 09/1980, R100RS/RT from 01/1987, R80R, R100R, new version	14,71 €	17,50 €
11a_036d	1261773	Rocker arm bracket for BMW R60/6-R90S, years of manufacture 09/1973-09/1975	25,80 €	30,70 €
11a_036e	1337868	Washer rocker arm bracket for BMW from year of manufacture 09/1975	1,60 €	1,90 €
11a_037	1254840	Distance sleeve, rocker arm bracket for BMW R50/5-R75/5, years of manufacture 02/1970-08/1972	6,55 €	7,80 €
11a_038a	60470	O-ring rocker arm for BMW R50/5, R60/5 and R75/5	1,68 €	2,00 €
11a_040	1262250	Valve cover for BMW R65GS-R100G and R80-R100RT, right side black	67,23 €	80,00 €
11a_040	50243	Valve cover for BMW R50/5 and up Reproduction for outside screwing, WITH screws	44,03 €	52,40 €
11a_040	1262248	Valve cover for BMW R65GS-R100G and R80-R100RT, left side black	75,80 €	90,20 €
11a_040	63761	Valve cover for BMW R45/R65 and R60/7-R100, right side	60,50 €	72,00 €
11a_040	12243	Valve cover set for BMW R50/5 and up high gloss polished	160,50 €	191,00 €
11a_040	50241	Valve cover for BMW R50/5 and up Reproduction	37,06 €	44,10 €
11a_040	50240	Valve cover for BMW R50/5 and up Original BMW	79,41 €	94,50 €
11a_040	63762	Valve cover for BMW R45/R65 and R60/7-R100, left side	60,50 €	72,00 €
11a_040	3161200	Valve cover set for BMW R50/5-R100R, with dowel pins chromed	142,10 €	169,10 €
11a_041	19054	Valve cover gasket for BMW R24-R67/3, R50/R60/2 and R50/5-R100	3,28 €	3,90 €
11a_042	102001	Valve cover nut for BMW R51/3-R69S and R50/5-R100 chromed	3,45 €	4,10 €
11a_044	62638	Tappet for BMW R50/5-R100	55,88 €	66,50 €
11a_045	62907	Push rod for BMW R60/6-R100 from year of manufacture 09/1975 can also be used as alternative for BMW R50/5-R90S	37,14 €	44,20 €
11a_045c	1335088	Pushrod for BMW R45/R65LS years 1978-1985 and R65 1985-1995 REMNANTS	28,99 €	34,50 €
11a_046	34178	Valve adjusting screw for BMW R68, R69, R69S and R50/5-R100	4,29 €	5,10 €
11a_046a	2311726	Distance ring engine for BMW Models from year of manufacture 09/1969 until 08/1980	6,47 €	7,70 €



11a_048	1250239	Thrust-ring for rocker arm for BMW R50/5, 60/5 and R75/5	8,40 €	10,00 €
11a_049a	1250259	Rocker arm for BMW R50/5, R60/5 and R75/5 until year of manufacture 09/1973 intake - left side, exhaust - right side	104,62 €	124,50 €
11a_049c	1337713	Rocker arm for BMW R60/6-R100 from year of manufacture 09/1975 intake – left side, exhaust - right side	76,81 €	91,40 €
11a_049d	1337715	Rocker arm for BMW R60/6-R100 from year of manufacture 09/1975 intake – right side, exhaust - left side	64,87 €	77,20 €
11a_050	34128	Nut for valve adjusting screw	0,50 €	0,60 €
11a_051	1252628	Bushing, rocker arm for BMW R50/5-R75/5	5,88 €	7,00 €
11a_052	1251346	Rocker arm shaft for BMW R50/5, R60/5 and R75/5	33,95 €	40,40 €
11a_053	1257825	Thrust washer for rocker arm for BMW R50/5-R75/5	1,76 €	2,10 €
11a_054a	1250234	Intake valve for BMW R75/5-R100, 42mm	23,45 €	27,90 €
11a_054b	26151	Intake valve for BMW R68-R69S and R60/5-60/7, 38mm triple groove	30,67 €	36,50 €
11a_054c	1336903	Intake valve for BMW R65, 40mm 7mm shaft	43,19 €	51,40 €
11a_054d	56678	Intake valve for BMW R65, 38mm 7mm shaft	28,40 €	33,80 €
11a_054e	1253118	Intake valve for BMW R50/5, 34mm	19,92 €	23,70 €
11a_054f	1335091	Intake valve for BMW R45, 34mm 7mm and R65/20kw version	22,61 €	26,90 €
11a_054g	1261751	Intake valve for BMW R100 from year of manufacture 09/1978, 44mm and R80 (government version) Egyptian	26,64 €	31,70 €
11a_054g	1338285	Exhaust valve for BMW R80 and R100 from year of manufacture 1987, 40mm, 30°	46,13 €	54,90 €
11a_055	1337453	Exhaust valve for BMW R75/5-R80, 38mm	31,18 €	37,10 €
11a_055a	1335093	Exhaust valve for BMW R45 and R65 with 8mm-neck, 32mm	46,13 €	54,90 €
11a_055b	1253119	Exhaust valve for BMW R50/5, with 8mm-neck, 32mm	60,50 €	72,00 €
11a_055c	1336899	Exhaust valve for BMW R65 from year of manufacture 09/1980, with 7mm-neck, 34mm 37KW/50PS	33,53 €	39,90 €
11a_055c	1335094	Exhaust valve for BMW R65 until year of manufacture 09/1980, with 7mm-neck, 34mm	30,25 €	36,00 €
11a_055d	56679	Exhaust valve for BMW R68-R69S and R60/5/6/7, triple groove, 34mm	44,96 €	53,50 €
11a_055f	1257837	Exhaust valve for BMW R90 and R100, 40mm, 45°	47,56 €	56,60 €
11a_056	50233	Lower valve plate for BMW R50/5-R100, R45/R65 and for BMW R68, R69 and R69S new system	3,45 €	4,10 €
11a_057	13018	Valve spring for BMW R68, R69, R69S and R50/5-R100 new system	5,04 €	6,00 €
11a_057	12018	Valve spring set for BMW R68, R69, R69S and R50/5-R100 new system = 2 pieces	9,75 €	11,60 €
11a_058	56554	Upper valve plate for BMW R50/5-R100 and R68, R69, R69S new system	4,37 €	5,20 €
11a_059	07136	Valve keeper for BMW R45 and R65	1,01 €	1,20 €
11a_059	26724	Valve keeper for BMW R68, R69, R69S and R50/5-R100, triple groove new system	1,51 €	1,80 €
11a_060a	1338161	Conrod for BMW R45 and R65, blue	98,74 €	117,50 €
11a_060b	59739	Conrod for BMW R50/5-R100, overhauled, in exchange	57,98 €	69,00 €
11a_061a	58460	Conrod bearing shell standard size for BMW R50/5 and up you need 4 pcs. for 1 bike!	7,82 €	9,30 €
11a_061b	58419	Conrod bearing shell +0,25 for BMW R50/5 and up you need 4 pcs. for 1 bike!	7,82 €	9,30 €
11a_061c	58420	Conrod bearing shell +0,50 for BMW R50/5 and up you need 4 pcs. for 1 bike!	7,82 €	9,30 €
11a_061d	58421	Conrod bearing shell +0,75 for BMW R50/5 and up you need 4 pcs. for 1 bike!	10,50 €	12,50 €
11a_062	50196	Conrod screw for BMW R50/5 and up	5,38 €	6,40 €
11a_063	38456	Piston pin bushing for BMW R50/5-R100 from year of manufacture 09/1969 22mm	8,57 €	10,20 €
11a_064a	80303	Costs for repair of bad bearing seat	91,76 €	109,20 €
11a_064b	1336439	Crankshaft for BMW R45 and R65 NEW	689,92 €	821,00 €
11a_064b	1336438	Crankshaft for R45/65 in exchange	406,72 €	484,00 €
11a_064c	1336774	Crankshaft for BMW R50/5, R60/5 and R75/5 WITHOUT plugs, WITHOUT conrod, IN EXCHANGE	546,22 €	650,00 €
11a_064d	338171	Crankshaft for BMW R60/6-R100 from year of manufacture 09/1975 without conrod, threat: M11x1.5, IN EXCHANGE	406,72 €	484,00 €
11a_064e	1338172	Crankshaft for BMW R60/6-R90S until year of manufacture 09/1975 without conrod, threat: M10x1, NEW	1.166,97 €	1.388,70 €
11a_064e	0038172	Crankshaft for BMW R60/6-R100/7 from year of manufacture 09/1975 without conrod, threat: M10x1, IN EXCHANGE	406,72 €	484,00 €
11a_064f	1338171	Crankshaft for BMW R60/6-R100/7 from year of manufacture 09/1975 without conrod, thread: M11x1.5, NEW	1.421,60 €	1.691,70 €
11a_065	51480	Woodruff key crank shaft R51/2-R100, front	1,60 €	1,90 €
11a_066a	1250155	Crankshaft main bearing for BMW R50/5-R100, standard, red	58,40 €	69,50 €
11a_066b	1254788	Crankshaft main bearing for BMW R50/5-R100, +0.25mm	58,40 €	69,50 €
11a_066c	1254789	Crankshaft main bearing for BMW R50/5-R100, +0.50mm	47,73 €	56,80 €
11a_066d	1255288	Crankshaft main bearing for BMW R50/5-R100, +0.75mm	32,52 €	38,70 €
11a_066e	1265437	Crankshaft main bearing for BMW R50/5-R100, standard, green	58,40 €	69,50 €
11a_066f	1255285	Crankshaft main bearing for BMW R50/5-R100, standard, blue	58,40 €	69,50 €
11a_067a	51598	Screw socket cylinder head for BMW R50/5, R60/5, R60/6 and R60/7	38,91 €	46,30 €
11a_067b	57396	Screw socket cylinder head for BMW R75/5-R100 25mm long, for 32 carburetors	34,54 €	41,10 €
11a_067c	1262620	Screw socket cylinder head for BMW R80 and R100S-R100RS years of manufacture 1976-1984	21,60 €	25,70 €



11a_067c	1259819	Screw socket cylinder head for BMW R90S	15,71 €	18,70 €
11a_068	9981722	Bearing chain wheel crank shaft for BMW R50/5 and up	13,87 €	16,50 €
11a_069a	1256974	Thrust washer crankshaft for BMW R50/5-R100 blue, 2,53-2,578	35,46 €	42,20 €
11a_069b	1256976	Thrust washer crankshaft for BMW R50/5-R100 yellow, 2,626-2,673	33,11 €	39,40 €
11a_069c	1256975	Thrust washer crankshaft for BMW R50/5-R100 green, 2,578-2,626	35,46 €	42,20 €
11a_069d	1256973	Thrust washer crankshaft for BMW R50/5-R100 red, 2,483-2,53	33,11 €	39,40 €
11a_072	61739	Radial seal ring, crankshaft rear for BMW R50/5-R100, Teflon	16,39 €	19,50 €
11a_072a	38342	Radial seal ring, crankshaft rear for BMW R50/5-R100, rubber	13,53 €	16,10 €
11a_073	37099	O-ring fly wheel for BMW R60/6-R100	3,95 €	4,70 €
11a_074	1337284	Crankshaft jacket, rear, 80->	85,46 €	101,70 €
11a_077	38722	Fly wheel for BMW-models from year of manufacture 1981 light clutch with gear ring	151,34 €	180,10 €
11a_077b	1262070	Fly wheel for BMW R60/6-R90S from year of manufacture 09/1975 M11x1,5	218,91 €	260,50 €
11a_077c	1336380	Fly wheel for BMW R60/7-R100RT until year of manufacture 09/1980 heavy version	220,67 €	262,60 €
11a_078	16759	Fly wheel screw for BMW R50/5, 60/5 and R75/5 M10 x 1 x 24	4,96 €	5,90 €
11a_078b	57796	Fly wheel screw for BMW R60/6-R90S until year of manufacture 1976 M10 x 1 x 32	13,11 €	15,60 €
11a_078c	262060	Fly wheel screw for BMW R60/6-R100 from year of manufacture 1976 M11 x 1,5	3,78 €	4,50 €
11a_079	54217	Camshaft R50/5, R60/5	151,51 €	180,30 €
11a_079b	62999	Cam shaft for BMW R60/6 and R60/7 for two area oil pump wheel	170,42 €	202,80 €
11a_079c	59264	Cam shaft for BMW R75/5, R75/6, R90/6 and R90S until year of manufacture 09/1975, 308°	216,81 €	258,00 €
11a_079d	1337843	Cam shaft for BMW R75/6-R100 years of manufacture 09/1975-09/1978, 308° and for BMW G/S from year of manufacture 09/1980, for 2 area oil pump wheel, REMNANTS	197,82 €	235,40 €
11a_079d	1258053	Cam shaft for BMW R75/5, R75/6, R90/6 and R90S until year of manufacture 09/1975, 336° Sport-cam shaft	225,13 €	267,90 €
11a_079e	1259262	Cam shaft for BMW R50/5, R60/5 and R60/6 replacement for article 54217, ONLY in connection with article 35194	160,67 €	191,20 €
11a_080	5148002	Woodruff key cam shaft for BMW R50/5 and up	1,60 €	1,90 €
11a_081	1250251	Flange bearing camshaft for BMW R50/5-R100 Only with following screws 37107!	30,17 €	35,90 €
11a_082	00869	Mounting-screw for camshaft until year of manufacture 09/1976	0,59 €	0,70 €
11a_082	63853	Mounting-screw for camshaft from year of manufacture 1976-1981	2,18 €	2,60 €
11a_082	37107	Mounting-screw camshaft for BMW R60/6-R100 until year of manufacture 1995	4,54 €	5,40 €
11a_083a	1250198	Chain wheel crankshaft, duplex for BMW R50/5-R100 until year of manufacture 09/1978	108,82 €	129,50 €
11a_083b	1335586	Chain wheel crankshaft simplex for BMW R60/7-R100, R45 and R65, years of manufacture 09/1978-08/1995	35,71 €	42,50 €
11a_084	1335588	Chain wheel, camshaft, simplex for BMW models from year of manufacture 09/1978	48,91 €	58,20 €
11a_085	1250253	Chain wheel camshaft, duplex for BMW R50/5-R100, years of manufacture 09/1969-09/1978	93,61 €	111,40 €
11a_086a	35934	Timing chain for BMW R60/7-R100 from year of manufacture 09/1978, simplex fits also for BMW R50/5-R100 until year of manufacture 08/1978	8,82 €	10,50 €
11a_086b	50258	Timing chain for BMW R50/5-R100 until year of manufacture 09/1978 Duplex with master link	22,18 €	26,40 €
11a_088	1265455	Chain tensioner, duplex for BMW R50/5 until year of manufacture 09/1978	48,57 €	57,80 €
11a_089	1253188	Chain tensioner spring for BMW R50/5 until year of manufacture 09/1978	4,62 €	5,50 €
11a_090	32841	Lock ring chain tensioner for BMW R50/5-R100 until year of manufacture 1979 and gear for BMW R60/6-R100R and R65GS-R100GS	0,59 €	0,70 €
11a_091	1338185	Chain tensioner, simplex for BMW models from year of manufacture 09/1978	8,15 €	9,70 €
11a_092	1335579	Chain tensioner pressure piston for BMW models from year of manufacture 09/1978	8,15 €	9,70 €
11a_093	1335584	Chain tensioner spring, simplex for BMW models from year of manufacture 09/1978	5,13 €	6,10 €
11a_094	1335576	Chain tensioner slide rail for BMW models from year of manufacture 09/1978	18,66 €	22,20 €
11a_095	098177	Screw M 6 x 60, cylinder-head Allen® key stainless steel	0,59 €	0,70 €
11a_095	98177	Screw M 6 x 60, cylinder-head Allen® key	0,42 €	0,50 €
11a_095	98201	Screw for chain tensioner, simplex for BMW R45/R65 and R60/7-R100, M 8 x 20, hexagon and holding screw for exhaust pipe for BMW R50-R69S	0,17 €	0,20 €
11a_096	98414	Washer M 8, DIN125, Form A cinced	0,08 €	0,10 €
11a_096a	9931684	Washer cam shaft wheel, timing chain for BMW R45/R65, R60/7-R100RT, R65GS-R100GS	0,84 €	1,00 €
11a_097a	58971	Oil pump inner wheel for BMW R50/5-R100 until year of manufacture 1979 for woodruff key (= article nr.: 51440)	44,29 €	52,70 €
11a_097b	35194	Oil pump inner wheel for BMW R60/7-R100 until year of manufacture 1979 2-area mounting plate	37,56 €	44,70 €
11a_097c	53294	Oil pump inner wheel for BMW R50/5, R60/5 and R75/5 for woodruff key (= article nr.: 51414)	31,09 €	37,00 €
11a_098	53293	Oil pump outer wheel for BMW R50/5-R100	100,50 €	119,60 €
11a_099	51414	Woodruff key cam shaft for BMW R24-27 and R51/2 and oilpump for BMW R50/5-R90S until year of manufacture 1975	1,60 €	1,90 €



11a_099a	51440	Woodruff key crank shaft for BMW R24-R27, front and chainwheel R51/2 for inner oil pump wheel for wide key (= Article-No.: 58971)	1,60 €	1,90 €
11a_100	1335896	O-ring oil pump cover for BMW R50/5-R100	3,95 €	4,70 €
11a_101	60182	Oil pump cover for BMW R50/5 and up in connection with M6x16 bolt	39,08 €	46,50 €
11a_101a	1338544	Oil pump cover for BMW R45 and R65LS-R100 from year of manufacture 09/1980	33,28 €	39,60 €
11a_102	9913499	Screw for bearing shield mounting for BMW R50-R69S, M 6 x 28	0,76 €	0,90 €
11a_103	98155	Screw for clutch 1-cylinder, also oilpump cover for BMW R60/6-R90S, M 6 x 16, hexagon	0,17 €	0,20 €
11a_107	52280	Gasket oil pump screen for BMW R50/5-R90S	1,76 €	2,10 €
11a_107	65258	Gasket oil pump screen for BMW R60/7-R100	2,10 €	2,50 €
11a_112	5048	Oil filter insert for all BMW-models without oil cooler divided	8,91 €	10,60 €
11a_112a	1337570	Oil filter insert for all BMW-models without oil cooler one-piece	8,66 €	10,30 €
11a_112b	4048	Oil filter insert for all BMW-models with oil cooler divided	9,75 €	11,60 €
11a_113	38600	Oil filter gasket for BMW R50/5-R100	0,92 €	1,10 €
11a_114a	1250285	O-ring oil filter / dip stick for BMW /5 and R45/R65	4,96 €	5,90 €
11a_115	98240	Screw M10 x 1 x 20, hexagon	0,84 €	1,00 €
11a_116	36895	Oil filter metal gasket for BMW R60/7-R100	1,93 €	2,30 €
11a_117	37098	O-ring oil filter cover for BMW R60/6-R100	1,34 €	1,60 €
11a_118	1263345	Oil filter cover from BMW /5, without oil cooler	25,21 €	30,00 €
11a_121a	1337720	Distance washer, rocker arm for BMW models from year of manufacture 09/1975, 0,20mm	2,94 €	3,50 €
11a_121b	1337719	Distance washer, rocker arm for BMW models from year of manufacture 09/1975, 0,25mm	2,77 €	3,30 €
11a_121c	1337718	Distance washer, rocker arm for BMW models from year of manufacture 09/1975, 0,30mm	2,94 €	3,50 €
11a_121d	1337721	Distance washer, rocker arm for BMW models from year of manufacture 09/1975, 0,35mm	2,94 €	3,50 €
11a_121e	1338190	Distance washer, rocker arm for BMW models from year of manufacture 09/1975, 0,50mm	2,94 €	3,50 €
11a_122	1337717	Rocker arm thrust-bearing for BMW models from year of manufacture 09/1975 plastic	5,55 €	6,60 €
11a_123	61712	Needle bearing rocker arm for BMW R60/6-R100 and R45/R65	21,93 €	26,10 €
11a_126	1336942	Rocker arm shaft for BMW R60/6-R100 from year of manufacture 09/1973 and for BMW R45 and R65 until year of manufacture 01/1985	34,79 €	41,40 €
11a_133a	63342	Oil filter tube, short, for all BMW-models without oil cooler	11,34 €	13,50 €
11a_133b	35387	Oil filter tube, long, for all BMW-models with oil cooler	15,55 €	18,50 €
11a_45d	0035088	Pushrod for BMW R45/R65LS years 1978-1985 and R65 1985-1995 used	10,34 €	12,30 €
11a_65	5148002	Woodruff key cam shaft for BMW R50/5 and up	1,60 €	1,90 €
11a_999	9056145	Gasket set Oilchange for BMW R50/5-R100 without oilcooler	3,70 €	4,40 €
11a_999	1256928	Washer tachometer-drive (RPM-drive)	3,45 €	4,10 €
11a_999	1255023	Engine gasket set (No.M11) for BMW R50/5-R90S, till year of manufacture Aug 1975, complete	82,61 €	98,30 €
11a_999	8500007	Oil cooler By-Pass connection for BMW R100R, R100RT and R100RS	2,44 €	2,90 €
11a_999	9056146	Gasket set Oilchange for BMW R50/5-R100 with oilcooler	5,21 €	6,20 €
11a_999	1338421	Engine gasket set (No.M13) für BMW R60/7-R80/7, complete	71,93 €	85,60 €
11a_999	9942050	Crankshaft main bearing holding pin for BMW R50/5-R100	1,68 €	2,00 €
11a_999	1338174	Cylinder with piston for BMW R65GS and R65, 20KW	345,29 €	410,90 €
11a_999	50158	Oil filter tube for BMW R50/5, R60/5 and R75/5	30,25 €	36,00 €
11a_999	38203	Sleeve tube for oil filter	17,23 €	20,50 €
11a_999	1338422	Engine gasket set (No.M15), R100 up from year 1976, R80 up from year 1985, complete	71,93 €	85,60 €
11a_999	1335627	Piston and cylinder assembly for BMW R80, Nicasil, 1:8,2 original BMW	619,92 €	737,70 €
11a_999	1255024	Engine gasket set (No.M12), for BMW R60/6-R90S, as off year of manufacture Sep 1975, complete	71,93 €	85,60 €
11a_999	9998215	Screw M 8 x 45, cylinder-head Allen® key	0,59 €	0,70 €
11a_999	1338423	Engine gasket set (No.M14) for BMW R45 and R65, complete	73,53 €	87,50 €
11a_999	1338425	Engine gasket set (No.M16) for BMW R100/7, R100GS, R100R, complete	74,03 €	88,10 €
11a108	65590	Oil pump distance piece for BMW R60/7-R100 until year of manufacture 09/1980 for oil pump screen, REMNANTS	4,29 €	5,10 €



Group 11b Engine

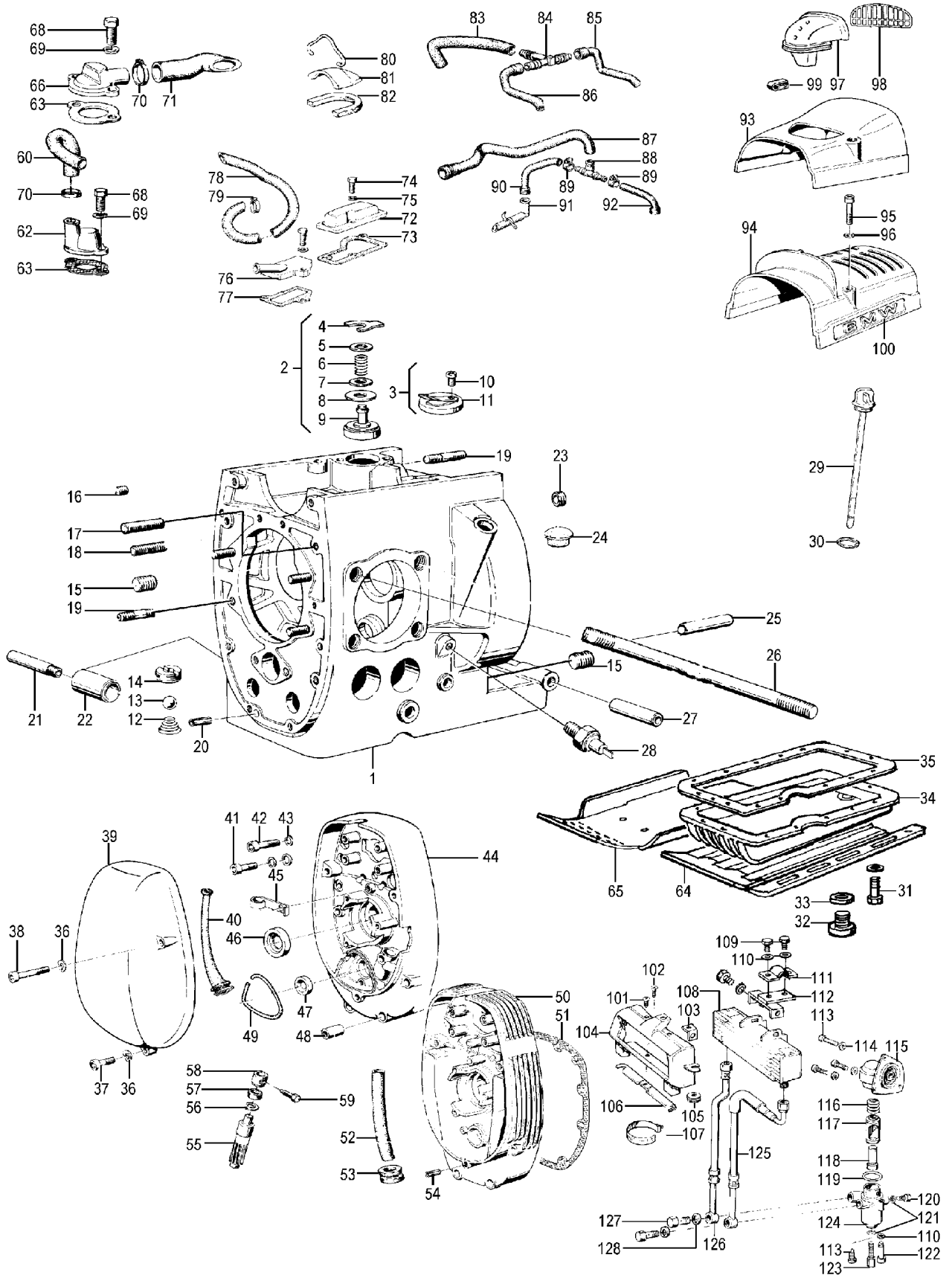

<u>Picture-No.</u>	<u>Article-No.</u>	<u>Description</u>	<u>Net</u>	<u>Gross</u>
11b_	1335870	Engine breather tube for BMW R45 and R65 until year of manufacture 09/1984 old housing form	18,66 €	22,20 €
11b_000	024570	Sealing compound (Elastic gasket grease), 40ml Hylomar M	5,13 €	6,10 €
11b_003	1335712	Engine breather for BMW R50/5-R100, new version	21,26 €	25,30 €
11b_011	35711	Diaphragm engine breather from BMW R50/5 and up	1,93 €	2,30 €



11b_012	1259879	Piston for BMW R90S - 91,00mm (90,985mm +1,0), complete with rings, pin and clips 2nd oversize	190,34 €	226,50 €
11b_012z	1258294	Piston for BMW R90/6, 1:9,0 - 90,475mm, complete with rings, pin and clips 1st oversize	205,46 €	244,50 €
11b_012z	1258295	Piston for BMW R90/6, 1:9,0 - 90,485mm, complete with rings, pin and clips 1st oversize	200,25 €	238,30 €
11b_013	86280	Ball for fork bolt for BMW R50/5, R60/5 and R75/5	0,50 €	0,60 €
11b_017	1252310	Stud bolt generator cover / engine housing for BMW R45/R65 and R50/5-R100	1,51 €	1,80 €
11b_024a	01106	Rubber plug for timing control hole, black for BMW R25-R69S and R50/5-R100	1,34 €	1,60 €
11b_024b	43016	Rubber plug for timing control hole, white for BMW R25-R69S and R50/5-R100	1,34 €	1,60 €
11b_025	1250156	Thrust washer pin for crankshaft for BMW R50/5-R100	1,51 €	1,80 €
11b_026a	9908174	Stud bolt cylinder for BMW R50/5-R100	2,61 €	3,10 €
11b_026b	57397	Cylinder bolt, long for BMW R50/5 and up	19,50 €	23,20 €
11b_026b	1335107	Stud bolt cylinder for BMW R45 and R65, long M10x269	20,00 €	23,80 €
11b_026c	1335108	Stud bolt cylinder for BMW R45 and R65, short M10x247	11,43 €	13,60 €
11b_028a	51799	Oil pressure switch for BMW R50/5, R60/5 and R75/5, fine thread	7,73 €	9,20 €
11b_028b	43414	Oil pressure switch for BMW R60/6-R100R until year of manufacture 1995	6,89 €	8,20 €
11b_029	101057	Oil temperatur dipstick for BMW R50/5-R100 and R45/R65 length: 285mm, for deep oil pan, REMANTS	38,91 €	46,30 €
11b_029b	101056	Oil temperatur dipstick for BMW R50/5-R100 and R45/R65 length: 275mm	38,91 €	46,30 €
11b_030	63420	Gasket ring oil dipstick also for oil pump cover for BMW R25/3-R27	0,59 €	0,70 €
11b_032a	19124	Oil drain screw / Oil filler screw for BMW R50/5-R100, M18, hexagon	3,28 €	3,90 €
11b_032b	43117	Oil drain screw, M18, magnetic	7,73 €	9,20 €
11b_032c	912002	Oil temperature relay M14 x 1,5	12,94 €	15,40 €
11b_032c	904029	Oil temperature relay M16 x 1,5	15,04 €	17,90 €
11b_032d	904031	Oil temperature relay M18 x 1,5 VDO	37,14 €	44,20 €
11b_033	63300	Gasket ring, 18x22x1,5 - aluminium	0,25 €	0,30 €
11b_034	62723	Oil pan for BMW R60/6-R100, from year of manufacture 09/1975, medium-sized version in connection with distance piece article nr.: 65590	102,27 €	121,70 €
11b_034a	1337330	Oil pan for BMW R50/5-R100 until year of manufacture 09/1975 and for BMW R65GS-R100GS years of manufacture 1980-1992	102,27 €	121,70 €
11b_034b	64031	Oil pan for BMW R50/5-R100/7 used	25,97 €	30,90 €
11b_034c	1336995	Oil pan for BMW R45-R100 from year of manufacture 09/1981, big version original BMW	100,67 €	119,80 €
11b_034d	1336996	Oil pan deep for BMW /5 and up, 3,5ltr, (sportstyp) Models until 09/1980 main stands must be modified	85,63 €	101,90 €
11b_035	8032	Oil pan gasket for BMW R50/5-R100R, Paper	5,29 €	6,30 €
11b_036	98455	Spring washer B 6,4, DIN137 stainless steel	0,17 €	0,20 €
11b_036	98454	Spring washer B 6, DIN137 zinced	0,17 €	0,20 €
11b_037	98158	Screw M 6 x 20, cylinder-head Allen® key, flat-head	0,50 €	0,60 €
11b_038	98177	Screw M 6 x 60, cylinder-head Allen® key	0,42 €	0,50 €
11b_039a	59469	Generator cover for BMW R50/5-R90S until year of manufacture 09/1975 used - Please specify model	69,24 €	82,40 €
11b_039b	63265	Generator cover for BMW R60/6-R100 years of manufacture 09/1975-09/1979	128,99 €	153,50 €
11b_039c	1335024	Generator cover for BMW R60/7-R100 and R45/R65	154,79 €	184,20 €
11b_040	53415	Ignition point breather hose for BMW R50/5-R100 until year of manufacture 1979	6,89 €	8,20 €
11b_041	98148	Screw M 6 x 35, cylinder-head Allen® key	0,25 €	0,30 €
11b_042	98168	Screw M 6 x 40, cylinder-head Allen® key	0,25 €	0,30 €
11b_043	98410	Washer M 6, DIN125, Form A cinced	0,08 €	0,10 €
11b_046	55011	Radial seal ring, crankshaft front for BMW R50/5-R100	4,71 €	5,60 €
11b_047	112231	Radial seal ring, camshaft for BMW /5 in /6 timing gear cover	3,61 €	4,30 €
11b_047	11223	Radial seal ring, camshaft for BMW R50/5-R90S until year of manufacture 09/1975	3,53 €	4,20 €
11b_047	02197	Radial seal ring, crankshaft front for BMW R50/2-R69S and kick starter for BMW R51/3-R68	3,87 €	4,60 €
11b_047	1262977	Radial seal ring, camshaft for BMW R60/6-R100	3,87 €	4,60 €
11b_048	52311	Nut for timing cover for BMW R50/5-R100, Allen® key	1,93 €	2,30 €
11b_049	65394	Gasket ignition point for BMW R50/5-R100	3,70 €	4,40 €
11b_051	38428	Timing cover gasket for BMW R50/5-R100R	3,03 €	3,60 €
11b_051b	38429	Timing cover gasket, "washer" for BMW R50/5-R100R	0,25 €	0,30 €
11b_053	52095	Grommet wiring harness / engine for BMW R51/3-R69S, horse-shoe-shape R50/5-R90S (2x)	2,94 €	3,50 €
11b_055	1250187	Revolution counter drive from BMW R50/5 and up	34,54 €	41,10 €
11b_057	56860	Radial seal ring, revolution counter shaft for BMW R50/5 and up	3,53 €	4,20 €
11b_058	1259738	Bushing for rpm-counter cable from BMW R50/5 up	8,57 €	10,20 €
11b_059	9911218	Screw for tachometer cable, M 6 x 15	0,42 €	0,50 €
11b_060	1335735	Engine breather tube motor for BMW R45, R65 and R60/7 engine-airfilter until year of manufacture 09/1984	64,37 €	76,60 €
11b_062	1335756	Cover for engine breather for BMW R50/5-R90S, R45, R65 and R65GS	38,07 €	45,30 €
11b_063	1338431	Gasket for engine breather for BMW R50/5-R90S, R45, R65 and R65GS	2,18 €	2,60 €
11b_068	98141	Screw M 5 x 20, hexagon	0,17 €	0,20 €



11b_069	98452	Spring washer B 5, DIN137A zincked	0,08 €	0,10 €
11b_070	00175	Clamp fork boot for BMW R25 and R25/2, bottom (clamp with screw)	1,34 €	1,60 €
11b_071	1255146	Engine breather tube for BMW R50/5-R60/7, R90/6 and R90S	13,70 €	16,30 €
11b_071a	1338215	Engine breather tube for BMW R50/5-R90S with U-arch	7,90 €	9,40 €
11b_073	1338430	Gasket for engine breather for BMW R75/7-R100, RT, rear	1,60 €	1,90 €
11b_077	1338432	Gasket for engine breather for BMW R75/7-R100, RT, front	1,60 €	1,90 €
11b_085	1335734	Engine breather tube for BMW R45, R65 and R60/7 until year of manufacture 09/1980, right side inside air filter	10,34 €	12,30 €
11b_087	1337258	Engine breather tube motor for BMW R45-R100 from year of manufacture 09/80 new housing form	24,79 €	29,50 €
11b_087	1337257	Engine breather hose for BMW R80 from 1985, R45 and R65 from 1978	17,98 €	21,40 €
11b_088	1337108	Engine breather T-Hose for BMW R80/7-R100 from year of manufacture 1976 and BMW R45/R65 from year of manufacture 1978	1,68 €	2,00 €
11b_089a	1337342	Hose clamp engine breather for SLS	1,01 €	1,20 €
11b_089b	9952109	Hose clamp 18-24mm	1,76 €	2,10 €
11b_091	1337492	Engine breather extension for BMW R80-R100 from year of manufacture 1985 and for BMW R45/65 from year of manufacture 1978	1,01 €	1,20 €
11b_095	98175	Screw M 6 x 50, cylinder-head Allen® key	0,25 €	0,30 €
11b_099	1254398	Spring clip for suction hood for BMW R50/5-R100RT until year of manufacture 09/1978	7,14 €	8,50 €
11b_100	63754	Type plate engine for BMW R100/7	37,73 €	44,90 €
11b_100	59366	Type plate engine for BMW R60/6	89,33 €	106,30 €
11b_100	59367	Type plate engine for BMW R75/6	38,91 €	46,30 €
11b_100	59368	Type plate engine for BMW R90/6	37,73 €	44,90 €
11b_100	59369	Type plate engine for BMW R90S	50,67 €	60,30 €
11b_100	57534	Type plate engine for BMW R60/5	21,01 €	25,00 €
11b_100	57533	Type plate engine for BMW R50/5	21,01 €	25,00 €
11b_100	57535	Type plate engine for BMW R75/5	22,10 €	26,30 €
11b_100	64220	Type plate engine for BMW R 60/7	43,19 €	51,40 €
11b_100	1264162	Type plate engine for BMW R100RS, blue	42,44 €	50,50 €
11b_100	1335655	Type plate engine for BMW R100RS, red	42,44 €	50,50 €
11b_100	1335268	Type plate engine for BMW R80/7	38,91 €	46,30 €
11b_100	1259628	Rubber for the red/blue BMW Identification plate on the engine single, means 1 pcs. for 1 side	5,97 €	7,10 €
11b_101b	9796049	Mounting guidelines oilcooler-set in GERMAN	3,27 €	3,50 €
11b_108	1338771	Oil cooler for BMW R100R, R100RT and R100RS	137,82 €	164,00 €
11b_111	1335389	Clamp for oil cooler mount for BMW R100, R100RT and R100RS	3,03 €	3,60 €
11b_112	1335763	Bracket for oilcooler mounting for BMW R100R and R100RS	22,35 €	26,60 €
11b_115a	38511	Oil cooler filter cover for BMW R80GS, R100GS from year of manufacture 1987 and R100R	42,86 €	51,00 €
11b_115b	35376	Oil cooler thermostat with filter cover for BMW R100RT and R100RS original BMW	148,82 €	177,10 €
11b_115b	1335377	Oil cooler filter cover for BMW R100RT and R100RS	64,87 €	77,20 €
11b_119	1335380	O-ring oil cooler / filter head for BMW R100RS and R100RT	2,44 €	2,90 €
11b_123	1335394	Screw for oilcooler breather for BMW R100R, R100RS and R100GS	1,93 €	2,30 €
11b_124a	35376	Oil cooler thermostat with filter cover for BMW R100RT and R100RS original BMW	148,82 €	177,10 €
11b_124b	8530072	Oil cooler thermostat for BMW R100R, R100GS and R80GS Basic	163,36 €	194,40 €
11b_125a	35390	Oil cooler hose thermostat for BMW R100RT and R100RS, long	30,59 €	36,40 €
11b_125b	38718	Oil cooler hose return flow line for BMW R100R	72,27 €	86,00 €
11b_125c	38717	Oil cooler hose flow line for BMW R100R	75,80 €	90,20 €
11b_126	35391	Oil cooler hose thermostat for BMW R100RT and R100RS, short	27,48 €	32,70 €
11b_127	38506	Hollow bolt for oil cooler from year of manufacture 1979	14,96 €	17,80 €



Group 12 Engine electric

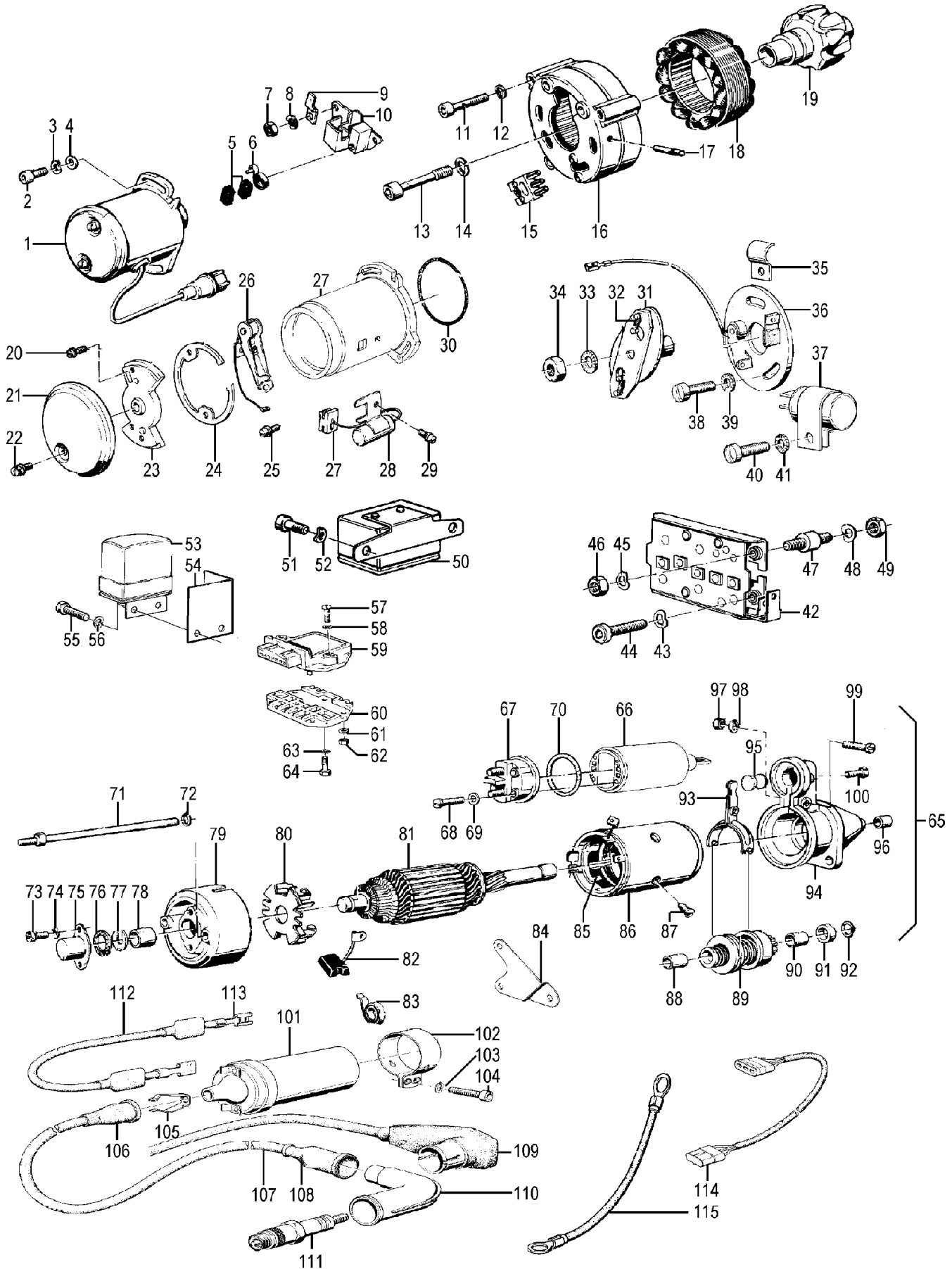

<u>Picture-No.</u>	<u>Article-No.</u>	<u>Description</u>	<u>Net</u>	<u>Gross</u>
12_	98323	Nut M 6 zincked	0,17 €	0,20 €
12_000	1243342	Ignition cable with plug for BMW R60/7-R100 until year of manufacture 09/1984 radio-interference-suppressed	43,19 €	51,40 €



12_000	1243646	Wiring harness, engine for BMW models from year of manufacture 09/1980	31,93 €	38,00 €
12_000	270060	Isolating tube, 6mm price per meter	0,84 €	1,00 €
12_000	98682	Isolating tube (shrink-to-fit), 12mm price per meter	1,26 €	1,50 €
12_000	98681	Isolating tube (shrink-to-fit), 10mm price per meter	1,26 €	1,50 €
12_000	98683	Isolating tube (shrink-to-fit) 3,2mm price per meter	4,79 €	5,70 €
12_000	1350636	Wiring harness, engine for BMW R50/5-R90S	34,54 €	41,10 €
12_000	98679	Isolating tube (shrink-to-fit), 4mm price per meter	0,50 €	0,60 €
12_000	1244177	Cable for ignition coil for BMW R80-R100RT from year of manufacture 09/1980	23,87 €	28,40 €
12_000	104000	Adapter for oil pressure relay in single components	18,24 €	21,70 €
12_000	243224	Charging cable for BMW R45/R65, R60/7-R100R and for BMW R65GS-R100PD, years of manufacture 1980-1995	12,10 €	14,40 €
12_000	98680	Isolating tube (shrink-to-fit), 5mm price per meter	0,67 €	0,80 €
12_000	1357577	Charging cable starter for BMW R60/6-R90S	4,12 €	4,90 €
12_000	1243872	Wiring harness, engine for BMW R60/7-R100, years of manufacture 09/1978-09/1980	62,35 €	74,20 €
12_001a	1243441	Ignition timer R45/65, R80->R100 ->09/80	385,13 €	458,30 €
12_002	98137	Screw M 5 x 16, cylinder-head Allen® key	0,17 €	0,20 €
12_004	98404	Washer M 5, DIN125 stainless steel	0,17 €	0,20 €
12_005	12017	Generator brush for BMW R50/5-R100	3,45 €	4,10 €
12_006	1350786	Generator brush spring for BMW R50/5-R100	2,18 €	2,60 €
12_011	98147	Screw M 5 x 45, cylinder-head Allen® key	0,25 €	0,30 €
12_013a	02348	Generator rotor screw for BMW R50/5-R100	5,04 €	6,00 €
12_013b	06032	Generator rotor remove screw R24-R100, 1948-1996	5,97 €	7,10 €
12_014	98457	Spring washer B 8,4, DIN137B-A2 stainless steel	0,25 €	0,30 €
12_016a	51585	Stator with winding for BMW R50/5-R90S, 12V, 280W diameter 105mm	216,39 €	257,50 €
12_016c	43289	Stator with winding for BMW R60/6-R100, 12V, 280W diameter 107mm	216,39 €	257,50 €
12_017	1350769	Clamping pin generator for BMW models from year of manufacture 09/1969	1,34 €	1,60 €
12_019a	09100	Collector for three-phase current rotor	7,39 €	8,80 €
12_019b	20221	Generator rotor 12 Volt three-phase current	108,32 €	128,90 €
12_026	1014	Ignition point set for BMW R50/5-R100 until year of manufacture 08/1978	11,26 €	13,40 €
12_026	297001	Ignition point set for BMW R45/R65 and R80-R100 years 09/1978-09/1980	15,29 €	18,20 €
12_028	1359890	Condenser for BMW R45-R100, years of manufacture 09/1978-09/1980	13,78 €	16,40 €
12_030	43848	O-ring ignition impulse sending unit for BMW R60/7-R100 and R45/R65	2,86 €	3,40 €
12_031	1357626	Ignition advance unit for BMW R50/5-R100/7 until year of manufacture 08/1978	152,35 €	181,30 €
12_032	4018	Spring for ignition advance unit, years of manufacture 09/1978-09/1980	7,73 €	9,20 €
12_032	1357627	Spring for ignition advance unit, for BMW motorcycles, years of manufacture 09/1974-08/1978	11,01 €	13,10 €
12_032	1356546	Spring for ignition advance unit from year of manufacture 09/1969	2,61 €	3,10 €
12_034b	98325	Nut M 6 stainless steel	0,17 €	0,20 €
12_035	53345	Clamp condenser cable from BMW R50/5 and up, until year of manufacture 09/1978	0,84 €	1,00 €
12_036c	1014003	Contactless ignition system EZA-3, for BMW R50/5-R100 and R45/R65 years of manufacture: 09/1969-09/1980, conversion-kit complete	232,02 €	276,10 €
12_037	1351564	Condenser for BMW R50/5-R100 until year of manufacture 09/1978	5,21 €	6,20 €
12_038	98115	Screw M 4 x 6, cylinder-head, slotted	0,08 €	0,10 €
12_038	98117	Screw M 4 x 10, cylinder-head, slotted	0,25 €	0,30 €
12_039	98450	Spring washer B 4, DIN137 zincked	0,08 €	0,10 €
12_042	4009	Diode plate for 12V three-phase traction drive-generator	71,85 €	85,50 €
12_044	98143	Screw M 5 x 20, cylinder-head Allen® key	0,17 €	0,20 €
12_047	58131	Silent block for diode plate for BMW R50/5 and up	9,50 €	11,30 €
12_048	98452	Spring washer B 5, DIN137A zincked	0,08 €	0,10 €
12_049a	98310	Nut M 5 zincked	0,08 €	0,10 €
12_049b	98311	Nut M 5 stainless steel	0,25 €	0,30 €
12_050a	1389105	Starter relay from year of manufacture 09/1980	17,65 €	21,00 €
12_050b	1350775	Starter relay for BMW R50/5-R75/5	162,10 €	192,90 €
12_050c	1357104	Starter relay for BMW R60/6-R90S	66,81 €	79,50 €
12_050d	1243207	Starter relay for BMW R60/7-R100RT until year of manufacture 09/1984	15,29 €	18,20 €
12_053	44737	Voltage regulator 14,3V for BMW R100RT/R80RT office motorcycle, adjustable! alternating current (AC)	46,81 €	55,70 €
12_053a	2009	Voltage regulator 14,3V for BMW R50/5-R100 alternating current (AC)	34,54 €	41,10 €
12_057	98101	Screw for ignition point cover for BMW R27, M 4 x 25, cylinder-head cross slotted	0,25 €	0,30 €
12_058	98450	Spring washer B 4, DIN137 zincked	0,08 €	0,10 €
12_059	44477	Ignition control for sonic-ignition for BMW models from year of manufacture 09/1980 replacement WITHOUT cooler	65,46 €	77,90 €
12_060	44328	Ignition control for sonic-ignition for BMW models from year of manufacture 09/1980 complete with cooler	105,55 €	125,60 €
12_061	98406	Washer M 4, DIN125 zincked	0,08 €	0,10 €
12_062	98305	Nut M 4 zincked	0,08 €	0,10 €



12_063	98461	Tooth lock washer 4,3mm	0,08 €	0,10 €
12_065B	1244611	Starter repair kit VALEO	9,50 €	11,30 €
12_065b	1244669	Starter with 8 teeth, until year of manufacture 08/1975 DOUBLE POWER, MUCH LESS CHARGE OF BATTERY.	224,96 €	267,70 €
12_065d	1244670	Starter with 9 teeth, from year of manufacture 09/1975	190,34 €	226,50 €
12_066	243142	Magneto switch for BMW models from year of manufacture 09/1974, BOSCH	130,59 €	155,40 €
12_066c	1244607	Magneto switch for Valeo-starter	89,08 €	106,00 €
12_072	98404	Washer M 5, DIN125 stainless steel	0,17 €	0,20 €
12_072	98408	Washer M 5, DIN125, Form A cinced	0,08 €	0,10 €
12_074	98450	Spring washer B 4, DIN137 zincked	0,08 €	0,10 €
12_076	52541	Starter repair kit until year of manufacture 08/1974	36,30 €	43,20 €
12_078	1722916	Starter bushing collector	5,13 €	6,10 €
12_080	1352535	Starter brush holder for R50/5 until year of manufacture 08/1975	31,93 €	38,00 €
12_080a	1244616	Starter brush bracket plate Valeo from year of manufacture 08/1987 until 09/1989	25,88 €	30,80 €
12_080b	1244685	Starter brush bracket plate from year of manufacture 09/1989, VALEO Repair-Kit	21,26 €	25,30 €
12_082	1352536	Generator brush Set for BMW R50/5-R100, Bosch starter	15,29 €	18,20 €
12_082a	1244684	Starter brush set from year of manufacture 09/1989, VALEO	11,18 €	13,30 €
12_083	1352537	Generator brush spring for BMW R50/5-R100, BOSCH starter	2,18 €	2,60 €
12_084	1351590	Starter bracket until year of manufacture 08/1988	3,45 €	4,10 €
12_088	1352533	Starter bushing idle gear BOSCH	6,89 €	8,20 €
12_089	1352532	Starter idle gear Bosch until year of manufacture 08/1974	73,53 €	87,50 €
12_089	1243140	Starter idle gear BOSCH from year of manufacture 09/1975	58,82 €	70,00 €
12_093b	1244609	Starter release lever Valeo	12,94 €	15,40 €
12_096	1352527	Starter bushing pinion until year of manufacture 08/1974	3,45 €	4,10 €
12_098	98457	Spring washer B 8,4, DIN137B-A2 stainless steel	0,25 €	0,30 €
12_101	30025	Ignition coil 6V, for BMW R27 and various other models external, Ø 40mm	24,71 €	29,40 €
12_101	44426	Ignition coil 12V, for BMW R45-R100R years 1980-1995, R65GS-R100PD from 1980 external, 2-spark	171,09 €	203,60 €
12_101	43452	Ignition coil 6V for BMW R50/5 and up, until year of manufacture 09/1980, BOSCH external, Ø 55mm	90,17 €	107,30 €
12_102	43391	Clamp ignition coil for BMW R50/5-R100	4,79 €	5,70 €
12_103	98455	Spring washer B 6,4, DIN137 stainless steel	0,17 €	0,20 €
12_103	98454	Spring washer B 6, DIN137 zincked	0,17 €	0,20 €
12_104	98165	Screw M 6 x 16, cylinder-head Allen® key	0,17 €	0,20 €
12_105	36120	Ignition cable sleeve to solder in	1,34 €	1,60 €
12_105	10272	Ignition cable sleeve, brass, screwable	1,34 €	1,60 €
12_106	36129	Grommet ignition coil for BMW models	7,73 €	9,20 €
12_107	4017	Ignition cable per meter	2,61 €	3,10 €
12_108	8036160	Grommet spark-plug / ignition coil for BMW R24-R27, R51/3-R69S and R50/5-R90S	1,34 €	1,60 €
12_109	43182	Ignition cable with spark plug socket for BMW R50/5-R100	53,03 €	63,10 €
12_109 a	1243253	Ignition cable with plug for BMW R45-R65LS, R65GS-R100PD and R80R-R100R	53,03 €	63,10 €
12_110	5005	Spark plug socket	6,89 €	8,20 €
12_110	5005011	Spark plug socket, NOT fitted with noise suppression	4,29 €	5,10 €
12_111	158158	Spark plug W240T2 for BMW R50-R60/2 long thread	3,28 €	3,90 €
12_111	36168	Spark plug W200T30 for BMW R75/5-R80/7, R90/6, R90S R100 until year of manufacture 1979, R80 (all), R100R and GS	3,28 €	3,90 €
12_111	61280	Spark plug W230T30 for BMW R50/5-R60/7, R90S, R45/R65 and R100 from year of manufacture 1979	3,28 €	3,90 €
12_112	1244176	Wiring harness, Ignition unit for BMW models from year of manufacture 09/1980	21,60 €	25,70 €
12_114	1243178	Wiring harness, generator/diode plate for all BMW models, year of manufacture 09/1969-09/1996	10,17 €	12,10 €
12_114a	1357639	Wiring harness generator / diode plate for BMW R60/6-R100RT	2,18 €	2,60 €
12_115a	1243473	Battery cable Plus for BMW R45/65, R80-R100R and R65GS-R100GS from year of manufacture 09/1983	22,61 €	26,90 €
12_115a	1244475	Battery cable minus for BMW R50/5-R100 until year of manufacture 1995	26,13 €	31,10 €
12_115c	1243874	Battery cable plus from year of manufacture 09/1977 until 08/1983	21,09 €	25,10 €



Group 13a Fuel system

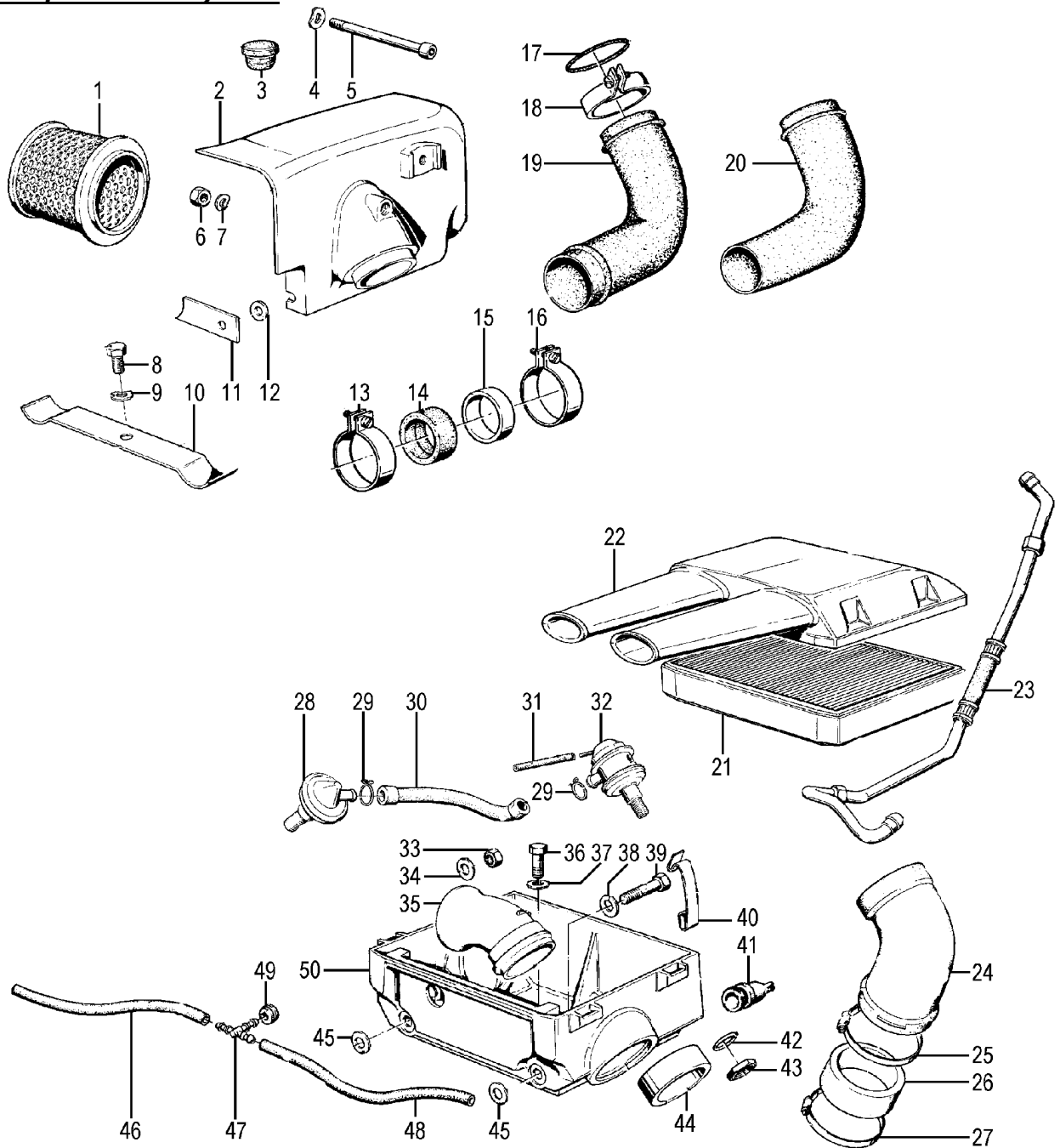

<u>Picture-No.</u>	<u>Article-No.</u>	<u>Description</u>	<u>Net</u>	<u>Gross</u>
13_00	1303017	Fuel hose quick-connector, Ø 7,5mm	7,82 €	9,30 €
13_00	1403017	Fuel hose quick-connector, Ø 9mm NOT for BMW-oldtimer-motorcycle	7,82 €	9,30 €
13_000	7770003	Sticker "Ölfilter-/Luftfilterwechsel" for BMW R50/5 and up 3-colour, Ölfilter-/Luftfilterwechsel = Oilfilter-/Airfilterchange	6,55 €	7,80 €
13a	98352	Nut M 8 zinked	0,17 €	0,20 €
13a	0098352	Nut M 8, wrench size 14 zincked	1,09 €	1,30 €
13a_000	9952119	Clamp airfilter for BMW R50/5, R60/5, R60/6, R60/7 and R60TIC Ø 42-48mm	1,60 €	1,90 €
13a_000	9952121	Clamp airfilter for BMW R50/5-R100 and R65GS-R100GS Ø 47-54mm	2,77 €	3,30 €
13a_001	1048	Air filter insert for BMW R50/5-R100 until year of manufacture 09/1980	9,50 €	11,30 €
13a_003	80222	Rubber plug for choke mount at the gearbox for BMW R50/5, R60/5 and R60/6 and steering head for BMW R45/R65, R60/6-R100R	1,26 €	1,50 €
13a_005	54042	Screw for air intake housing for BMW R50/5-R100 and R45/R65	4,37 €	5,20 €
13a_006	13432	Nut M8 for airfilter from BMW R50/5	0,42 €	0,50 €
13a_008	098201	Screw M 8 x 20, hexagon stainless steel	0,34 €	0,40 €
13a_008	98201	Screw for chain tensioner, simplex for BMW R45/R65 and R60/7-R100, M 8 x 20, hexagon and holding screw for exhaust pipe for BMW R50-R69S	0,17 €	0,20 €
13a_009	98457	Spring washer B 8,4, DIN137B-A2 stainless steel	0,25 €	0,30 €
13a_010	1251169	Clamp spring, airfilter (round version) for BMW models, years of manufacture 09/1969-09/1980	8,57 €	10,20 €
13a_011	1335977	Spring shackle air filter housing from BMW R50/5 and up	4,03 €	4,80 €



13a_012	3060174	Spacer washer airfilter housing for BMW R50/5-R100RT until year of manufacture 09/1980	1,93 €	2,30 €
13a_014	1338360	Air tube rubber 54mm for BMW R100RS, RT from year of manufacture 1987 until 1995 Head/Carburettor	8,32 €	9,90 €
13a_014	1254200	Air tube rubber for BMW R50/5-R60/7 26mm, carburettor/intake tube	8,82 €	10,50 €
13a_014	1259820	Air tube rubber for BMW R90S Carburettor rubber sleeve for air pipe	4,37 €	5,20 €
13a_015	1257395	Air tube rubber for BMW R75/5-/7, R90/6, R90S, R80/7, R100-/7 carburettor/intake tube	5,13 €	6,10 €
13a_015	1260342	Reinforcement ring for air tube R90S REMAINDER	16,39 €	19,50 €
13a_017	57763	O-ring air tube for BMW R50/5-R100RT until year of manufacture 1981	1,93 €	2,30 €
13a_018	61026	Clamp fork boot for BMW R50/5-R100/7 (clamp with screw)	1,34 €	1,60 €
13a_018	9061026	Clamp air tube for BMW R50/5, R60/5, R60/6 and R60/7 (clamp with screw)	1,34 €	1,60 €
13a_018	9161026	Clamp air tube rubber for BMW R75/5, R75/6 and R90/6 (clamp with screw)	1,34 €	1,60 €
13a_019	1262787	Intake pipe for BMW R80 and R100, (with 40mm-Carburettor), left side from year of manufacture 09/1978	21,18 €	25,20 €
13a_019	1262788	Intake pipe for BMW R80, R100, (with 40mm-Carburettor), right side from year of manufacture 09/1978	21,09 €	25,10 €
13a_019	1258060	Intake pipe for BMW R75/5-R100/7 and R90S, right side for 32mm carburettor + Dellorto	21,09 €	25,10 €
13a_019	1258059	Intake pipe for BMW R75/5-R100/7 and R90S, left side for 32mm carburettor + Dellorto	21,09 €	25,10 €
13a_020	1251612	Intake pipe for BMW R50/5-R60/7, right side	16,30 €	19,40 €
13a_020	1251611	Intake pipe for BMW R50/5-R60/7, left side	18,66 €	22,20 €
13a_021	9048	Air filter insert for BMW R45/R65-R100 until year of manufacture 09/1980, square	20,34 €	24,20 €
13a_022	1337675	Air filter housing for BMW R65-R100 from year of manufacture 09/1982, top	36,30 €	43,20 €
13a_024	1335111	Intake pipe for BMW R45 and R65 until year of manufacture 09/1980, left side	33,53 €	39,90 €
13a_024	1335112	Intake pipe for BMW R45 and R65 until year of manufacture 09/1980, right side	38,82 €	46,20 €
13a_024	1335700	Intake pipe for BMW R80-R100R/MYS and R65GS-R80PD, left and right side from year of manufacture 09/1980 (for flat-airfilter)	21,68 €	25,80 €
13a_026	1338362	Air tube rubber for 94/40mm Carburettor at head from year of manufacture 09/1986 and BMW R100GS, PD, R100R	6,64 €	7,90 €
13a_026	1264392	Air tube rubber for intake tube/air-filter housing, years of manufacture 09/1975-08/1986 and for BMW R45 and R65, Head/carburator R100 with 94/40 carburator from year 09/1978	5,71 €	6,80 €
13a_033b	98353	Nut M 8 stainless steel	0,42 €	0,50 €
13a_035	1337233	Intake pipe for BMW R65-R100, inner, left side for flat-airfilter	15,88 €	18,90 €
13a_035	1337078	Intake pipe for BMW R65-R100, inner, right side for flat-airfilter	15,88 €	18,90 €
13a_037	98416	Washer M 8, DIN125/A2 stainless steel	0,17 €	0,20 €
13a_038	98416	Washer M 8, DIN125/A2 stainless steel	0,17 €	0,20 €
13a_040	37105	Air filter retaining clip for BMW R80/R100 from year of manufacture 1981 and for BMW R45 and R65	4,54 €	5,40 €
13a_041	1337162	Rubber valve for square air filter	11,18 €	13,30 €
13a_042	63132	Gasket ring M16, e.g. oil drain screw	0,25 €	0,30 €
13a_044	1337229	Air tube stud for BMW R65-R100 from year of manufacture 1979 until 1995 air-filter housing, flat-airfilter	10,92 €	13,00 €
13a_045	98416	Washer M 8, DIN125/A2 stainless steel	0,17 €	0,20 €
13a_046	1337512	Engine breather tube for BMW R45-R100 from year of manufacture 09/1980, right side inside air filter	8,40 €	10,00 €
13a_048	1337511	Engine breather tube for BMW R45-R100 from year of manufacture 09/1980, left side inside air filter	6,47 €	7,70 €



Group 13b BING carburetor R50/5-R60/7

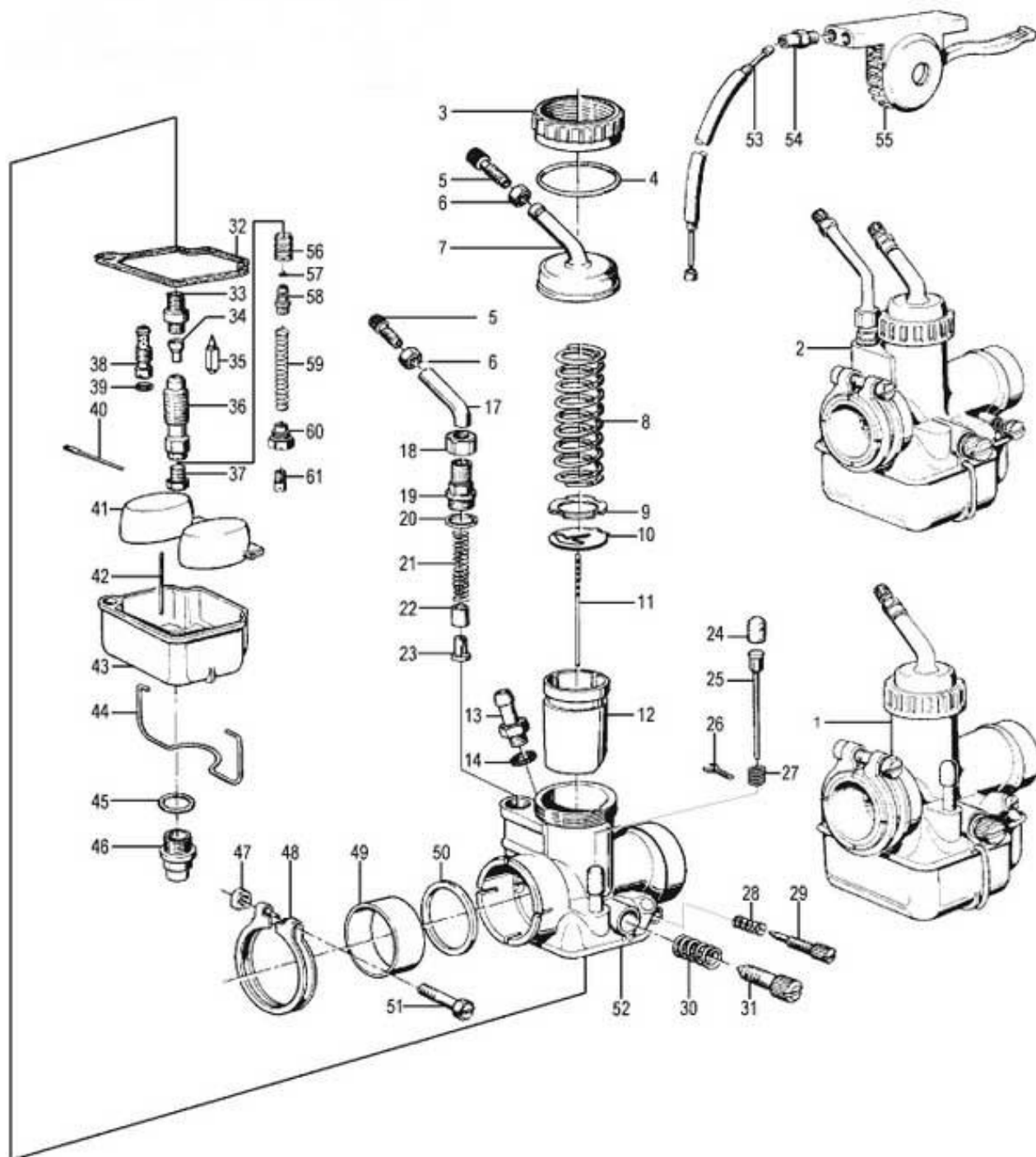

<u>Picture-No.</u>	<u>Article-No.</u>	<u>Description</u>	<u>Net</u>	<u>Gross</u>
13b	3017	Fuel hose, oldtime-look, per meter	4,20 €	5,00 €
13b	3017713	Fuel hose, rubber-look, per meter	3,28 €	3,90 €
13b_000	39001	Gasket set for carburettor for BMW R50/5-60/7 and R26, R27 Special	6,97 €	8,30 €
13b_003	14049	Carburettor slide cover nut for BMW R50/2-R69S and R50/5-R60/7 big version	34,12 €	40,60 €
13b_004	54932	O-ring slide top for BMW R50/5, R60/5, R60/6 and R60/7	0,84 €	1,00 €
13b_005	42112	Grommet for throttle cable on carburettor, small, traditionally for BMW R24-R27 (can be used on all other models)	1,34 €	1,60 €
13b_005	39178	Throttle adjusting screw M 6, long for BMW R24-R25/3, R50-R69S and R50/5-R90/6	2,18 €	2,60 €
13b_005	42111	Grommet for throttle cable on carburettor, large	1,60 €	1,90 €
13b_006	39182	Nut M 6 for throttle adjusting screw	0,50 €	0,60 €
13b_007c	54933	Carburettor slide cover replacement for BMW R50/5, R60/5, R75/5, R60TIC and R60/7 left/right, with screwed tube	30,34 €	36,10 €
13b_008	54929	Carburettor slide spring for BMW R50/5, R60/5, R60TIC and R60/7	2,02 €	2,40 €
13b_009	59276	Washer carburettor plate for BMW R50/5, R60/5, R60/6 and R60/7	0,92 €	1,10 €



13b_010	1254927	Jet needle retaining plate for BMW R50/5-R60/7	0,84 €	1,00 €
13b_011	1254926	Jet needle for BMW R50/5-R60/7	5,38 €	6,40 €
13b_012	54925	Carburettor slide for BMW R50/5-R60/7	20,42 €	24,30 €
13b_013	1254919	Hose stud carburettor for BMW R50/5, R60/5, R60/6, R60TIC and R60/7	3,45 €	4,10 €
13b_014	1254920	Gasket ring hose connector for BMW R50/5-R60/7	0,42 €	0,50 €
13b_017	1261351	Choke cable elbow pipe für BMW R60/6 and R60/7	8,40 €	10,00 €
13b_017b	61350	Carburettor slide cover tube for BMW R51/3-R69S and R50/5-R60/7	10,84 €	12,90 €
13b_019	1261348	Cap nut choke cable tube for BMW R60/6, R60/7 and R60T	2,02 €	2,40 €
13b_019b	1261347	Screw socket elbow pipe for BMW R60/6 and R60/7	1,76 €	2,10 €
13b_020	40060	Gasket ring fuel cock/tank for BMW R25/3-R69S and R50/5-R100 for all fuel cocks with connection M20x1	0,42 €	0,50 €
13b_021	61345	Start piston spring carburettor for BMW R60/6 and R60/7	0,67 €	0,80 €
13b_022	1335688	Bushing starter piston for BMW R60/6 and R60/7	1,60 €	1,90 €
13b_023	35687	Starter piston for carburettor for BMW R60/6 and R60/7	4,79 €	5,70 €
13b_025	54911	Carburettor tickler for BMW R50/5, R60/5 and R60/6 until year of manufacture 1974	5,80 €	6,90 €
13b_026	39165	Pin for carburettor tickler for BMW R25-R69S	0,50 €	0,60 €
13b_027	54912	Spring for carburettor tickler for BMW R50/5, R60/5 and R60/6 until year of manufacture 1974	0,59 €	0,70 €
13b_028	1254918	Spring for idle mixture screw for BMW R50/5-R60/7	0,59 €	0,70 €
13b_029	1254917	Mixture regulating screw for BMW R50/5, R60/5, R60/6 and R60/7	3,70 €	4,40 €
13b_030	1254922	Spring slide adjusting screw for BMW R50/5, R60/5, R75/5, R60TIC and R60/7	1,01 €	1,20 €
13b_031	54921	Slide adjusting screw for BMW R50/5, R60/5, R60/6 and R60/7	3,61 €	4,30 €
13b_032	1254924	Gasket float chamber for BMW R50/5-R60/7	2,18 €	2,60 €
13b_033	60973	Mixing chamber insert (atomizer) for BMW R50/5-R100	5,63 €	6,70 €
13b_034a	54909	Needle jet #2.64 for BMW R50/5-R60/7 and R45/R65	7,14 €	8,50 €
13b_034b	54910	Needle jet #2.66 for BMW R50/5, R60/5, R60/6 and R60/7	7,14 €	8,50 €
13b_034c	54914	Needle jet #2.68 for BMW R50/5, R60/5, R60/6 and R60/7	8,15 €	9,70 €
13b_034d	54919	Needle jet #2.70 for BMW R50/5, R60/5, R60/6 and R60/7	7,14 €	8,50 €
13b_034e	54907	Needle jet #2.73 for BMW R50/5, R60/5, R60/6 and R60/7	7,14 €	8,50 €
13b_035a	25049	Float needle for BMW R50/5-R90/6, R60/7 and R75/7, "old" (square) for BING-carburettor 53 and 64-0	13,19 €	15,70 €
13b_035b	35318	Float needle for BMW R45/R65, R80/7-R100RS, "new" (three-edged) for BING-carburettor 64-2, -3 and 94	11,60 €	13,80 €
13b_036	1255816	Accelerator pump complete for BMW R50/5-R60/7 for BING	75,63 €	90,00 €
13b_037a	39140	Main jet, slotted, # 135	4,29 €	5,10 €
13b_037b	39141	Main jet, slotted, # 140	4,29 €	5,10 €
13b_039	54735	O-ring idle jet for BMW R50/5-R100 and mixture regulating screw R75/5-R100	1,43 €	1,70 €
13b_040	54768	Float axle for BMW R50/5-R100RS	0,92 €	1,10 €
13b_041	54766	Float divided for BMW R50/5-R100	18,15 €	21,60 €
13b_043	54923	Float chamber for BMW R50/5, R60/5 and R60/6 until year of manufacture 08/1974 for carburettor WITHOUT accelerating pump	14,87 €	17,70 €
13b_043	1261343	Float chamber for BMW R60/6, R60TIC and R60/7 from year of manufacture 08/1974 for carburettor WITH accelerating pump	25,55 €	30,40 €
13b_045	42122	Gasket ring for BMW R24-R27 Cover nut for BMW R50/5-R60/7, 53er carburator	0,42 €	0,50 €
13b_046	55817	Locking screw for float chamber for BMW R50/5, R60/5 and R60/6	3,11 €	3,70 €
13b_047	39284	Nut for carburettor clamp for BMW R26, R27 and R50/5-R75/5	0,50 €	0,60 €
13b_048	1254913	Gripper clamp, carburettor for BMW R50/5, R60/5, R60/6 and R60/7	5,97 €	7,10 €
13b_049	1255975	Isolating bushing carburettor for BMW R50/5, R60/5 and R60/7	9,50 €	11,30 €
13b_050	1255974	Insolating washer carburettor for BMW R50/5, R60/5, R60/6 and R60/7	0,92 €	1,10 €
13b_051	36968	Screw for gripper clamp carburettor for BMW R26, R27, R50/5, R60/5, R60/6 and R60/7	2,61 €	3,10 €
13b_053a	1260365	Choke cable for BMW R50/5, R60/5/6/7, years of manufacture 1969-09/1984, left side	15,97 €	19,00 €
13b_053b	1260366	Choke cable for BMW R50/5, R60/5/6/7, years of manufacture 1969-09/1984, right side	15,97 €	19,00 €
13b_053c	1260644	Choke cable for R90S fits for left or right side, 1 piece	17,23 €	20,50 €
13b_054	1260368	Choke cable nipple at adjusting lever for BMW R50/5, R60/5, R60/6, R60/7 and R90S	3,03 €	3,60 €
13b_055	1260191	Choke lever from BMW R75/5 on gearbox	46,55 €	55,40 €
13b_056	00054	Piston injection pump for BMW R50/5, R60/5, R60/6 and R60/7	4,29 €	5,10 €
13b_057	00050	Valve accelerating pump for BMW R27, R50/5, R60/5, R60/6 and R60/7	0,50 €	0,60 €
13b_058	00052	Threaded connection accelerator pump for BMW R50/5-R60/7	2,44 €	2,90 €
13b_059	00051	Spring for acceleration pump for BMW R27 and R50/5-R60/7	0,76 €	0,90 €
13b_060	00053	Jet holder locking screw for BMW R50/5-R60/7 accelerator pump	3,03 €	3,60 €
13b_060	1254731	Jet holder for BMW R50/5 and R60/5, ../53/..BING carburettor REMNANTS	6,89 €	8,20 €
13b_060a	42122	Gasket ring for BMW R24-R27 Cover nut for BMW R50/5-R60/7, 53er carburator	0,42 €	0,50 €
13b_061a	39131	Main jet, slotted, # 90	4,29 €	5,10 €
13b_061b	39132	Main jet, slotted, # 95	4,29 €	5,10 €



13b_061c	39133	Main jet, slotted, # 100	4,29 €	5,10 €
13b_061d	39134	Main jet, slotted, # 105	4,29 €	5,10 €
13b_061e	39135	Main jet, slotted, # 110	4,29 €	5,10 €
13b_061f	39136	Main jet, slotted, # 115	4,29 €	5,10 €
13b_061g	39137	Main jet, slotted, # 120	4,29 €	5,10 €
13b_061h	39138	Main jet, slotted, # 125	4,29 €	5,10 €
13b_061i	39139	Main jet, slotted, # 130	4,29 €	5,10 €
13b_061j	39140	Main jet, slotted, # 135	4,29 €	5,10 €
13b_061k	39141	Main jet, slotted, # 140	4,29 €	5,10 €
13b_061l	39142	Main jet, slotted, # 145	4,29 €	5,10 €
13b_061m	39143	Main jet, slotted, # 150	4,29 €	5,10 €
13b_061n	39144	Main jet, slotted, # 155	4,29 €	5,10 €
13b_061o	39145	Main jet, slotted, # 160	4,29 €	5,10 €



Group 13c Bing carburetor R75/-R100

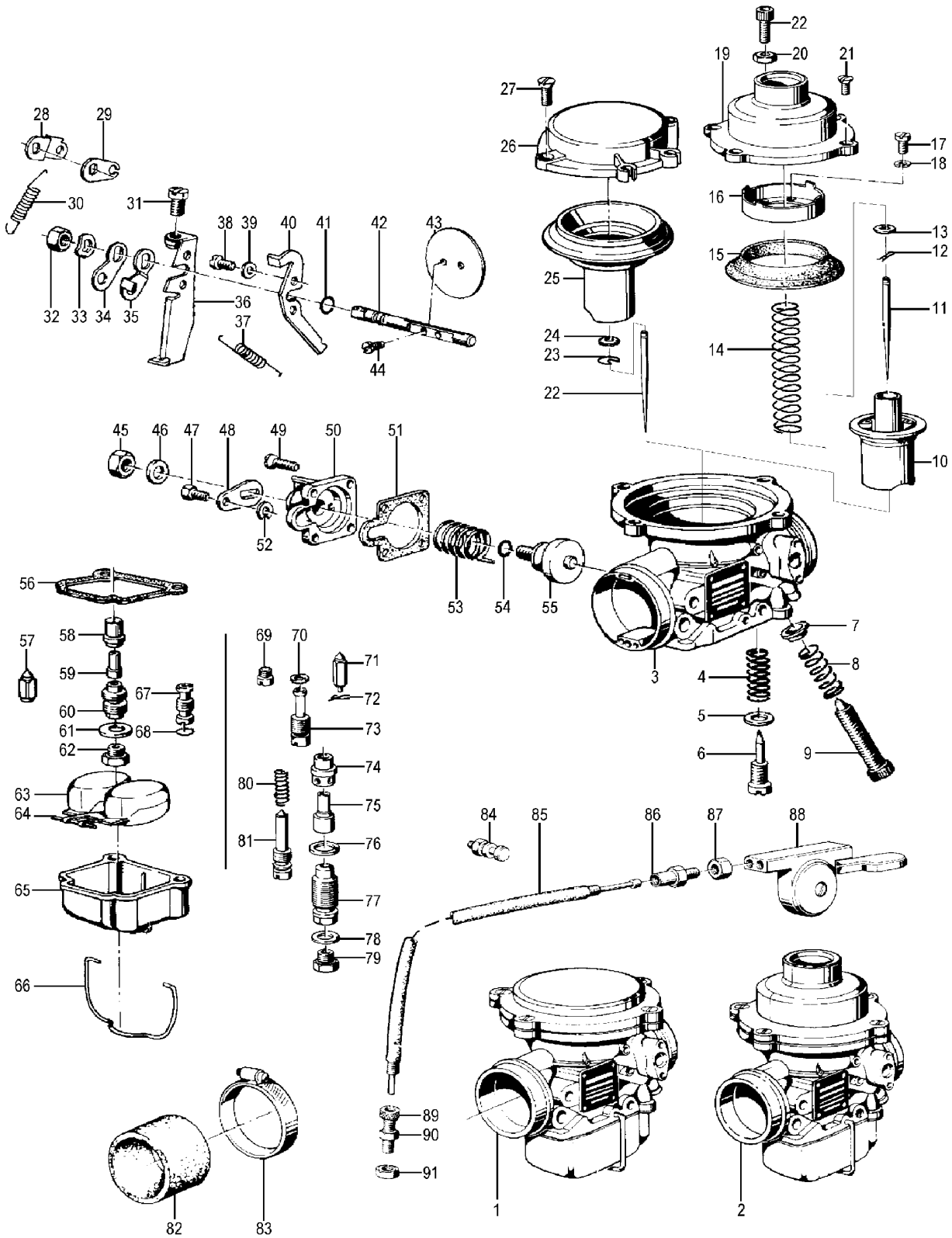

<u>Picture-No.</u>	<u>Article-No.</u>	<u>Description</u>	<u>Net</u>	<u>Gross</u>
13c	3017	Fuel hose, oldtime-look, per meter	4,20 €	5,00 €
13c	3017713	Fuel hose, rubber-look, per meter	3,28 €	3,90 €
13c_000	1338241	Jet needle screwing for BMW R45/R65, R65GS-R100GS und R80-R100R from year of manufacture 09/1982	3,03 €	3,60 €
13c_000	39002	Gasket set for Carburettor for BMW R75/5-R100 (for 2 Carburettors)	26,13 €	31,10 €
13c_000	59870	Gasket ring for vacuum screw for BMW R75/5-R100	0,34 €	0,40 €
13c_001	37433	Carburettor for BMW R100RT/T/CS/RS from year of manufacture 1981, left side 94/40/111	424,12 €	504,70 €
13c_001	37434	Carburettor for BMW R100RT/T/CS/RS from year of manufacture 1981, right side 94/40/112	424,12 €	504,70 €



13c_002	38365	Carburettor for BMW R100GS and R100R from year of manufacture 1990, left side 94/40/123	424,12 €	504,70 €
13c_002	38366	Carburettor for BMW R100GS and R100R from year of manufacture 1990, right side 94/40/124	424,12 €	504,70 €
13c_002	37815	Carburettor for BMW R80-R80GS, left side 64/32/353	461,34 €	549,00 €
13c_002	53858	Carburettor for BMW R75/5, R75/6 and R75/7 until year of manufacture 1981, left side 64/32/313	689,75 €	820,80 €
13c_002	53857	Carburettor for BMW R75/5, R75/6 and R75/7 until year of manufacture 1981, right side 64/32/314	689,75 €	820,80 €
13c_002	37816	Carburettor for BMW R80-R80GS, right side 64/32/354A	461,34 €	549,00 €
13c_002	1265613	Carburettor for BMW R100RS/RT/S until year of manufacture 1981, left side 94/40/105	424,12 €	504,70 €
13c_002	1265614	Carburettor for BMW R100RS/RT/S until year of manufacture 1981, right side 94/40/106	424,12 €	504,70 €
13c_004	1254736	Spring for idle mixture screw for BMW R75/5	0,84 €	1,00 €
13c_006	1335302	Mixture regulating screw for BMW R75/5-R100, R45/R65 and R65GS-R100GS	4,79 €	5,70 €
13c_008	54751	Spring slide adjusting screw for BMW R75/5-R100	2,02 €	2,40 €
13c_009	1254750	Adjusting screw for butterfly valve for BMW R75/5-R100	2,86 €	3,40 €
13c_011a	1255840	Jet needle for BMW R75/5-R80/7, R80 until year of manufacture 05/1983 R45 and R65 until year of manufacture 09/1982 (.../64/...-carburetor)	6,05 €	7,20 €
13c_011b	1335321	Jet needle for BMW R100/7, RS, R80 (94er)	4,79 €	5,70 €
13c_011b	1337692	Jet needle for BMW R80 and R100 until year of manufacture 09/1980 and for BMW R65GS-R80GS until year of manufacture 09/1982 (.../64/...-carburetor)	5,63 €	6,70 €
13c_011d	1338522	Jet needle for BMW R100 and R100GS from year of manufacture 1988	3,70 €	4,40 €
13c_011e	1311999	Jet needle for BMW R100 special for 64/32-carburettor from year of manufacture 09/1982 > 1,5l lower fuel to 100km !	3,28 €	3,90 €
13c_012	1254771	Jet needle retaining spring for BMW R75/5-R100	2,61 €	3,10 €
13c_013	1254773	Jet needle notched ring for BMW R75/5-R100	0,59 €	0,70 €
13c_014	35324	Carburettor slide spring for BMW R45/R65 and R80/7-R100RS for BING-carburettor 64-3 and 94	7,73 €	9,20 €
13c_014b	1338134	Carburettor slide spring for BMW R65-R100 from year of manufacture 1985	6,47 €	7,70 €
13c_015	54774	Diaphragm for BING-carburettor 64/32/.... also fits on "flat-top" carburetors	16,13 €	19,20 €
13c_015	35322	Diaphragm for BING-carburettor 94/40/...	30,76 €	36,60 €
13c_016	1337358	Diaphragm holding ring for BMW R65-R100 from year of manufacture 1979, BING-carburettor 64/32/....	12,52 €	14,90 €
13c_016	35323	Diaphragm holding ring for BMW R100S, RS, RT, GS, R, BING-carburettor 94/40/....	4,29 €	5,10 €
13c_016	54775	Diaphragm holding ring for BMW R75/5-R100/7 until year of manufacture 1979, BING-carburettor 64/32/.	3,70 €	4,40 €
13c_017	37359	Screw for butterfly and membrane mount for BMW R75/5-R100	0,50 €	0,60 €
13c_019	1254769	Carburettor slide with diaphragm and cover for BMW R75/5 for BING-carburettor 64/32/3+4, 64/32/9+10	164,87 €	196,20 €
13c_021	37361	Carburettor slide cover screw for BMW R75/5-R100 stainless steel, cross slot	0,67 €	0,80 €
13c_021b	37362	Carburettor slide cover screw for BMW R75/5-R100RS slotted screw	0,50 €	0,60 €
13c_022	1230840	Throttle adjusting screw M 6 from BMW R65 and up, with nut	8,40 €	10,00 €
13c_023	1338242	Jet needle clamp ring for BMW models from year of manufacture 09/1982	0,50 €	0,60 €
13c_025	36881	Carburettor slide with diaphragm for BMW R45/N for BING-carburettor 64/26/201-202	69,16 €	82,30 €
13c_025	36880	Carburettor slide with diaphragm for BMW R90/6 and R100/7 for BING-carburettor 64/32/219-220	103,03 €	122,60 €
13c_025	1336878	Carburettor slide with diaphragm for BMW R45 and R45T	98,57 €	117,30 €
13c_027	37362	Carburettor slide cover screw for BMW R75/5-R100RS slotted screw	0,50 €	0,60 €
13c_028	1337369	Choke cable lever at carburettor from BMW R80/7 up	3,61 €	4,30 €
13c_029	1337368	Choke lever Carburettor from BMW R60/7 and up	1,51 €	1,80 €
13c_030	1337409	Choke lever extension spring for BMW R100R, S, RT, T, CS, RS	2,35 €	2,80 €
13c_030	1335312	Choke lever extension spring R75/5-R100 BING 32/...	3,87 €	4,60 €
13c_031	1335311	Adjusting screw for butterfly valve for BMW R80/7-R100	1,51 €	1,80 €
13c_032	54760	Nut M 8 for butterfly-axle, BING 64/...	0,84 €	1,00 €
13c_034	1335608	Throttle lever carburettor, 64/32/..., outer, until year of manufacture 09/1978	1,43 €	1,70 €
13c_034	1335310	Throttle lever carburettor, 94/40/..., outer, from year of manufacture 09/1978	1,34 €	1,60 €
13c_034A	1254747	Throttle lever carburettor for BMW R75/5-/7, R100/7 and R100RT, from year of manufacture 09/1978	1,76 €	2,10 €
13c_035a	1335609	Throttle lever carburettor, 64/32/..., inner left side, until year of manufacture 09/1995	2,77 €	3,30 €
13c_035a	1335308	Throttle lever carburettor, 94/40/..., left side, from year of manufacture 09/1978	2,18 €	2,60 €
13c_035b	1335607	Throttle lever carburettor, 64/32/..., inner right side, until year of manufacture 09/1995	1,51 €	1,80 €
13c_035b	1335309	Throttle lever carburettor, 94/40/..., right side, from year of manufacture 09/1978	2,02 €	2,40 €
13c_036	1335305	Throttle control bracket, right side BING, 64/... and 94/...	13,78 €	16,40 €
13c_036	1335304	Throttle control bracket, left side BING, 64/... and 94/...	13,78 €	16,40 €
13c_037a	1254908	Carburettor throttle butterfly control spring for BMW R75/5-R100/7	2,44 €	2,90 €
13c_037b	1335512	Carburettor throttle butterfly control spring for BMW R100S, RS, RT, R	2,86 €	3,40 €
13c_037c	1335606	Carburettor throttle butterfly control spring for BMW R80/7-R100 and R45, R65	2,61 €	3,10 €



13c_041	54739	O-ring throttle shaft for BMW R75/5-R100	1,76 €	2,10 €
13c_042a	1335745	Throttle valve shaft for BMW R100 and R80 from year of manufacture 09/1978 for 94/40/.. type	13,36 €	15,90 €
13c_042b	1336585	Throttle valve shaft for BMW R75/5-R100 and R45, R65 for 64/32/.. type	10,25 €	12,20 €
13c_043a	1335605	Carburettor throttle butterfly for BMW R75/5-R100RT until year of manufacture 09/1978	5,13 €	6,10 €
13c_043b	1335746	Carburettor throttle butterfly for BMW R100 from year of manufacture 09/1978	11,76 €	14,00 €
13c_044	1254738	Mounting-screw for butterfly valve for BMW R45, R65 and R75/5-R100 until year of manufacture 1994 BING 64-2	0,92 €	1,10 €
13c_047	1254757	Nipple adaptor for choke cable (Carburettor) for BMW R75/5 until year of manufacture 12/1970	1,93 €	2,30 €
13c_048b	1335315	Choke lever carburettor for BMW R75/5-R100 until year of manufacture 08/1980	11,26 €	13,40 €
13c_049	37367	Screw choke housing for BMW R75/5-R100	0,59 €	0,70 €
13c_050	1257815	Starter device 64/32/... 01/71 >, r/h R75/5/6/7, R90/6, R45/65, R80	28,49 €	33,90 €
13c_050	1257816	Starter device 64/32/... 01/71 >, l/h R75/5/6/7, R90/6, R45/65, R80	28,49 €	33,90 €
13c_051	1256353	Gasket choke housing for BMW R75/5-R100	1,09 €	1,30 €
13c_052	1254758	Security clip for choke cable-nipple adaptor for BMW R50/5, R60/5 and R75/5	0,34 €	0,40 €
13c_053	1255533	Pressure spring piston starter device for BMW R75/5-R100, right side	0,59 €	0,70 €
13c_053a	1255534	Pressure spring piston starter device for BMW R75/5-R100, left side	0,59 €	0,70 €
13c_054	57819	O-ring starter axle for BMW R75/5-R100	1,85 €	2,20 €
13c_056	1254764	Gasket float chamber for BMW R45, R65 and R75/5-R100	3,87 €	4,60 €
13c_057	25049	Float needle for BMW R50/5-R90/6, R60/7 and R75/7, "old" (square) for BING-carburettor 53 and 64-0	13,19 €	15,70 €
13c_057	35318	Float needle for BMW R45/R65, R80/7-R100RS, "new" (three-edged) for BING-carburettor 64-2, -3 and 94	11,60 €	13,80 €
13c_058b	60973	Mixing chamber insert (atomizer) for BMW R50/5-R100	5,63 €	6,70 €
13c_059a	35744	Needle jet # 2.64 for BMW R75/5-R100	6,72 €	8,00 €
13c_059e	54729	Needle jet #2.73 for BMW R75/5-R100	6,72 €	8,00 €
13c_059f	28028	Needle jet #2.62 for BMW R75/5-R100	6,72 €	8,00 €
13c_059g	45196	Needle jet #2.60 for BMW R75/5-R100	6,72 €	8,00 €
13c_061	54732	Washer main jet diaphragm carburettor	0,59 €	0,70 €
13c_062a	39240	Main jet, hexagon, # 135	5,21 €	6,20 €
13c_062b	39242	Main jet, hexagon, # 145	5,21 €	6,20 €
13c_062c	39243	Main jet, hexagon, # 150	5,21 €	6,20 €
13c_062d	39245	Main jet, hexagon, # 160	5,55 €	6,60 €
13c_062e	39246	Main jet, hexagon, # 165	5,21 €	6,20 €
13c_062f	39247	Main jet, hexagon, # 170	5,21 €	6,20 €
13c_063	54766	Float divided for BMW R50/5-R100	18,15 €	21,60 €
13c_064	54768	Float axle for BMW R50/5-R100RS	0,92 €	1,10 €
13c_065a	54763	Float chamber for BMW R45/R65, R75/5-R100, R65GS, R80G/S, R80GS, left side	25,29 €	30,10 €
13c_065b	54762	Float chamber for BMW R45/R65, R75/5-R100, R65GS, R80G/S, R80GS, right side	32,86 €	39,10 €
13c_065c	35317	Float chamber for BMW R80 from year of manufacture 09/1984, right side also for BMW R100 until year of manufacture 09/1984	31,76 €	37,80 €
13c_065d	35316	Float chamber for BMW R80 from year of manufacture 09/1984, left side also for BMW R100 until year of manufacture 09/1984	33,78 €	40,20 €
13c_065e	1338839	Float chamber for BMW R80GS-R100PD, years 1988-1995, left side also for BMW R80R-R100R years 1991-1995	34,71 €	41,30 €
13c_065f	1338840	Float chamber for BMW R80GS-R100PD, years 1988-1995, right side also for BMW R80R-R100R years 1991-1995	28,49 €	33,90 €
13c_066	1254765	Locking clip float bowl for BMW R50/5-R100R	3,87 €	4,60 €
13c_067a	61704	Idle jet #40 for BMW R75/5 until year of manufacture 1979 up to vehicle identification number 2977320	11,26 €	13,40 €
13c_067b	35602	Idle jet #50 for BMW R75/5 until year of manufacture 1979 up to vehicle identification number 2977320	11,26 €	13,40 €
13c_067b	54734	Idle jet #45 for BMW R75/5 until year of manufacture 1979 up to vehicle identification number 2977320	12,86 €	15,30 €
13c_068	54735	O-ring idle jet for BMW R50/5-R100 and mixture regulating screw R75/5-R100	1,43 €	1,70 €
13c_069	39123	Choke jet for BMW R75/5, R75/6 and R90/6, #66, slot	4,29 €	5,10 €
13c_069a	39129	Choke jet for BMW R75/5-R90/6, #80, slotted	4,29 €	5,10 €
13c_071	35318	Float needle for BMW R45/R65, R80/7-R100RS, "new" (three-edged) for BING-carburettor 64-2, -3 and 94	11,60 €	13,80 €
13c_072	35320	Float needle spring for BMW R45/R65 and R75/7-R100RS	0,76 €	0,90 €
13c_073	55557	Idle jet #40 for BMW-motorcycles until year of manufacture 1979 from vehicle identification number 2977321 - please see details for motorcycles types!!!	8,82 €	10,50 €
13c_073a	54913	Idle jet #30 for BMW-motorcycles until year of manufacture 1979 from vehicle identification number 2977321 - please see details for motorcycles types!!!	14,45 €	17,20 €
13c_073b	54915	Idle jet #35 for BMW-motorcycles until year of manufacture 1979 from vehicle identification number 2977321 - please see details for motorcycles types!!!	16,72 €	19,90 €
13c_073c	54916	Idle jet #40 for BMW-motorcycles from year of manufacture 1979	12,35 €	14,70 €
13c_073d	36924	Idle jet #45 for BMW-motorcycles up from year of manufacture 1979	11,09 €	13,20 €
13c_073e	36949	Idle jet #50 for BMW-motorcycles from year of manufacture 1979	10,92 €	13,00 €



13c_073f	36950	Idle jet #55 for BMW-motorcycles until year of manufacture 1979 from vehicle identification number 2977321 - please see details for motorcycles types!!!	11,09 €	13,20 €
13c_074	60973	Mixing chamber insert (atomizer) for BMW R50/5-R100	5,63 €	6,70 €
13c_075	45196	Needle jet #2.60 for BMW R75/5-R100	6,72 €	8,00 €
13c_075	54729	Needle jet #2.73 for BMW R75/5-R100	6,72 €	8,00 €
13c_075	35744	Needle jet # 2.64 for BMW R75/5-R100	6,72 €	8,00 €
13c_075	28028	Needle jet #2.62 for BMW R75/5-R100	6,72 €	8,00 €
13c_075a	57810	Needle jet #2.70 for BMW R75/5-R100	6,72 €	8,00 €
13c_075b	60971	Needle jet #2.68 for BMW R75/5-R100	6,89 €	8,20 €
13c_075c	61702	Needle jet #2.66 for BMW R75/5-R100	7,14 €	8,50 €
13c_076	57812	O-ring carburettor jet for BMW R75/5-R100RS	1,18 €	1,40 €
13c_077	1335600	Jet holder for BMW R75/5-R100 and R65GS/R80GS, ../64/..BING carburettor	9,58 €	11,40 €
13c_077	1335298	Jet holder for BMW R80, R100 with ../94/..BING carburettor	6,39 €	7,60 €
13c_078	54732	Washer main jet diaphragm carburettor	0,59 €	0,70 €
13c_079	39249	Main jet, hexagon, # 180	5,21 €	6,20 €
13c_079	39250	Main jet, hexagon, # 185	5,21 €	6,20 €
13c_079	39252	Main jet, hexagon, # 190	5,21 €	6,20 €
13c_079	13176	Main jet, hexagon, #176	5,21 €	6,20 €
13c_079	13178	Main jet, hexagon, # 178	5,21 €	6,20 €
13c_079	39232	Main jet, hexagon, # 95	5,21 €	6,20 €
13c_079	39233	Main jet, hexagon, # 100	5,21 €	6,20 €
13c_079	39234	Main jet, hexagon, # 105	5,21 €	6,20 €
13c_079	39235	Main jet, hexagon, #110	5,21 €	6,20 €
13c_079	39236	Main jet, hexagon, # 115	5,55 €	6,60 €
13c_079	39237	Main jet, hexagon, # 120	5,21 €	6,20 €
13c_079	39238	Main jet, hexagon, # 125	5,21 €	6,20 €
13c_079	39239	Main jet, hexagon, # 130	5,21 €	6,20 €
13c_079	39240	Main jet, hexagon, # 135	5,21 €	6,20 €
13c_079	39241	Main jet, hexagon, # 140	5,21 €	6,20 €
13c_079	39242	Main jet, hexagon, # 145	5,21 €	6,20 €
13c_079	39243	Main jet, hexagon, # 150	5,21 €	6,20 €
13c_079	39244	Main jet, hexagon, # 155	5,21 €	6,20 €
13c_079	39245	Main jet, hexagon, # 160	5,55 €	6,60 €
13c_079	39248	Main jet, hexagon, # 175	5,21 €	6,20 €
13c_079	39247	Main jet, hexagon, # 170	5,21 €	6,20 €
13c_079	39246	Main jet, hexagon, # 165	5,21 €	6,20 €
13c_079	39231	Main jet, hexagon, # 90	5,21 €	6,20 €
13c_080	1254736	Spring for idle mixture screw for BMW R75/5	0,84 €	1,00 €
13c_081	1335302	Mixture regulating screw for BMW R75/5-R100, R45/R65 and R65GS-R100GS	4,79 €	5,70 €
13c_082	1254654	Air tube rubber for BMW BMW R45, R65 and R75/5-R100/7, 64/32/... (head/carb.), R80/7 from year of manufacture 1981 (carb./intake tube)	4,37 €	5,20 €
13c_083	61026	Clamp fork boot for BMW R50/5-R100/7 (clamp with screw)	1,34 €	1,60 €
13c_083	9061026	Clamp air tube for BMW R50/5, R60/5, R60/6 and R60/7 (clamp with screw)	1,34 €	1,60 €
13c_083	9161026	Clamp air tube rubber for BMW R75/5, R75/6 and R90/6 (clamp with screw)	1,34 €	1,60 €
13c_084	9057338	Clamp screw, choke cable for BMW R75/5-R100 until year of manufacture 08/1980 and for BMW R45 and R65 until year of manufacture 08/1980	5,80 €	6,90 €
13c_085a	1252826	Choke cable for BMW R75/5, until year of manufacture 01/1971, flexibel, left side (up to FIN 2977320) only with carburator 64/32/3	7,73 €	9,20 €
13c_085b	1252827	Choke cable for BMW R75/5, until year of manufacture 01/1971, flexibel, right side (up to FIN 2977320) only with carburator 64/32/4	7,73 €	9,20 €
13c_085c	1255976	Choke cable for BMW R75/5, from year of manufacture 01/1971, stiff, left side and for BMW R90/6, R45 und R65, R80, R100 until year of manufacture 09/1980	7,39 €	8,80 €
13c_085d	1255977	Choke cable for BMW R75/5, from year of manufacture 01/1971, stiff, right side and for BMW R90/6, R45 und R65, R80, R100 until year of manufacture 09/1980	8,07 €	9,60 €
13c_086	1256019	Choke cable nipple at adjusting lever for R75/5-R100 until year of manufacture 08/1980	3,11 €	3,70 €
13c_087	21038	Nut M 5 for throttle adjusting screw	0,25 €	0,30 €
13c_088	1260191	Choke lever from BMW R75/5 on gearbox	46,55 €	55,40 €
13c_089	1256295	Adjusting screw choke cable carburettor for BMW R75/5-R100 until year of manufacture 08/1980 for stiff choke cable	10,59 €	12,60 €
13c_091	39182	Nut M 6 for throttle adjusting screw	0,50 €	0,60 €
13c_999	59869	Screw vacuum pressure connector for BMW R75/5-R100	0,50 €	0,60 €



Group 13d Dellorto carburetor R90S

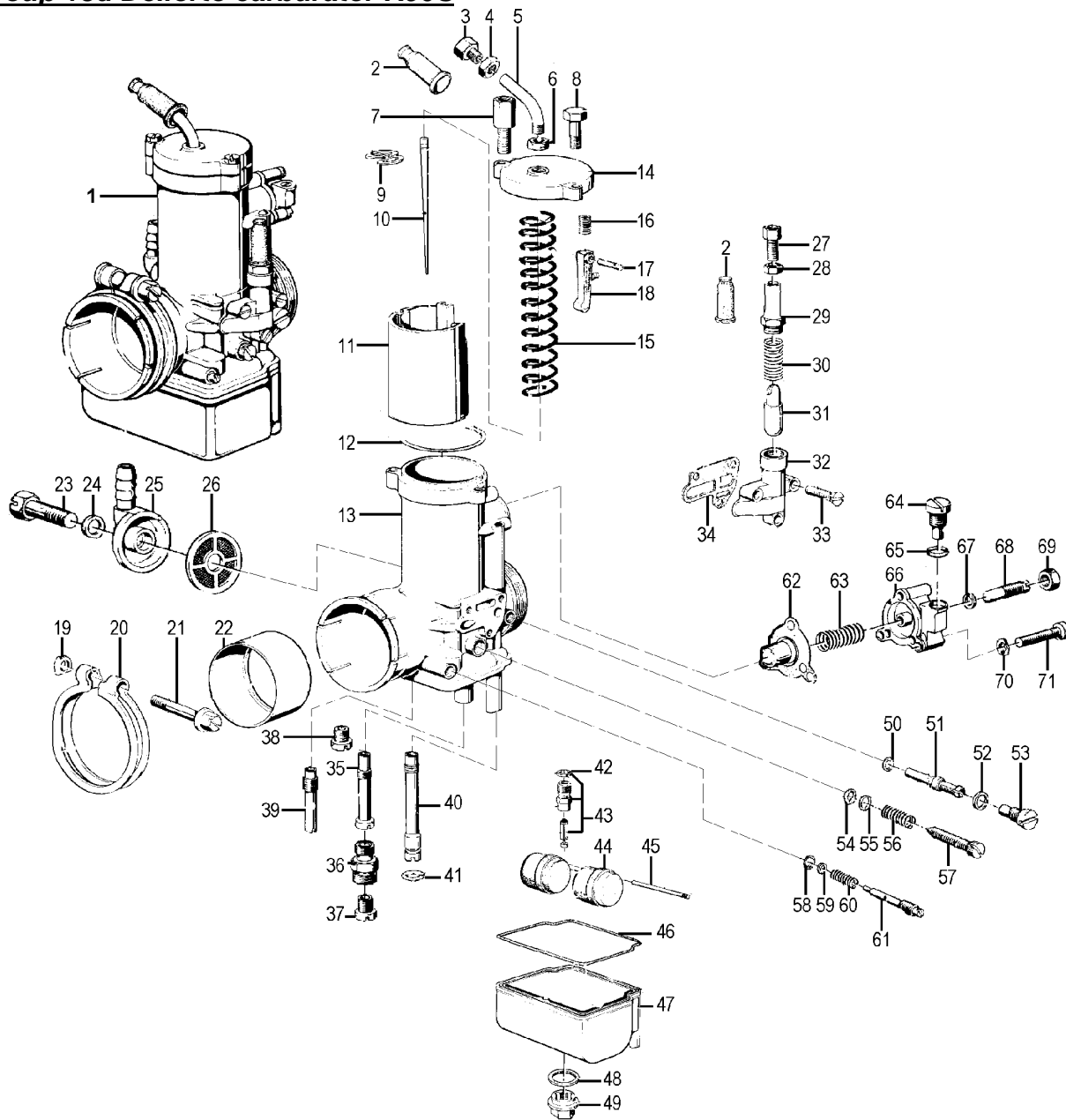

<u>Picture-No.</u>	<u>Article-No.</u>	<u>Description</u>	<u>Net</u>	<u>Gross</u>
13d_001	62399	"Carburettor for BMW R90S ""Dellorto"", right side"	254,62 €	303,00 €
13d_001	62398	"Carburettor for BMW R90S ""Dellorto"", left side"	254,62 €	303,00 €
13d_002	1260874	Grommet for throttle cable on carburettor for BMW R90S "Dellorto" also grommet for choke cable for BMW R90S "Dellorto"	1,09 €	1,30 €
13d_007	1264281	Throttle adjusting screw for BMW R90S "Dellorto" only for the old version !	5,21 €	6,20 €
13d_008	1260845	Carburettor slide cover screw for BMW R90S "Dellorto"	1,18 €	1,40 €
13d_009	1260880	Jet needle retaining spring for BMW R90S "Dellorto"	0,84 €	1,00 €
13d_010	1260882	Jet needle for BMW R90S "Dellorto"	13,95 €	16,60 €
13d_011	260881	"Carburettor slide for BMW R90S ""Dellorto"""	50,67 €	60,30 €
13d_012	260883	O-ring slide top for BMW R90S "Dellorto"	2,18 €	2,60 €
13d_014	260846	Carburettor slide cover for BMW R90S "Dellorto"	4,79 €	5,70 €
13d_015	260879	Carburettor slide spring for BMW R90S "Dellorto"	1,93 €	2,30 €
13d_016	1260848	Spring for fuel pump for BMW R90S "Dellorto"	0,50 €	0,60 €
13d_017	1260847	Bolt fuel-pump for BMW R90S "Dellorto"	1,68 €	2,00 €
13d_018	1260849	Fuel pump lever for BMW R90S "Dellorto"	1,60 €	1,90 €
13d_021	36968	Screw for gripper clamp carburettor for BMW R26, R27, R50/5, R60/5, R60/6 and R60/7	2,61 €	3,10 €
13d_022	1260885	Isolating bushing carburettor for BMW R90S	3,95 €	4,70 €
13d_024	1260890	Gasket ring fuel entry for BMW R90S "Dellorto"	1,76 €	2,10 €
13d_025	1260889	Cover hose connection for BMW R90S "Dellorto"	2,77 €	3,30 €
13d_026	260888	Sieve tube adapter for BMW R90S "Dellorto"	2,77 €	3,30 €
13d_027	1260875	Adjusting screw choke cable for BMW R90S "Dellorto"	4,29 €	5,10 €



13d_028	1260876	Adjusting screw nut choke cable for BMW R90S "Dellorto"	0,76 €	0,90 €
13d_030	1261353	Spring for choke for BMW R90S "Dellorto"	1,01 €	1,20 €
13d_031	261354	"Valve choke for BMW R90S ""Dellorto"""	2,18 €	2,60 €
13d_034	1261357	Gasket valve base for BMW R90S "Dellorto"	1,93 €	2,30 €
13d_035	1260871	"Mixing chamber for BMW R90S ""Dellorto"""	9,75 €	11,60 €
13d_036	1260872	Jet holder for BMW R90S "Dellorto"	7,48 €	8,90 €
13d_037	1260873	Main jet, for BMW R90S "Dellorto", # 155	2,35 €	2,80 €
13d_038	260893	Idle jet for BMW R90S "Dellorto"	14,96 €	17,80 €
13d_039	260892	"Valve (float chamber) for BMW R90S ""Dellorto"""	9,75 €	11,60 €
13d_040	1261358	Injection valve for BMW R90S "Dellorto"	3,95 €	4,70 €
13d_041	260861	O-ring power enrichment valve for BMW R90S "Dellorto" and injection valve	1,09 €	1,30 €
13d_043	260895	Float needle set for BMW R90S "Dellorto"	14,87 €	17,70 €
13d_044	260896	Float for BMW R90S "Dellorto"	14,62 €	17,40 €
13d_046	260898	O-ring float chamber for BMW R90S "Dellorto"	2,77 €	3,30 €
13d_047	260899	Float chamber for BMW R90S "Dellorto"	28,32 €	33,70 €
13d_048	1260900	Gasket ring for float chamber screw for BMW R90S "Dellorto" old version	2,61 €	3,10 €
13d_049	1260901	"Lock screw float chamber for BMW R90S ""Dellorto"" old version, wrench size 14 - 4 bore holes	12,10 €	14,40 €
13d_049	260901	"Lock screw float chamber for BMW R90S ""Dellorto"" new version	10,59 €	12,60 €
13d_052	1260855	Gasket ring jet holder for BMW R90S "Dellorto"	0,34 €	0,40 €
13d_055	1260858	Washer slide adjusting screw for BMW R90S "Dellorto"	1,01 €	1,20 €
13d_056	1260857	"Spring for adjusting-screw for BMW R90S ""Dellorto"""	1,93 €	2,30 €
13d_057	1260856	Slide adjusting screw for BMW R90S "Dellorto"	2,35 €	2,80 €
13d_058	260850	O-ring carburettor regulating screw for BMW R90S "Dellorto"	1,93 €	2,30 €
13d_059	1260851	Washer mixture regulating screw carburettor for BMW R90S "Dellorto"	0,84 €	1,00 €
13d_060	1260852	Spring for idle mixture screw for BMW R90S "Dellorto"	0,67 €	0,80 €
13d_061	1260853	Mixture regulating screw for BMW R90S	3,70 €	4,40 €
13d_062	260870	Diaphragm carburettor for BMW R90S "Dellorto"	36,47 €	43,40 €
13d_063	1260869	Spring for pump cover for BMW R90S "Dellorto"	0,84 €	1,00 €
13d_064	260860	Pump valve for BMW R90S "Dellorto"	7,82 €	9,30 €
13d_065	260859	O-ring pump valve for BMW R90S "Dellorto" and regulation screw bottom	1,68 €	2,00 €
13d_067	260863	O-ring adjusting screw for BMW R90S "Dellorto"	1,51 €	1,80 €
13d_999	39006	Gasket set for Carburettor for BMW R90S "Dellorto"	10,34 €	12,30 €



Group 16 Fuel tank

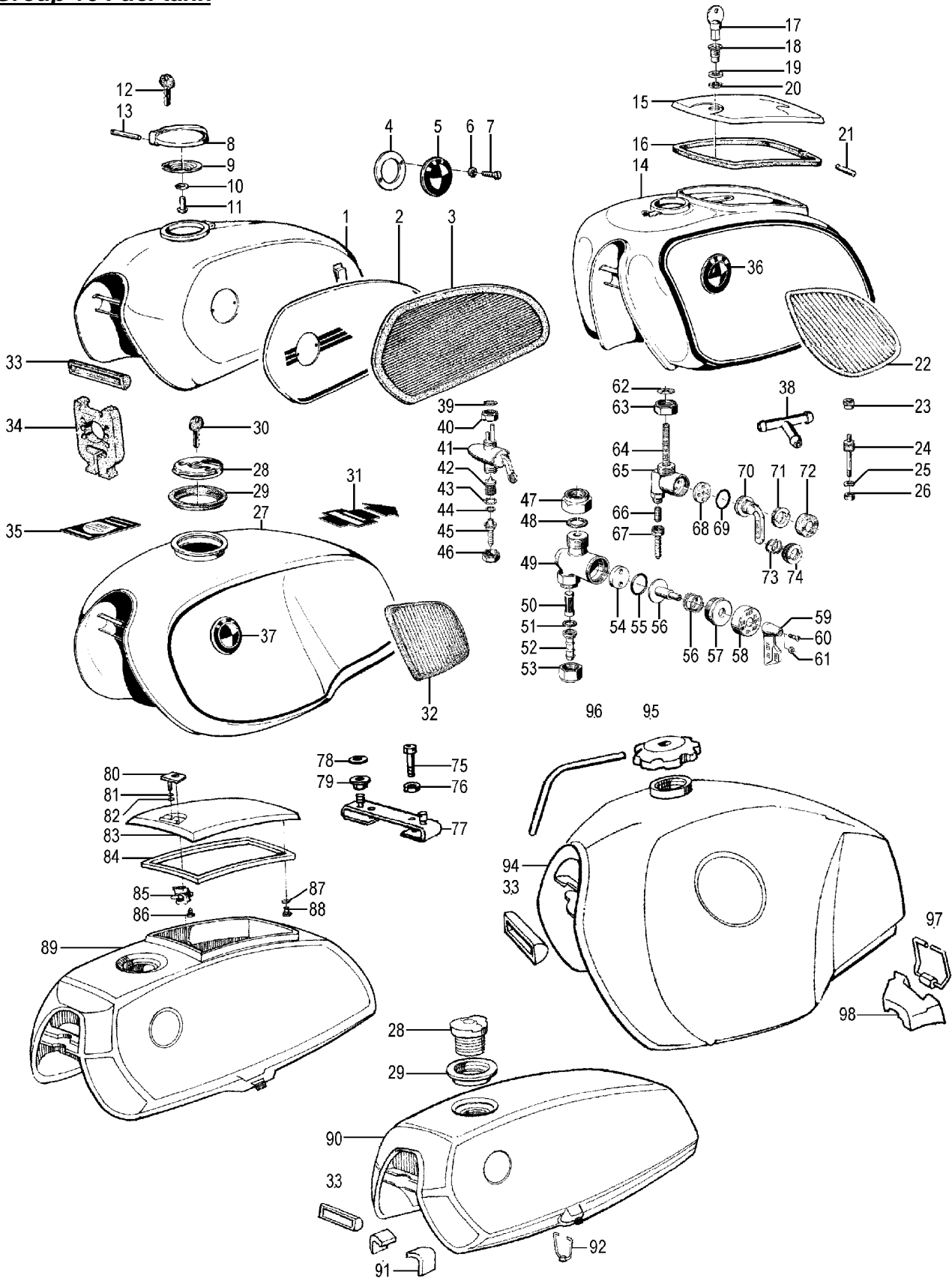

<u>Picture-No.</u>	<u>Article-No.</u>	<u>Description</u>	<u>Net</u>	<u>Gross</u>
16_00	1303017	Fuel hose quick-connector, Ø 7,5mm	7,82 €	9,30 €
16_00	1403017	Fuel hose quick-connector, Ø 9mm NOT for BMW-oldtimer-motorcycle	7,82 €	9,30 €
16_000	2307037	Sticker for tank, left side for BMW R80GS "800", black	13,87 €	16,50 €
16_000	99201	Fuel hose clamp with contact jaw omega style	1,60 €	1,90 €
16_000	99993	Fuel-filter with paper inlay, stick-in-hose, universal, transparent	2,44 €	2,90 €
16_000	99200	Fuel hose clamp with snail thread	1,09 €	1,30 €
16_000	2323569	"Sticker for BMW "BOXER" left side" silver	34,29 €	40,80 €



16_000	2323570	"Sticker for BMW ""BOXER"" right side" silver	34,29 €	40,80 €
16_001	32001	Fuel tank for BMW R50/5, R60/5 and R75/5, new painted, black, 17 liters (refurbished) for chrome-panels	579,83 €	690,00 €
16_002	1231866	Chrom-panel for fuel tank "toaster" (17L), left side for BMW R50/5, R60/5 and R75/5 until year of manufacture 09/1972	122,94 €	146,30 €
16_002a	1231867	Chrom-panel for fuel tank "toaster" (17L), right side for BMW R50/5, R60/5 and R75/5 until year of manufacture 09/1972	122,94 €	146,30 €
16_003a	1232235	Knee pad for BMW R50/5-R90/6, on 17L-tank, from year of manufacture 09/1972, only left side (single = 1 pc.)	25,13 €	29,90 €
16_003b	1232236	Knee pad for BMW R50/5-R90/6, on 17L-tank, from year of manufacture 09/1972, only right side (single = 1 pc.)	25,13 €	29,90 €
16_004	1230506	Emblem rubber for tank for BMW R50/5-R75/5	4,87 €	5,80 €
16_005	30769	Emblem for BMW R50/5, R60/5 and R75/5, tank, enamel, for screwing original BMW	44,54 €	53,00 €
16_007	9901703	Emblem screw for BMW R50/5, R60/5, R75/5 and R90S stainless steel	0,42 €	0,50 €
16_007	1038	Emblem screw for BMW R25/2-R69S stainless steel	0,42 €	0,50 €
16_007a	9910381	Emblem screw for BMW R24-R69S, cross-slot stainless steel	0,50 €	0,60 €
16_008	32348	Fuel tank cap for BMW R50/5-R90S, with lock and gasket aluminum polished	77,82 €	92,60 €
16_008a	1232348	Fuel tank cap for BMW R50/5-R90S, WITHOUT lock with gasket	43,19 €	51,40 €
16_009	30603	Gasket for fuel tank cap from BMW R50/5-R90S	20,92 €	24,90 €
16_010	36413	Shim for fuel tank cap for BMW R50/5-R90S	1,18 €	1,40 €
16_011	44651	Groove pin for fuel tank cap for BMW R50/5-R90S	1,43 €	1,70 €
16_012	9062680	Key base, standard, solid for BMW models until year of manufacture 1980	4,96 €	5,90 €
16_012	53659	Key base, foldable	20,17 €	24,00 €
16_012	1233554	Key base, standard, solid for BMW models from year of manufacture 1980	14,20 €	16,90 €
16_013	30883	Fuel tank cap axle for BMW R50/5-R90S	4,29 €	5,10 €
16_014	33864	Fuel tank for BMW R50/5-R90/6, new painted, 24 liters good condition – PLEASE CALL OR MAIL US BEFORE YOU ORDER!!!	578,99 €	689,00 €
16_014b	33862	Fuel tank for BMW R50/5-R90/6, primed, 22 liters, with tool box original BMW, NEW	735,63 €	875,40 €
16_015	31298	Tool box cover for BMW R25/2, R26, R27, R51/3-R68, R65 and R50/5-R100 police model, opens lengthways	42,27 €	50,30 €
16_016	80188	Gasket tool box for BMW R24-R25/2, R26, R27 and R51/3-R68, tank above	5,21 €	6,20 €
16_017	41016	Key for tool box, square-end for BMW R24-R25/2, R26, R27 and R51/2-R68 also battery cover key for BMW R26 and R27	3,95 €	4,70 €
16_018	80165	Screw for tool box, square-end for BMW R24-R25/2, R26, R27 and R51/2-R68 single	2,86 €	3,40 €
16_018	0180167	Screw Set for tool box, square-end for BMW R24-R25/2, R26, R27 and R51/2-R68 complete with mounting parts	3,87 €	4,60 €
16_020	63108	O-ring tool box lock screw for BMW R24, R25, R25/2, R26, R27 and R51/2-R68	0,42 €	0,50 €
16_021	10140	Split pin for tool box cover for BMW R50/5-R100, ONLY for police version	1,51 €	1,80 €
16_022a	1230048	Knee pad for BMW R50/5-R90/6, on 24L-tank, only left side (single = 1 pc.)	22,94 €	27,30 €
16_022b	1230049	Knee pad for BMW R50/5-R90/6 on 24L-tank, only right side (single = 1 pc.)	22,94 €	27,30 €
16_023	33457	Fuel tank holding nut / batterie holding nut for BMW R50/5-R100 until year of manufacture 09/1984 plastic	4,12 €	4,90 €
16_024	30045	Fuel tank holder rubber for BMW R50/5-R100, rear	6,05 €	7,20 €
16_027	52284	Fuel tank for BMW R60/7-R100RT, new painted (refurbished)	770,34 €	916,70 €
16_027a	52283	Fuel tank for BMW R60/7-R100RT, primed also as alternative for R90S, original BMW, NEW	662,10 €	787,90 €
16_028	1453910	Gasket for fuel tank cap for BMW R65GS, R80GS Basic und R80G/S from year of manufacture 1980-1992	8,82 €	10,50 €
16_029	53148	Gasket for fuel tank cap from BMW R60/7->	7,31 €	8,70 €
16_029	07360	Ring (outer) for fuel tank cap for BMW R90S and up	7,31 €	8,70 €
16_032a	1234048	Knee pad for BMW R90S and R60/7-R100, only right side (single = 1 pc.)	35,46 €	42,20 €
16_032b	1234047	Knee pad for BMW R90Sm and R60/7-R100, only left side (single = 1 pc.)	35,46 €	42,20 €
16_033	36124	Fuel tank holder rubber for BMW R45/R65, R65GS-R100GS, R80R and R100R, front	4,54 €	5,40 €
16_033a	230031	Fuel tank holder rubber for BMW R50/5-R100 until year of manufacture 1984, front	5,13 €	6,10 €
16_034	1230030	Tank support rubber for BMW models, from year of manufacture 09/1969	5,80 €	6,90 €
16_035	1453617	Sticker "Sicherer mit Helm" for fuel tank for BMW R45/R65, R90S and R60/7-R100 Sicherer mit Helm = Safe with helmet	4,12 €	4,90 €
16_036b	37927	Emblem for BMW R90S, tank, enamel, to glue-on - fits also for BMW R60/6-R100, original BMW	42,94 €	51,10 €
16_036b	7686746	Emblem for BMW R60/6-R100RT until 1987 and for seat bench R90S, R100S, CS, RS, RT until 09/1984 Ø=70mm, Alu, stick on label, original BMW	18,91 €	22,50 €
16_036c	2325183	Emblem for BMW R80GS, R100GS from year of manufacture 09/1987 and R80R, R100R aluminum, stick-on label, original BMW	20,25 €	24,10 €
16_038	1336900	Fuel hose connector, T-piece	5,21 €	6,20 €
16_039	4084110	Gasket ring fuel cock Everbest-shape for BMW R25/3-R27 and R50/5-R75/5 fits also fuelcock for R24 with external thread	0,67 €	0,80 €
16_043	4084109	Gasket ring for original "old" fuel cock Everbest A18 x 21	0,92 €	1,10 €
16_048	40060	Gasket ring fuel cock/tank for BMW R25/3-R69S and R50/5-R100 for all fuel cocks with connection M20x1	0,42 €	0,50 €



16_049	84008	Pet cock for R25/3-R27, R50/5-R75/5, R60/6-R90S, with 1 outflow/leaving, "Everbest" ORIGINAL-FORM "EVERBEST"	43,19 €	51,40 €
16_055	1234869	O-ring pet cock (new shape) for BMW R50/5-R100	2,35 €	2,80 €
16_058	1233367	Pet cock cover from BMW R50/5 black	2,02 €	2,40 €
16_062	63077	Gasket ring fuel cock for small threads, M14 Frankfurter Armaturenwerke	0,67 €	0,80 €
16_063	84120	Pet cock nut for R25/3-R69S M16x1 left-hand thread, M20x1 right-hand thread	2,86 €	3,40 €
16_064	2307112	Pet cock sieve in tank for pet cock "new form" inner Ø: 10mm, outer Ø: 13mm, length: 115mm	4,37 €	5,20 €
16_065	80008	Pet cock for BMW R25/3-R27 and R50/5-R75/5, with 1 outflow/leaving	27,73 €	33,00 €
16_067	33366	Pet cock fuel line adaptor (single) with fine sieve, plastic	1,93 €	2,30 €
16_068	1238924	Pet cock Viton-sealing-washer for Karcoma pet cocks "new form"	3,03 €	3,60 €
16_069	1234869	O-ring pet cock (new shape) for BMW R50/5-R100	2,35 €	2,80 €
16_072	08008	Pet cock for BMW R25/3-R27 and R50/5-R100 WITH drain-pool	40,34 €	48,00 €
16_072a	1240400	Pet cock new shape for BMW R50/5-R90S, 1 outlet downwards	40,59 €	48,30 €
16_072b	1233557	Pet cock new shape, with 2 outflow/leaving	45,46 €	54,10 €
16_072c	2307113	Pet cock new form for BMW R60/7-R100, left side with socketsieve	48,15 €	57,30 €
16_072d	2307114	Pet cock new form for BMW R60/7-R100, right side with socketsieve	48,15 €	57,30 €
16_078	34336	Steering damper and tank-circlip	1,93 €	2,30 €
16_079	1453144	Fuel tank holder rubber for BMW R65-R100 from year of manufacture 1985, rear	1,60 €	1,90 €
16_084	80188	Gasket tool box for BMW R24-R25/2, R26, R27 and R51/3-R68, tank above	5,21 €	6,20 €
16_090	38728	Fuel tank for BMW R45 and R65, white painted original BMW, NEW	579,33 €	689,40 €
16_091	37552	Fuel tank holder for BMW R45/R65, R65GD, R80G/S, R80ST, R80GS Basic, rear, left side	18,49 €	22,00 €
16_091	37553	Fuel tank holder for BMW R45/R65, R65GD, R80G/S, R80ST, R80GS Basic, rear, right side	18,49 €	22,00 €
16_092	1240159	Fuel tank holder, rear for BMW R45/R65, R65GS, R80GS and R80ST years 1980-1992 small tank	14,62 €	17,40 €
16_092	2307004	Fuel tank holder, rear for BMW R65GS-R80GS Basic, R80R und R100R until year of manufacture 1995 big tank	31,93 €	38,00 €
16_095	1453817	Fuel tank cap for BMW R65GS-R100GS and R80GS Basic years of manufacture 09/1980-1996 lockable	61,85 €	73,60 €
16_095	1453910	Gasket for fuel tank cap for BMW R65GS, R80GS Basic und R80G/S from year of manufacture 1980-1992	8,82 €	10,50 €
16_096	2307010	Fuel tank overflow tube for BMW R80R-R100R, R65GS-R100GS and for BMW R60/7-R100, R45/R65 (must be shortend!)	16,72 €	19,90 €
16_097	1240159	Fuel tank holder, rear for BMW R45/R65, R65GS, R80GS and R80ST years 1980-1992 small tank	14,62 €	17,40 €
16_097	2307004	Fuel tank holder, rear for BMW R65GS-R80GS Basic, R80R und R100R until year of manufacture 1995 big tank	31,93 €	38,00 €
16_098	2307014	Fuel tank distance rubber for BMW R65GS-R100R, rear	20,67 €	24,60 €
16_999	1455167	Grommet cable holder for BMW R80GS, R100GS, R80R and R100R from year of manufacture 09/1990	0,50 €	0,60 €
16_999	2307010	Fuel tank overflow tube for BMW R80R-R100R, R65GS-R100GS and for BMW R60/7-R100, R45/R65 (must be shortend!)	16,72 €	19,90 €
16_999	1234819	Gasket tool box for BMW R60/7-R80 and R100 years of manufacture 1974-1984, tank ONLY for police model tanks	3,70 €	4,40 €



Group 18 Exhaust system

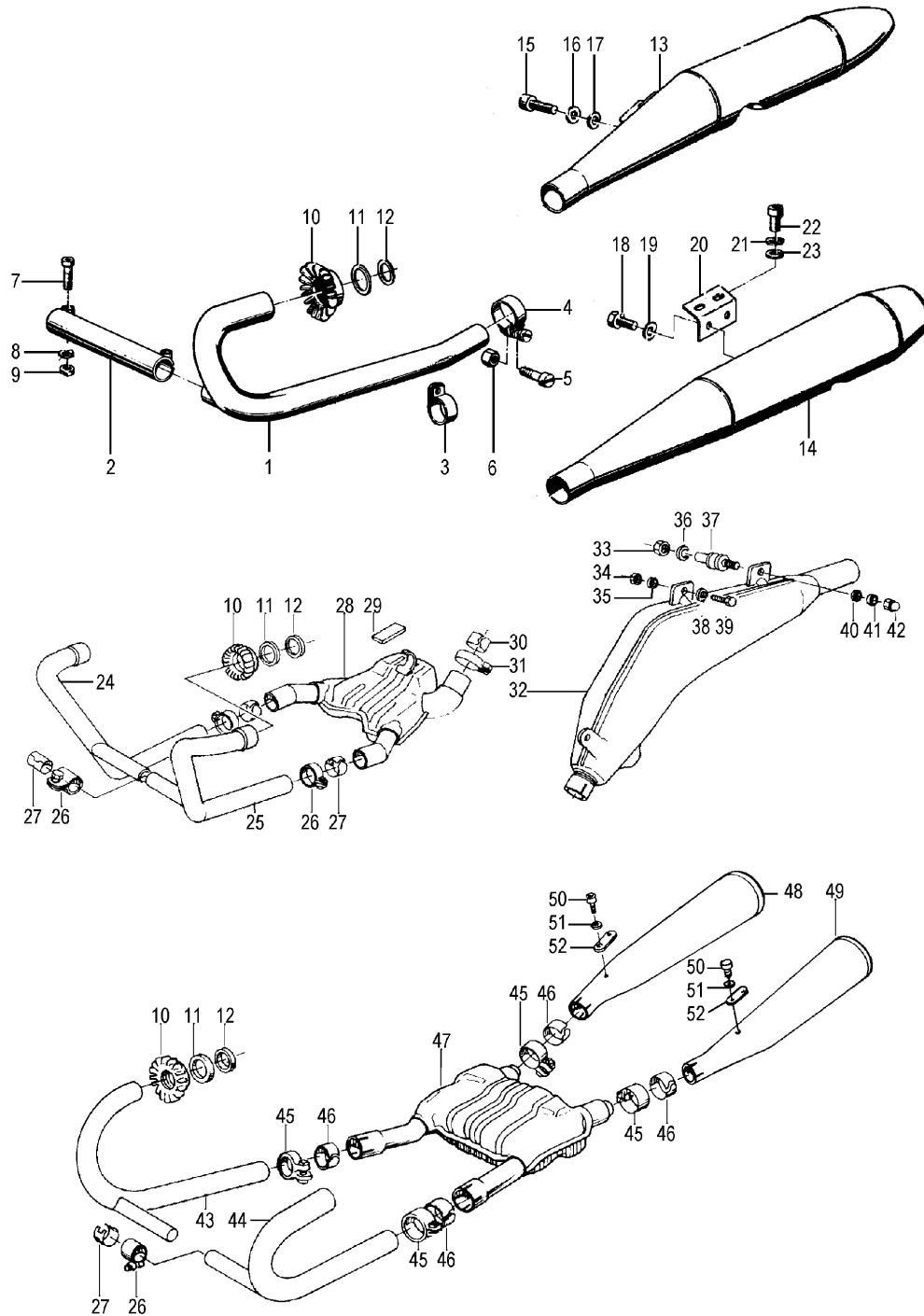

<u>Picture-No.</u>	<u>Article-No.</u>	<u>Description</u>	<u>Net</u>	<u>Gross</u>
18_000	9988100	Exhaust pipe cover for BMW R50/5-R100, Set complete with clamps stainless steel	52,86 €	62,90 €
18_000	1452066	Exhaust pipe for BMW R65 and R65RT SF from year of manufacture 09/1984, right side original BMW	129,83 €	154,50 €
18_000	1452065	Exhaust pipe for BMW R65 and R65RT SF from year of manufacture 09/1984, left side original BMW	129,83 €	154,50 €
18_000	9988101	Exhaust pipe cover for BMW R50/5-R100, single without clamp stainless steel	24,71 €	29,40 €
18_001a	1230434	Exhaust pipe for BMW R50/5-R100, 1st choice in-house production, Set with crosspipe 38mm	241,09 €	286,90 €
18_001aa	112001	Exhaust pipe for BMW R50/5-R100, Set with crosspipes 38mm, stainless steel	302,77 €	360,30 €
18_001b	1237149	Exhaust pipe for BMW R80/7-R100 from year of manufacture 1981, Set with 2 crosspipes NOT for models with oilcooler!!!!	232,44 €	276,60 €
18_001c	1234441	Exhaust pipe for BMW R100S, RS, RT, years of manufacture 1978-1980, left side 40mm	124,62 €	148,30 €
18_001c	1234442	Exhaust pipe for BMW R100S, RS, RT, years of manufacture 1978-1980, right side 40mm	124,62 €	148,30 €
18_001cc	0112002	Exhaust pipe for BMW R100S, RS, RT, CS, years of manufacture 1978 - 1980, Set with crosspipes, 40mm stainless steel	284,79 €	338,90 €
18_001d	1238272	Exhaust pipe for BMW R45 and R65 until year of manufacture 08/1980, right side	124,62 €	148,30 €



18_001d	1238271	Exhaust pipe for BMW R45 and R65 until year of manufacture 08/1980, left side	124,62 €	148,30 €
18_001e	1337218	Exhaust pipe for BMW R45 and R65 from year of manufacture 09/1980, right side for 2 crosspipes	105,63 €	125,70 €
18_001e	1337217	Exhaust pipe for BMW R45 and R65 from year of manufacture 09/1980, left side for 2 crosspipes	105,63 €	125,70 €
18_001g	30434	Exhaust pipe for BMW R50/5-R100, BMW original, left side	153,78 €	183,00 €
18_001i	2030434	Exhaust pipe for BMW R50/5-R100, 1st choice in-house production, left side 38mm	108,07 €	128,60 €
18_002	1238281	Crosspipe for BMW R45 and R65 from year of manufacture 1978, front (long) original BMW	75,88 €	90,30 €
18_002a	21035	Crosspipe for BMW R50/5-R100	28,15 €	33,50 €
18_002b	238281	Crosspipe for BMW R45 and R65 from year of manufacture 1978, front (long)	32,27 €	38,40 €
18_002c	337234	Crosspipe for BMW R45 and R65 from year of manufacture 1981, rear (short)	29,92 €	35,60 €
18_002d	302011	Crosspipe for BMW R65LS from year of manufacture 1981, front, (long), black	57,73 €	68,70 €
18_002e	302012	Crosspipe for BMW R65LS from year of manufacture 1981, rear, (short), black	61,18 €	72,80 €
18_002f	1230638	Crosspipe for BMW R50/5-R100 original BMW	76,05 €	90,50 €
18_002g	1337152	Crosspipe for BMW R80/7-R100 from year of manufacture 1981, rear original BMW	65,88 €	78,40 €
18_003a	1230587	Exhaust pipe clamp for BMW R50/5-R100 until year of manufacture 09/1984, left side for 38mm pipes, stainless steel	8,57 €	10,20 €
18_003b	1230432	Exhaust-pipe clamp for BMW R50/5-R100 until year of manufacture 09/1984, right side for 38mm pipes	10,34 €	12,30 €
18_003e	1238322	Exhaust pipe clamp for BMW R45 and R65 until year of manufacture 09/1984, left side	6,13 €	7,30 €
18_003f	1238274	Exhaust pipe clamp for BMW R45 and R65 until year of manufacture 09/1984, right side	6,13 €	7,30 €
18_004	1336553	Exhaust pipe clamp for BMW R50/5-R100, 38mm	5,55 €	6,60 €
18_004b	1336555	Clamp for muffler for BMW R50/5 to R100RT, for 40-43mm exhaust pipe Stainless steel	7,98 €	9,50 €
18_004c	1238282	Exhaust pipe clamp for BMW R45 and R65, R80G/S, until year of manufacture 09/1984 chrome plated	9,75 €	11,60 €
18_005	098820	Screw for muffler clamp, M 8 x 20, cylinder head-Allen® key stainless steel	0,67 €	0,80 €
18_005	98198	Screw M 8 x 20, cylinder-head Allen® key	0,42 €	0,50 €
18_010a	4090270	Exhaust nut for BMW R50/5-R90S "Big"	24,29 €	28,90 €
18_010b	1234721	Exhaust nut for BMW from R60/7 up "small"	18,32 €	21,80 €
18_010c	1335595	Exhaust nut for BMW R45 and R65 (fits also on R68, R69 and R69S)	20,00 €	23,80 €
18_011a	1230585	Exhaust thrust ring for BMW R50/5-R100, 38mm	4,37 €	5,20 €
18_011b	1234448	Exhaust thrust ring for BMW R100, 40mm	5,21 €	6,20 €
18_012a	1230586	Exhaust clamp ring for BMW R50/5-R100, 38mm	6,55 €	7,80 €
18_012b	1234449	Exhaust clamp ring for BMW R100, 40mm	7,73 €	9,20 €
18_012c	1335598	Exhaust clamp ring for BMW R45 and R65	16,55 €	19,70 €
18_013	32921	Muffler for BMW R50/5, R60/5 and R75/5, Cigar-shape, ECE approved, right side	207,65 €	247,10 €
18_013	11059	Muffler-Set for BMW R50/5-R100, Cigar shape, ECE approved 38mm, stainless steel polished	431,09 €	513,00 €
18_013	32920	Muffler for BMW R50/5, R60/5 and R75/5, Cigar-shape, ECE approved, left side	207,65 €	247,10 €
18_013	9012001	Heat-protection for silencers for BMW50/5-R100 up to year of manufacture 09/1984 stainless steel	27,73 €	33,00 €
18_013a	1232921	Muffler-Set for BMW R50/5-R75/5, Cigar shape, ECE not approved for 38mm and 40mm exhaust pipe (also usable for R60/6-R100RT)	173,03 €	205,90 €
18_013b	90120	Heat-protection set for silencers incl. clamps for BMW R50/5-R100 until year of manufacture 09/1984 stainless steel	60,50 €	72,00 €
18_014	233210	Muffler for BMW R60/6-R100, 38mm, ECE approved, left side until year of manufacture 09/1984	194,71 €	231,70 €
18_014	1233211	Muffler for BMW R60/6-R100, 38mm, right side original BMW	259,83 €	309,20 €
18_014	1233210	Muffler for BMW R60/6-R100, 38mm, left side original BMW	259,83 €	309,20 €
18_014	33211	Muffler for BMW R60/6-R100, 38mm, ECE approved, right side until year of manufacture 09/1984	194,71 €	231,70 €
18_014	2302013	Muffler for BMW R65LS, black, left side original BMW	268,32 €	319,30 €
18_014	2302014	Muffler for BMW R65LS, black, right side original BMW	268,32 €	319,30 €
18_014a	34453	Muffler for BMW R100S/RT/CS/RS, 40mm, ECE approved, right side	194,71 €	231,70 €
18_014a	34452	Muffler for BMW R100S/RT/CS/RS, 40mm, ECE approved, left side	194,71 €	231,70 €
18_014b	33210	Muffler-Set for BMW R60/6-R100RT, NOT ECE approved, 38mm and 40mm until year of manufacture 09/1984	143,45 €	170,70 €
18_014d	38276	Muffler for BMW R45 and R65 until to year of manufacture 09/1984, ECE approved, chrome, right side	194,71 €	231,70 €
18_014d	38275	Muffler for BMW R45 and R65 until to year of manufacture 09/1984, ECE approved, chrome, left side	194,71 €	231,70 €
18_014e	700351	Muffler for BMW R50/5-R100, Sport-shape, 38mm, NOT ECE approved, right side	160,08 €	190,50 €
18_014e	70351	Muffler for BMW R50/5-R100, Sport-shape, 38mm, NOT ECE approved, left side	160,08 €	190,50 €
18_014f	700352	Muffler for BMW R100S/RT/CS/RS, SportShape, 40mm, NOT ECE approved, right side	160,08 €	190,50 €
18_014f	70352	Muffler for BMW R100S/RT/CS/RS, SportShape, 40mm, NOT ECE approved, left side	160,08 €	190,50 €



18_020	1233033	Exhaust angle bracket for BMW R50/5-R100, year of manufacture from 1969 until 09/1984	6,22 €	7,40 €
18_020a	14025	Exhaust angle bracket for BMW R50/5-R100, year of manufacture from 1969 until 09/1984 stainless steel	14,37 €	17,10 €
18_024	1452500	Exhaust pipe for BMW R80GS-R100PD year of manufacture 1988 - 1995, right side and R80R, R100R/MYS until year of manufacture 1995, original BMW	146,64 €	174,50 €
18_024	1458192	Exhaust pipe for BMW R65GS, right side chromed, original BMW --- DELIVERY TIME: at the earliest of may 2018	168,99 €	201,10 €
18_025	1452399	Exhaust pipe for BMW R80GS-R100PD, years of manufacture 1988 - 1995, left side and R80R, R100R/MYS until year of manufacture 1995, original BMW	146,64 €	174,50 €
18_025	1458191	Exhaust pipe for BMW R65GS, left side chromed, original BMW	168,99 €	201,10 €
18_026	1454638	Exhaust pipe clamp crosspipe for BMW R65 from year of manufacture 09/1984 and for BMW R80GS, R100GS, R80R and R100R from year of manufacture 1988, 27mm	24,71 €	29,40 €
18_026a	1457663	Exhaust pipe clamp for BMW R80GS-100PD from year of manufacture 09/1987, left side and for BMW R80R und R100R	11,18 €	13,30 €
18_026b	1457664	Exhaust pipe clamp for BMW R80GS-100PD from year of manufacture 09/1987, right side and for BMW R80R und R100R	11,18 €	13,30 €
18_026c	1454636	Exhaust pipe clamp, crosspipe for BMW R80-100RT from year of manufacture 09/1984 31mm	22,94 €	27,30 €
18_027	1454639	Gasket x-pipe for BMW R65 until year of manufacture 1985, R80-R100GS, PD, R, 27mm	9,50 €	11,30 €
18_027	1454637	Gasket for x-pipe R65-R100RT, from year of manufacture 09/1984, 31mm	6,55 €	7,80 €
18_027	2331956	Gasket exhaust pipes for BMW R80GS-R100PD and R80/R100R from year of manufacture 09/1987	10,59 €	12,60 €
18_028	2113002	Front muffler for BMW R80ST, R65GS and R80G/S years of manufacture 09/1980-09/1988 stainless steel	212,10 €	252,40 €
18_028	6322094	Front muffler (Y-pipe) for BMW R80GS, R100GS and R80GS Basic, from year of manufacture 09/1988 stainless steel, ECE approved	241,51 €	287,40 €
18_029	1457940	Rubber pad for BMW R80R/GS/Basic, R100R and R100GS	1,34 €	1,60 €
18_032	8111013	Muffler for BMW R65GS-R80ST, R100GS/PD, ECE approved, Manufacturer: Sito years of manufacture 1980 until 1996, (also for paralever), not original shape!	268,24 €	319,20 €
18_032a	8111007	Muffler for BMW R65GS-R80ST, R100GS/PD, ECE approved years of manufacture 1980 until 1996, stainless steel polished (also for paralever)	475,29 €	565,60 €
18_037	2310861	Exhaust rubber bearing for BMW R80GS and R100GS	13,78 €	16,40 €
18_043	1452182	Exhaust pipe for BMW R80 and R80RT, years of manufacture 09/1984-1995, right side and R100RS, R100RT, years of manufacture 1987-1995, original BMW	150,00 €	178,50 €
18_043a	1457928	Exhaust pipe for BMW R100RT and R100RS, years of manufacture 1987-1995, right side original BMW	143,61 €	170,90 €
18_044	1452181	Exhaust pipe for BMW R80 and R80RT, years of manufacture 09/1984-1995, left side and R100RS, R100RT, years of manufacture 1987-1995, original BMW	150,00 €	178,50 €
18_045	1454379	Exhaust pipe clamp for BMW R65-R100 from year of manufacture 09/1984, left side for 43mm pipes	15,55 €	18,50 €
18_045a	1454381	Exhaust pipe clamp for BMW from year of manufacture 09/1984, diameter= 49mm, left side Original BMW	13,28 €	15,80 €
18_045b	1454380	Exhaust pipe clamp for BMW R65-R100 from year of manufacture 09/1984, right side for 43mm pipes	18,74 €	22,30 €
18_045c	6580100	Exhaust pipe clamp for BMW R65-R100 from year of manufacture 09/1984 chrome plated	6,89 €	8,20 €
18_046	2331955	Gasket for muffler/collector for BMW R65-R100RT from year of manufacture 09/1984 and for BMW R80GS-R100PD from year of manufacture 09/1987, rear	9,24 €	11,00 €
18_046	1454656	Gasket exhaust pipe for BMW R65-R100, from year of manufacture 09/1984, front, 43mm	8,24 €	9,80 €
18_046a	1454382	Exhaust pipe clamp for BMW from year of manufacture 09/1984, diameter= 49mm, right side Original BMW	11,18 €	13,30 €
18_047	1452097	Front muffler for BMW R65, R80, R100 from year of manufacture 09/1984	432,35 €	514,50 €
18_047	6321097	Front muffler (H-pipe) for BMW R65, R80 and R100 from year of manufacture 09/1984 stainless steel, ECE approved (NO exhaust pipes gasket needed)	232,86 €	277,10 €
18_048	58362	Muffler for BMW R65, R65RT SF, R80 and R80RT, ECE approved, right side from year of manufacture 1985	205,63 €	244,70 €
18_049	58361	Muffler for BMW R65, R65RT SF, R80 and R80RT, ECE approved, left side from year of manufacture 1985	205,63 €	244,70 €
18_050	98193	Screw M 8 x 16, Allen® key	0,25 €	0,30 €
18_999	61922	Grommet muffler-attachment for BMW R80R, R100R, R80GS and R100GS	1,43 €	1,70 €
18_999	90139	Wrench for finned exhaust nut forged steel, professional workshop quality	24,29 €	28,90 €
18-001h	2030433	Exhaust pipe for BMW R50/5-R100, 1st choice in-house production, right side 38mm	108,07 €	128,60 €



Group 21 Clutch

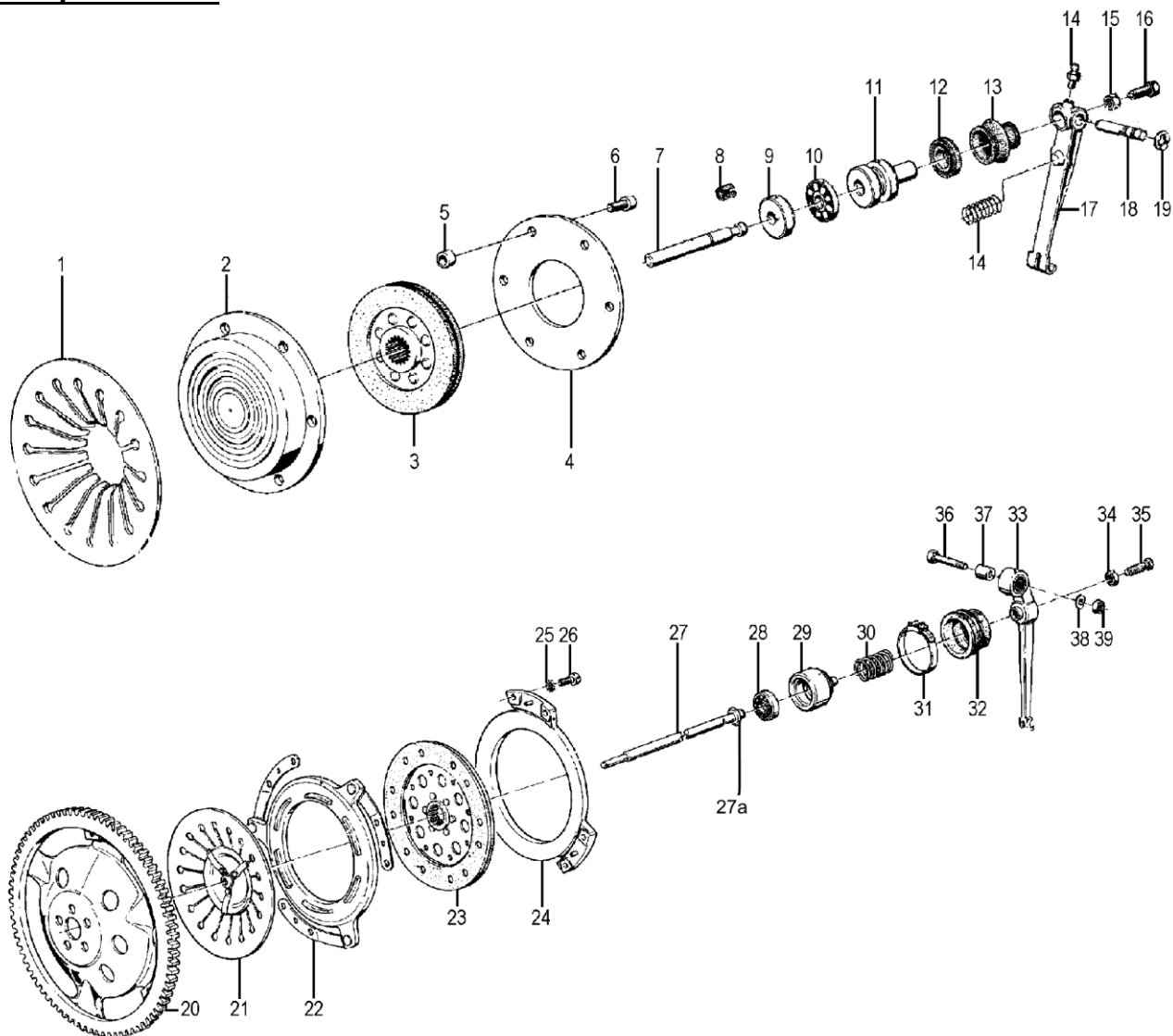

<u>Picture-No.</u>	<u>Article-No.</u>	<u>Description</u>	<u>Net</u>	<u>Gross</u>
21_001a	1250288	Clutch spring for BMW R50/5-R80/7 until year of manufacture 09/1980	57,90 €	68,90 €
21_001b	1234035	Clutch spring for BMW R90/6, R90S and R100 until year of manufacture 09/1980	47,23 €	56,20 €
21_001c	1237573	Clutch spring for BMW R45 and R65 until year of manufacture 09/1980	97,06 €	115,50 €
21_002a	1251801	Pressure plate clutch for BMW R50/5-R100 from year of manufacture 09/1969-09/1980, front	63,19 €	75,20 €
21_002a	0051801	Pressure plate clutch for BMW R50/5-R100 from year of manufacture 09/1969-09/1980, front ORIGINAL BMW	106,81 €	127,10 €
21_002b	1237567	Pressure plate clutch for BMW R45 and R65 until year of manufacture 09/1980, front	84,62 €	100,70 €
21_003a	5054	Clutch friction disc for BMW R50/5-R100 until year of manufacture 09/1980	57,14 €	68,00 €
21_003b	37571	Clutch friction disc for BMW R45 and R65 until year of manufacture 09/1980	53,19 €	63,30 €
21_004a	1231666	Thrust ring clutch for BMW R50/5-R100 from year of manufacture 09/1969-09/1980, rear	95,13 €	113,20 €
21_005	70511	Spacer washer clutch for BMW R50-R69S and R50/5-R75/5 only for pressure ring "without edge"	4,29 €	5,10 €
21_006	31463	Screw for clutch for BMW R50/5-R100 until 09/1980, cylinder head-Allen® key	1,51 €	1,80 €
21_007a	1230106	Clutch thrust rod for BMW R50/5, R60/5 and R75/5	13,78 €	16,40 €
21_007b	1232089	Clutch thrust rod for BMW R60/6-R100 until year of manufacture 09/1980	29,41 €	35,00 €
21_008	20132	Felt for clutch push rod for BMW R24-R27 and R50-R100 for mounting cut diagonally	2,77 €	3,30 €
21_009	30962	Thrust bearing, clutch for BMW R24-R26 and R51/2-R69S and BMW R50/5 until year of manufacture 09/1973	9,50 €	11,30 €
21_009b	1232088	Thrust washer for needle bearing for BMW models from year of manufacture 09/1973-09/1980	15,63 €	18,60 €
21_010a	30961	Thrust bearing clutch ball bearing for BMW models until year of manufacture 09/1973	22,10 €	26,30 €
21_010b	1232079	Thrust bearing clutch needle bearing for BMW models from year of manufacture 09/1973-09/1980	27,48 €	32,70 €
21_011a	1230107	Clutch thrust piece ball for BMW R50/5, R60/5 und R75/5, years of manufacture 09/1969-09/1973	46,89 €	55,80 €



21_011b	1232087	Clutch thrust piece needle for BMW R45/R65 and R60/6-R100, years of manufacture 09/1973-09/1980	38,07 €	45,30 €
21_012	20109	Sealring for clutch thrust piece	2,61 €	3,10 €
21_013	30109	Dust cover for clutch release lever for BMW models until year of manufacture 09/1980	9,08 €	10,80 €
21_014a	80122	Clutch lever spring until year of manufacture 08/1973	1,76 €	2,10 €
21_014b	1234034	Clutch lever spring from year of manufacture 09/1973 until 08/1980	6,89 €	8,20 €
21_016a	30108	Adjusting screw for clutch release lever for BMW R26-R27, R50-69S, R50/5 until year of manufacture 09/1980, M8	2,61 €	3,10 €
21_016b	1241848	Adjusting screw for clutch release lever from year of manufacture 09/1980, M8	5,38 €	6,40 €
21_017	1230104	Clutch release lever for BMW R50/5-R75/5 (at gear-box)	78,99 €	94,00 €
21_018a	1230090	Bolt clutch release lever for BMW R50/5-R75/5	5,04 €	6,00 €
21_018b	1241484	Bolt clutch release lever for BMW R60/6-R100	18,15 €	21,60 €
21_019a	9932852	Clutch release lever washer from year of manufacture 09/1973, 7mm	1,76 €	2,10 €
21_019b	1864963	Clutch release lever Lock plate from year of manufacture 09/1973	3,87 €	4,60 €
21_019c	9934208	Clutch release lever washer for BMW R60/6-R90S, 8mm	2,18 €	2,60 €
21_020	38722	Fly wheel for BMW-models from year of manufacture 1981 light clutch with gear ring	151,34 €	180,10 €
21_021	1242353	Clutch spring for BMW R45-R100, years of manufacture 09/1980-09/1984 and for BMW R100 from year of manufacture 1987 and R80R/R100R	54,71 €	65,10 €
21_022	2302200	Pressure plate clutch for BMW R45-R100 from year of manufacture 09/1980, front light clutch from year of manufacture 09/1980	61,01 €	72,60 €
21_023a	1451512	Clutch friction disc for BMW R45-R100 from year of manufacture 09/1980 (light clutch) Original	104,62 €	124,50 €
21_023b	4054	Clutch friction disc for BMW R45-R100 from year of manufacture 09/1980 (light clutch)	53,19 €	63,30 €
21_024	1457280	Thrust ring clutch for BMW R80/7-R100 from year of manufacture 09/1980, rear light clutch for BMW R45 and R65 years of manufacture 1978-1985	128,24 €	152,60 €
21_025	1242377	Serrated lock washer for clutch screw for BMW models from year of manufacture 09/1980	1,26 €	1,50 €
21_026	38680	Screw for clutch for BMW R80-R100 from year of manufacture 09/1980	1,76 €	2,10 €
21_027	41844	Clutch thrust rod for BMW R80-R100 from year of manufacture 09/1980	66,39 €	79,00 €
21_028	9984020	Bearing clutch thrust rod for BMW R45-R100 for "light" clutch from year of manufacture 09/1980	27,14 €	32,30 €
21_029	1464167	Clutch thrust piece for all BMW models from year of manufacture 09/1980 light model	58,66 €	69,80 €
21_030	1241849	Clutch lever spring from year of manufacture 09/1980	3,11 €	3,70 €
21_031	41872	Clamp clutch boot for BMW models from year of manufacture 09/1980	2,94 €	3,50 €
21_032	1338731	Dust cover for clutch release lever for BMW models from year of manufacture 09/1980	16,97 €	20,20 €
21_033a	1241847	Clutch release lever for BMW from year of manufacture 09/1980 (at gear-box)	54,96 €	65,40 €
21_033b	1238422	Needle bushing for shift lever / clutch lever for BMW R50/5-R100	10,34 €	12,30 €
21_033b	1234049	Clutch release lever for BMW from /6 until year of manufacture 09/1980 (at gear-box)	120,67 €	143,60 €
21_035	1241848	Adjusting screw for clutch release lever from year of manufacture 09/1980, M8	5,38 €	6,40 €
21_037	1241833	Bushing for clutch release lever from year of manufacture 09/1980	9,50 €	11,30 €
21_999	45182	Split pin for clutch lever for BMW R50/5, R60/5 and R75/5	0,25 €	0,30 €



Group 23a FourSpeed gearbox

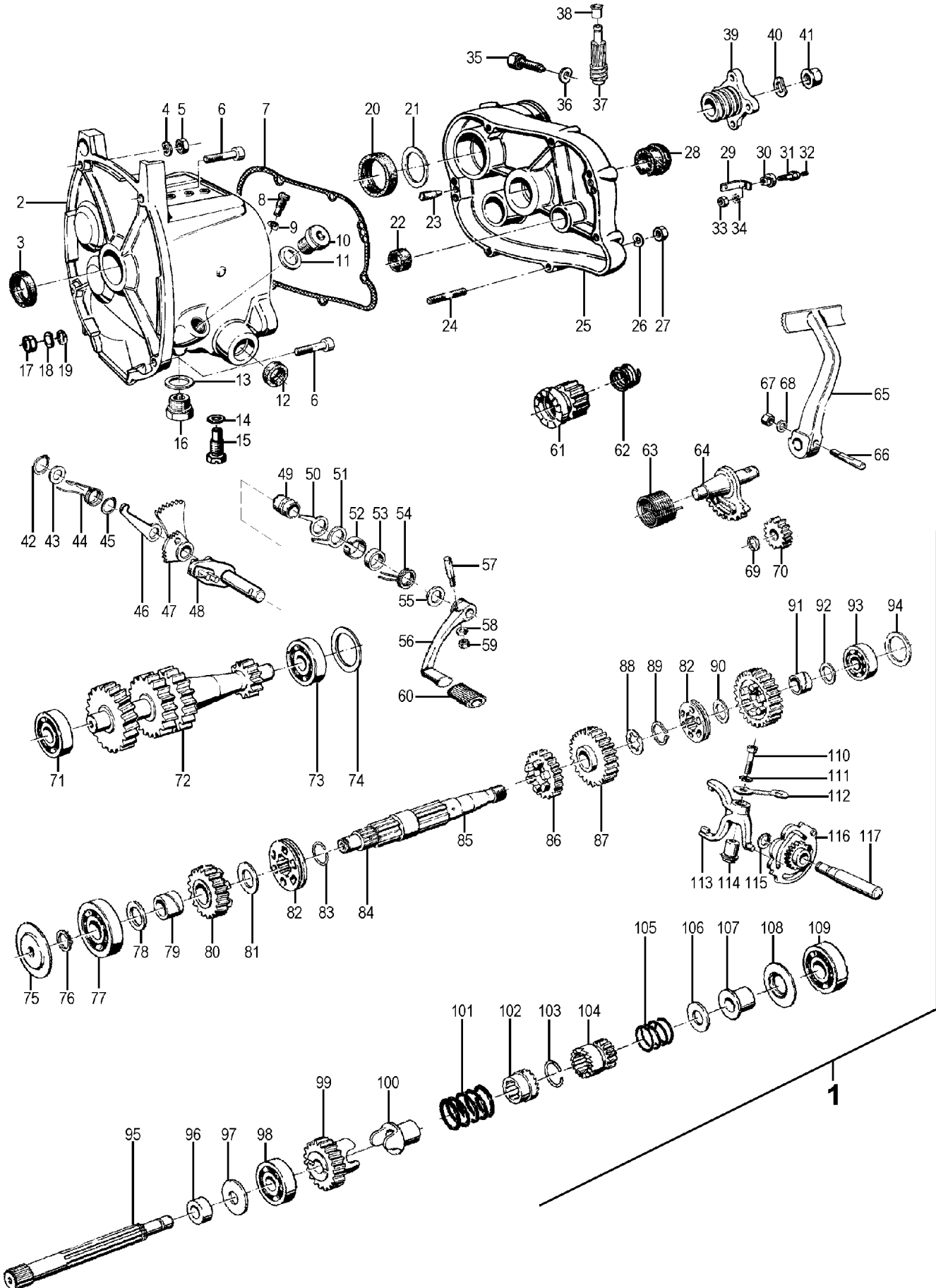

<u>Picture-No.</u>	<u>Article-No.</u>	<u>Description</u>
23a	19124	Oil drain screw / Oil filler screw for BMW R50/5-R100, M18, hexagon
23a_0	66102	Wedge for shift pedal for BMW R24-R69S zincd

<u>Net</u>	<u>Gross</u>
3,28 €	3,90 €
3,95 €	4,70 €



23a_00	98457	Spring washer B 8,4, DIN137B-A2 stainless steel	0,25 €	0,30 €
23a_000	991140	Gearbox input repair kit for BMW R24-R27, R50-R69S and R50/5-R75/5 Speedy sleeve	39,16 €	46,60 €
23a_000	1231523	Gear-wheel 1st gear for BMW R60/6-R100 until year of manufacture 1982	62,44 €	74,30 €
23a_000	99982	Gasket set gearbox (No.G07), for BMW R50/5-R75/5	24,54 €	29,20 €
23a_002	1234036	Gearbox 4-speed for BMW R50/5-R75/5 overhauled	947,82 €	1.127,90 €
23a_003	30088	Radial seal ring, gearbox input for BMW R50/5, R60/5 and R75/5	4,03 €	4,80 €
23a_005b	98353	Nut M 8 stainless steel	0,42 €	0,50 €
23a_006	98206	Screw M 8 x 40, cylinder-head Allen® key	0,50 €	0,60 €
23a_007	06280	Gearbox cover gasket for 4-speed-transmission, 2-cylinders, years of manufacture 1955-1973	2,44 €	2,90 €
23a_013	2027	Gasket ring oil drain screw, M14x20x2	0,76 €	0,90 €
23a_016	07163	Oil drain screw for BMW R24-R69S, M14, magnetic zincked	3,28 €	3,90 €
23a_016a	07104	Oil filler screw for BMW R24-R69S, M14 x 1,5 zincked	2,10 €	2,50 €
23a_020	30087	Radial seal ring, gearbox output for BMW R50/5, R60/5 and R75/5	6,30 €	7,50 €
23a_022	02196	Radial seal ring, crankshaft front for BMW R51/3-R60 old and R68, R69 Kickstarter R24-R27, R50-R69S, / 5 + 5 speed gearbox	3,87 €	4,60 €
23a_028	06174	Rubber plug for idle connection for BMW R25/2-R69S	4,37 €	5,20 €
23a_031	06158	Idle indicator switch contact bolt for BMW R25/2-R27 and R51/3-R69S	11,60 €	13,80 €
23a_037	3005801	Speedo drive for BMW R50/5, R60/5 and R75/5 4-gear-transmission	42,35 €	50,40 €
23a_038	30176	Bushing speedo-cable for BMW R26-R69S and R50/5-R100 thin end	3,28 €	3,90 €
23a_039	1230057	Gearbox flange for BMW R50/5-R75/5	89,08 €	106,00 €
23a_041	30084	Drive shaft nut, M16 with bund	7,56 €	9,00 €
23a_044	66131	Spring latch for BMW R50-R69S and R50/5-R75	7,14 €	8,50 €
23a_055	06253	Radial seal ring, foot shift lever for BMW R51/2-R68, R45/R65 and R60/6-R100 from year of manufacture 09/1974 and GS-Models	3,53 €	4,20 €
23a_055	32248	Radial seal ring, foot shift lever for BMW R60/6-R90S until year of manufacture 09/1974	3,53 €	4,20 €
23a_056	1239023	Rocker switch for BMW R60/6-R80TIC until year of manufacture 09/1980 ONLY 5-gear-transmission!	123,36 €	146,80 €
23a_056	66245	Foot-Shift lever for BMW R50-R69S and R50/5-R75/5 used	62,18 €	74,00 €
23a_057	66103	Wedge for shift pedal for BMW R24-R69S stainless steel	6,72 €	8,00 €
23a_060	45016	Shift lever rubber for BMW R24-R69S and R50/5-R75/5	1,60 €	1,90 €
23a_060	1232097	Shift lever rubber for BMW 5-speed-transmission	1,34 €	1,60 €
23a_063	56112	Kick starter spring for BMW R24-R27, R50-R69S and R50/5-R75/5	5,88 €	7,00 €
23a_066	50016	Mounting bolt for kick starter for BMW R24-R27, R50-R69S and R50/5-R100 zinced	4,29 €	5,10 €
23a_069	34080	Lock ring kickstarter gear for BMW R24-R27, R50-R69S and R50/5-R75/5R69S	0,25 €	0,30 €
23a_070	56108	Kick starter intermediate gear for BMW R24-R27, R50-R69S and R50/5-R75/5	84,20 €	100,20 €
23a_071	15064	Bearing auxiliary shaft for BMW R24-R27 and R50-R69S, front front/rear wheel R25-R25/3	23,36 €	27,80 €
23a_072	30068	Intermediate gear box shaft for BMW R50/5, R60/5 and R75/5	389,50 €	463,50 €
23a_072a	1231206	Gearbox-part: Auxiliary shaft Sports R50/5, R60/5, R75/5 4-speed gearbox	302,94 €	360,50 €
23a_073	6203	Bearing cam shaft R24-R69S, crankshaft R51/3-R69S, front end, with 17mm cone wheel bearing R25-R25/2, pinion shaft R24, auxiliary shaft /5 4-gear box, crankshaft most front R51/3-R69	6,47 €	7,70 €
23a_074	1230966	Distance washer intermediate shaft for BMW R50/5-R75/5, 0,18mm	1,93 €	2,30 €
23a_074	1230969	Distance washer intermediate shaft für BMW R50/5-R75/5, 0,50mm	1,76 €	2,10 €
23a_075	1230075	Oil drip pan output shaft for BMW R50/5 and up	16,97 €	20,20 €
23a_077	6064	Bearing output shaft for BMW R60/6-R100, front and /5 4-gear box	21,51 €	25,60 €
23a_078	1230089	Thrust washer gearbox output shaft for BMW R50/5-R75/5	1,68 €	2,00 €
23a_079	1230081	Bushing for BMW R50/5-R75/5, 4th gear-wheel	17,23 €	20,50 €
23a_080	1230060	Gear-wheel 4th gear outputshaft for BMW R50/5, R60/5 and R75/5, 4-speed gearbox	198,49 €	236,20 €
23a_081	1231616	Washer output shaft for BMW R50/-R100 only for "Sport"-gearbox	3,03 €	3,60 €
23a_082	30082	Sliding claw for BMW R50/5, R60/5 und R75/5, USED	34,62 €	41,20 €
23a_085	1230077	Gearbox outlet shaft for BMW R50/5-R75/5	288,40 €	343,20 €
23a_086	1230062	Gear-wheel 3rd gear outputshaft for BMW R50/5, R60/5 and R75/5, 4-speed gearbox	148,91 €	177,20 €
23a_086a	1231211	Gear-wheel 3rd gear for BMW R50/5, R60/5 and R75/5, Sport	163,61 €	194,70 €
23a_087	1230064	Gear-wheel 2nd gear outputshaft for BMW R50/5, R60/5 and R75/5, 4-speed gearbox	146,30 €	174,10 €
23a_087a	1231210	Gear-wheel 2nd gear for BMW R50/5, R60/5 and R75/5, Sport	163,61 €	194,70 €
23a_090A	1230066	Gear-wheel 1st gear outputshaft for BMW R50/5, R60/5 and R75/5, 4-speed gearbox	164,71 €	196,00 €
23a_090B	1231209	Gear-wheel 1st gear for BMW R50/5, R60/5 and R75/5, Sport	163,61 €	194,70 €
23a_091	1030259	Bushing for BMW R50/5-R75/5, 1st gear-wheel	30,67 €	36,50 €
23a_092	1231630	Shim for gearbox output shaft for BMW R50/5-R100 and 4 und 5. gear	4,54 €	5,40 €
23a_093	4064	Bearing crank shaft for BMW R24-R27 front end and /5 4-speed gearbox and for BMW R24-R69S input shaft front and output shaft rear	7,56 €	9,00 €
23a_095	1230455	Gearbox drive shaft for BMW R50/5-R75/5	159,66 €	190,00 €



23a_097	1230447	Bearing cover ring for BMW R50/5, R60/5 and R75/5	1,09 €	1,30 €
23a_098	1064	Grooved ball bearing gearbox outlet shaft for BMW R51/2-R68, front and rear and for BMW /5 - 4-gear- and 5-gearbox	7,98 €	9,50 €
23a_099	1230085	Gear-wheel drive shaft for BMW R50/5, R60/5 and R75/5	170,50 €	202,90 €
23a_100	1233425	Drive thrust piece power-in shaft for BMW R45/R65, R50/5-R100, R80G/S, ST, 35mm	69,75 €	83,00 €
23a_101	1231303	Pressure spring drive shaft for BMW R60/6-R100	9,75 €	11,60 €
23a_103	20148	Lock ring input shaft for BMW R24-R27, R50-R69S and R50/5-R75/5	0,67 €	0,80 €
23a_107	1231392	Bushing input-shaft for BMW R50/5-R75/5	6,64 €	7,90 €
23a_112	1230093	Retaining sheet metal for BMW /5, 4th gear	3,45 €	4,10 €
23a_113a	230100	Shifter fork for BMW R50/5, R60/5 and R75/5 original BMW	93,53 €	111,30 €
23a_113b	1069	Shifter fork for BMW R50/5, R60/5 and R75/5	76,22 €	90,70 €
23a_114	1230086	Excenter bushing shifter fork for BMW R24-R90S	25,63 €	30,50 €
23a024	03209	Stud bolt valve cover for BMW R51/3-R69S, timing cover R24-R69S gearbox cover R24-R69S and /5 4-gear, M6x25	1,60 €	1,90 €



Group 23b FiveSpeed gearbox

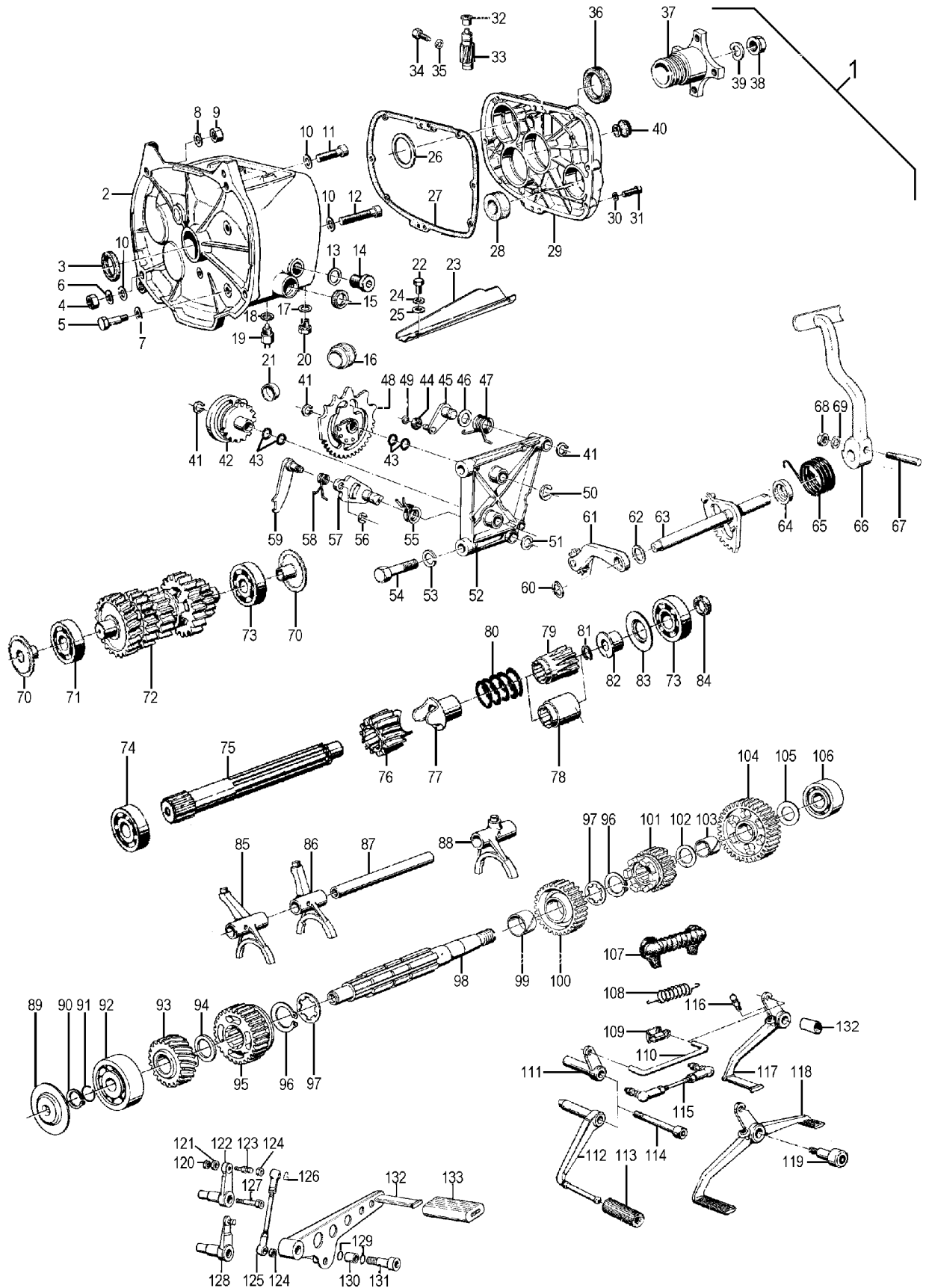

<u>Picture-No.</u>	<u>Article-No.</u>	<u>Description</u>	<u>Net</u>	<u>Gross</u>
23b_000	6000003	Bearing kit for R60/6-R100 from year of manufacture 09/1974	145,04 €	172,60 €
23b_000	6000001	Gasket set gearbox (No.G08), for BMW R60/6-R100 until Sep 1980 with and without kickstarter	36,30 €	43,20 €



23b_000	1234213	Gear wheel 4th gear for BMW R60/6-R100 until year of manufacture 1982	137,14 €	163,20 €
23b_000	31527	Gear-wheel 2nd gear for BMW R60/6-R100 until year of manufacture 1982	63,11 €	75,10 €
23b_000	99387	Gear-wheel auxiliary-shaft R60/6-R100, 15°, used without "X" - Mark	53,28 €	63,40 €
23b_000	99388	Gear-wheel, auxiliary-shaft R60/6-R100, 17,5° "with ""X""- mark"	132,35 €	157,50 €
23b_002a	40767	Gearbox 5-speed with kickstarter, until year of manufacture 1981 overhauled	1.034,37 €	1.230,90 €
23b_002b	1242415	Gearbox 5-speed with kick starter, from year of manufacture 1981 and later overhauled	1.034,37 €	1.230,90 €
23b_002c	1240766	Gearbox 5-speed without kickstarter, until year of manufacture 1981 overhauled	947,82 €	1.127,90 €
23b_002d	1242417	Gearbox 5-speed without kickstarter, from year of manufacture 1981 and later overhauled	947,82 €	1.127,90 €
23b_002e	1240767	Gearbox 5-speed with kickstarter, until year of manufacture 1981 NEW	1.531,93 €	1.823,00 €
23b_003	32249	Radial seal ring, gearbox input for BMW R45/R65, R60/6-R100, 5-speed models	4,54 €	5,40 €
23b_007	22083	Spring washer B10, DIN137A zincked	0,17 €	0,20 €
23b_010	98414	Washer M 8, DIN125, Form A cined	0,08 €	0,10 €
23b_011	98206	Screw M 8 x 40, cylinder-head Allen® key	0,50 €	0,60 €
23b_012	33474	Distance washer gearbox outlet shaft for BMW R51/3-R68 and all 5-gear, 0,10mm	1,60 €	1,90 €
23b_012a	33475	Distance washer gearbox outlet shaft for BMW R51/3-R68 and all 5-gear, 0,20mm	1,60 €	1,90 €
23b_012b	31625	Distance washer gearbox outlet shaft for BMW R51/3-R68 and all 5-gear, 0,30mm	1,68 €	2,00 €
23b_012c	31626	Distance washer gearbox outlet shaft for BMW R51/3-R68 and all 5-gear, 0,38mm	9,08 €	10,80 €
23b_012d	31627	Distance washer gearbox outlet shaft for BMW R51/3-R68 and all 5-gear, 0,50mm	1,68 €	2,00 €
23b_013	63300	Gasket ring, 18x22x1,5 - aluminium	0,25 €	0,30 €
23b_014	19124	Oil drain screw / Oil filler screw for BMW R50/5-R100, M18, hexagon	3,28 €	3,90 €
23b_014a	07104	Oil filler screw for BMW R24-R69S, M14 x 1,5 zincked	2,10 €	2,50 €
23b_014a	0007104	Oil filler screw for BMW R24-R69S, M14 x 1,5 stainless steel, polished	6,97 €	8,30 €
23b_015	06253	Radial seal ring, foot shift lever for BMW R51/2-R68, R45/R65 and R60/6-R100 from year of manufacture 09/1974 and GS-Models	3,53 €	4,20 €
23b_015	32248	Radial seal ring, foot shift lever for BMW R60/6-R90S until year of manufacture 09/1974	3,53 €	4,20 €
23b_017	2028	Gasket ring, 14x18x1,5 - Aluminum	0,25 €	0,30 €
23b_018	63130	Gasket ring, 12x16x1,5 - aluminium	0,25 €	0,30 €
23b_019a	52153	Idle indicator switch for BMW R60/6-R90S until year of manufacture 09/1975	30,50 €	36,30 €
23b_019b	43097	Idle indicator switch for BMW R60/6-R100 from year of manufacture 09/1975 please also order article nr 1355262	21,60 €	25,70 €
23b_020	07163	Oil drain screw for BMW R24-R69S, M14, magnetic zincked	3,28 €	3,90 €
23b_024	98406	Washer M 4, DIN125 cined	0,08 €	0,10 €
23b_027	1338596	Gearbox cover gasket for 5-speed-transmission	3,45 €	4,10 €
23b_028	02196	Radial seal ring, crankshaft front for BMW R51/3-R60 old and R68, R69 Kickstarter R24-R27, R50-R69S, / 5 + 5 speed gearbox	3,87 €	4,60 €
23b_029	1234037	Gearbox cover for 5-speed with kickstarter, until year of manufacture 09/1980 used	164,45 €	195,70 €
23b_029a	1241832	Gearbox cover for 5-speed with kickstarter, from year of manufacture 09/1980	158,32 €	188,40 €
23b_029b	1241831	Gearbox cover 5-speed without kickstarter, new version	159,24 €	189,50 €
23b_029c	1233948	Gearbox cover 5-speed without kickstarter, until year of manufacture 09/1980	225,29 €	268,10 €
23b_030	98410	Washer M 6, DIN125, Form A cined	0,08 €	0,10 €
23b_031	98158	Screw M 6 x 20, cylinder-head Allen® key, flat-head	0,50 €	0,60 €
23b_032	30176	Bushing speedo-cable for BMW R26-R69S and R50/5-R100 thin end	3,28 €	3,90 €
23b_034	30599	Speedo cable screw with breather hole for BMW R50/5 and up tachometer screw	7,90 €	9,40 €
23b_036	1338514	Radial seal ring, gearbox output for BMW moldels from year of manufacture 09/1987, Teflon	19,58 €	23,30 €
23b_036	32681	Radial seal ring, gearbox output for BMW R45/R65, R60/6-R100 until year of manufacture 09/1987	6,81 €	8,10 €
23b_037	1232557	Gearbox flange, 5-speed	183,03 €	217,80 €
23b_038	30084	Drive shaft nut, M16 with bund	7,56 €	9,00 €
23b_039	98462	Spring washer B16, DIN137 zincked	0,42 €	0,50 €
23b_040	30109	Dust cover for clutch release lever for BMW models until year of manufacture 09/1980	9,08 €	10,80 €
23b_042	1451563	Shifting cam segment 3/4-gear-transmission for BMW R60/6-R100 and R65GS-R100GS from 1975	112,52 €	133,90 €
23b_044a	31572	Shifter scenery roll for BMW R60/6-R100	4,54 €	5,40 €
23b_044b	1231572	Shifter scenery ball bearing for BMW R60/6-R100	4,79 €	5,70 €
23b_047	34791	Shift lever return spring for BMW R60/6-R100R from year of manufacture 09/1975 and for BMW R65GS-R100GS from year of manufacture 09/1980	3,28 €	3,90 €
23b_047a	31639	Shift lever return spring for BMW R50/5-R90S until year of manufacture 09/1975	11,60 €	13,80 €
23b_048	1231611	Shifting cam segment 1/2/5 5-gear-transmission for BMW R50/5-R100R and R65GS-R100GS	112,52 €	133,90 €
23b_050	9932881	Lock washer for shafts, Ø 10,00mm	0,50 €	0,60 €
23b_052	1231664	Bearing block R50/5, R60/5, R75/5, R60/6, R75/6, R90/6, R90S until 09/76, 5-speed transmission	77,31 €	92,00 €
23b_055	31618	Spring segment shaft for BMW R60/6-R100	4,54 €	5,40 €
23b_056	32841	Lock ring chain tensioner for BMW R50/5-R100 until year of manufacture 1979 and gear for BMW R60/6-R100R and R65GS-R100GS	0,59 €	0,70 €



23b_058	1242910	Spring for latch for BMW R50/5-R100	2,02 €	2,40 €
23b_059	1242892	Kick starter ratchet for BMW R60/6-R100R	21,26 €	25,30 €
23b_060	9934100	Lock ring kickstarter and output shaft for BMW R50/5-R100	0,92 €	1,10 €
23b_061	1231673	Holder for kick starter shaft for BMW R50/5-R100PD	38,82 €	46,20 €
23b_062	1232090	Washer kickstarter for BMW R60/6-R100, front	1,68 €	2,00 €
23b_063	1338609	Kick starter section gear for BMW R60/6-R100	187,31 €	222,90 €
23b_064	1232049	Washer kickstarter for BMW R60/6-R100, rear	12,94 €	15,40 €
23b_065	1231682	Kick starter spring for BMW R60/6-R100	6,30 €	7,50 €
23b_066	1230055	Kick starter for BMW R50/5-R100, with bend	126,64 €	150,70 €
23b_067a	50016	Mounting bolt for kick starter for BMW R24-R27, R50-R69S and R50/5-R100 zinced	4,29 €	5,10 €
23b_067b	56124	Mounting bolt for kick starter for BMW R24-R27, R50-R69S and R50/5-R100 stainless steel	6,05 €	7,20 €
23b_071	1064	Grooved ball bearing gearbox outlet shaft for BMW R51/2-R68, front and rear and for BMW /5 - 4-gear- and 5-gearbox	7,98 €	9,50 €
23b_072	1242996	Intermediate gear box shaft for BMW R60/6-R100, 17,5°, until year of manufacture 09/1995 last version	357,48 €	425,40 €
23b_073	1064	Grooved ball bearing gearbox outlet shaft for BMW R51/2-R68, front and rear and for BMW /5 - 4-gear- and 5-gearbox	7,98 €	9,50 €
23b_074	35449	Bearing gearbox (roller bearing) input shaft, for BMW R50/5-R100, front	117,14 €	139,40 €
23b_075	2301778	Gearbox drive shaft for BMW R60/6-R100 from year of manufacture 09/1980, Ø 33,5mm, 17,5°	288,15 €	342,90 €
23b_075	1231516	Gearbox drive shaft for BMW R60/6-R100 from year of manufacture 09/1980, Ø 18mm	220,17 €	262,00 €
23b_075	2302327	Gearbox drive shaft for BMW R65GS-R100GS and R65-R100R from year of manufacture 03/1985, Ø 20mm Please give us the chassis number !!!	121,01 €	144,00 €
23b_075c	1241855	Gearbox drive shaft for BMW R60/6-R100 from year of manufacture 09/1980 until 03/1985 Ø=18	188,74 €	224,60 €
23b_076	1242991	Gear-wheel drive shaft for BMW R60/6-R100 "17,5° with ""X""-Mark"	91,85 €	109,30 €
23b_076	1231519	Gear-wheel drive shaft for BMW R60/6-R100 until year of manufacture 04/1982 "15°, WITHOUT ""X""-Mark"	53,28 €	63,40 €
23b_077	1233425	Drive thrust piece power-in shaft for BMW R45/R65, R50/5-R100, R80G/S, ST, 35mm	69,75 €	83,00 €
23b_079	31671	Kick starter gear for BMW R60/6-R100	141,60 €	168,50 €
23b_080	1231303	Pressure spring drive shaft for BMW R60/6-R100	9,75 €	11,60 €
23b_081a	1232086	Lock ring input shaft for BMW R60/6-R100	0,84 €	1,00 €
23b_082	1232062	Bushing input-shaft for BMW R60/6-R100	23,87 €	28,40 €
23b_083	1230452	Bearing cover ring for BMW-models from year of manufacture 09/1969 gearbox drive shaft	4,29 €	5,10 €
23b_084	42420	Radial seal ring, clutch thrust rod for BMW R60/6-R100	14,96 €	17,80 €
23b_085	1234215	Shifter fork for BMW R60/6-R100, 1./2. speed	154,79 €	184,20 €
23b_088	1234217	Shifter fork for BMW R60/6-R100, 3./4. speed	113,95 €	135,60 €
23b_089	1230075	Oil drip pan output shaft for BMW R50/5 and up	16,97 €	20,20 €
23b_090	9934100	Lock ring kickstarter and output shaft for BMW R50/5-R100	0,92 €	1,10 €
23b_090	1235006	Snap ring output shaft for BMW R50/5 and up	1,01 €	1,20 €
23b_092	6064	Bearing output shaft for BMW R60/6-R100, front and /5 4-gear box	21,51 €	25,60 €
23b_093c	99390	Gear-wheel 5th gear for BMW-models from year of manufacture 1982, +6% "17,5° with ""X""-Mark, ""long"" 5th gear"	157,82 €	187,80 €
23b_094	1231616	Washer output shaft for BMW R50/-R100 only for "Sport"-gearbox	3,03 €	3,60 €
23b_095	34886	Gear-wheel 3rd gear for BMW R60/6-R100 until year of manufacture 1982	124,03 €	147,60 €
23b_097	1231633	Washer output shaft for BMW 5-speed gearbox	3,78 €	4,50 €
23b_098	1338793	Power-gearbox output shaft for 5-speed gearbox	284,71 €	338,80 €
23b_103	1232299	Bushing for BMW R60/6-R100, 1st gear-wheel	39,24 €	46,70 €
23b_105	1231630	Shim for gearbox output shaft for BMW R50/5-R100 and 4 und 5. gear	4,54 €	5,40 €
23b_106	1064	Grooved ball bearing gearbox outlet shaft for BMW R51/2-R68, front and rear and for BMW /5 - 4-gear- and 5-gearbox	7,98 €	9,50 €
23b_107	1236746	Rubber boot gear shifter, years of manufacture 1970-1985	14,54 €	17,30 €
23b_113	45016	Shift lever rubber for BMW R24-R69S and R50/5-R75/5	1,60 €	1,90 €
23b_113	1232097	Shift lever rubber for BMW 5-speed-transmission	1,34 €	1,60 €
23b_114	2322402	Screw for mounting shift lever for BMW R50/5-R100 Allen® head, cined	0,84 €	1,00 €
23b_115	01391	Shift lever rod for BMW R60TIC-R100RT NEW VERSION: with intake for ball-shaped head	36,97 €	44,00 €
23b_117	1241593	Foot-Shift lever for BMW 5-speed gear box (transmitted) until year of manufacture 04/1985	47,73 €	56,80 €
23b_117a	2302383	Foot-Shift lever for BMW R65-R100RT from year of manufacture 04/1985	53,61 €	63,80 €
23b_118	1239023	Rocker switch for BMW R60/6-R80TIC until year of manufacture 09/1980 ONLY 5-gear-transmission!	123,36 €	146,80 €
23b_119	1241595	Shift lever bearing pin for BMW R60/7-R100 until year of manufacture 03/1985	17,65 €	21,00 €
23b_123	1461432	Shifting lever tenon from year of manufacture 1981 also for steering-damper for BMW R50/5 and up	2,86 €	3,40 €
23b_124	1150432	Dust cover for shifter rod for BMW R65GS-R100GS, R80R and R100R	1,76 €	2,10 €
23b_126	87611	Safety bow for ball pin for BMW R50/5-R100 steering damper and shifter gear	1,93 €	2,30 €



23b_129	2302380	O-ring shift lever for BMW R65-R100PD from year of manufacture 04/1985	0,50 €	0,60 €
23b_130	2302382	Bushing gear lever for BMW R65-R100PD from year of manufacture 04/1985	12,52 €	14,90 €
23b_130a	1238422	Needle bushing for shift lever / clutch lever for BMW R50/5-R100	10,34 €	12,30 €
23b_131	1338639	Shift lever bearing pin for BMW R65-R100GS from year of manufacture 04/1985	13,28 €	15,80 €
23b_18a	1355262	Gasket ring for neutral switch for BMW R60/6-R100	0,92 €	1,10 €
23b_24a	9963003	Gasket ring covering plate gear drive for R65GS-R80ST, years of manufacture 1980-1992	1,09 €	1,30 €

Group 26 Swingarm and drive shaft

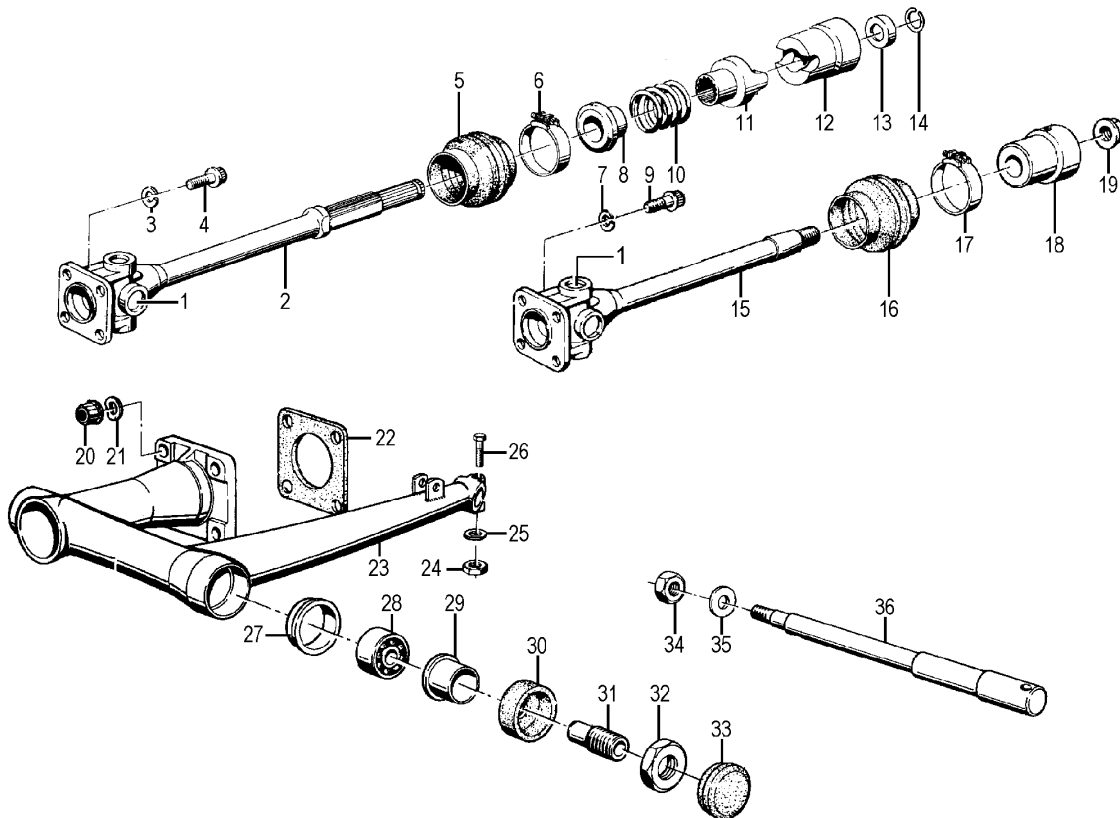

<u>Picture-No.</u>	<u>Article-No.</u>	<u>Description</u>	<u>Net</u>	<u>Gross</u>
26_001a	99921	U-joint for BMW R51/2-R68, R50-R69S and R50/5-R100 (all models)	39,50 €	47,00 €
26_001b	3034	Repair of universal joint, labour and u-joint	78,99 €	94,00 €
26_002	235972	Drive shaft for BMW R50/5, R60/5 and R75/5, short wheel base, until year of manufacture 02/1972 Cone shape 1:7, Orig. BMW NEW PART	224,20 €	266,80 €
26_002	1232560	Drive shaft for BMW R50/5-R100, long wheel base, years of manufacture 02/197-09/1978 Cone shape 1:7, without bell, Orig. BMW NEW PART	437,14 €	520,20 €
26_002d	1237180	Drive shaft for BMW R60/7-R100 until year of manufacture 09/1980	375,97 €	447,40 €
26_002e	1237500	Drive shaft for BMW R45 and R65 until year of manufacture 09/1980	346,22 €	412,00 €
26_002e	1242112	Drive shaft for BMW R45/R65, R80/7-R100RT, from year of manufacture 09/1980 and for BMW G65GS, R80G/S, R80ST (NOT for Paralever !)	376,55 €	448,10 €
26_003	98432	Lock washer A 8, Form B zincked	0,08 €	0,10 €
26_004	30414	Drive shaft, twelve-sided bolt for BMW R50-R69S and R50/5-R100RT until year of manufacture 09/1980	1,18 €	1,40 €
26_004	1242297	Drive shaft, twelve-sided bolt for BMW R45, R65 and R80/7-R100RT from year of manufacture 09/1980	2,02 €	2,40 €
26_005	1230304	Rubber boot Gearbox-swingarm for BMW R50/5-R100 and R45, R65	10,67 €	12,70 €
26_005b	1452504	Rubber boot swing arm/rear drive for BMW-models from year of manufacture 09/1984 and for BMW R100 from year of manufacture 09/1986	18,99 €	22,60 €
26_006	1458197	Clamp for boot between swing arm and rear drive for Paralever from year of manufacture 09/1987, small (90mm)	7,56 €	9,00 €
26_006a	2335120	Clamp for boot between swing arm and rear drive for Paralever from year of manufacture 09/1987, big (132mm)	7,73 €	9,20 €
26_014	1237189	Lock ring drive shaft bell for BMW R45/R65, R65GS-R80G/S and R60/7-R100RT, (not for Paralever)	1,93 €	2,30 €
26_017	30297	Clamp gearbox boot for BMW R50/5-R100, R65GS, R80G/S and R80ST zincked, Ø=83mm, original BMW	2,86 €	3,40 €
26_017a	39813	Clamp gearbox boot for BMW R50/5-R100, R65GS, R80G/S and R80ST stainless steal, Ø=83mm, original BMW	7,73 €	9,20 €
26_018b	1230305	Drive shaft bell for BMW R50/5, R60/5 and R75/5, 1:6 cone	43,19 €	51,40 €
26_018b	1232558	Drive shaft bell for BMW R50/5-R100RT, until year of manufacture 09/1978, 1:7 cone	85,29 €	101,50 €
26_019	30084	Drive shaft nut, M16 with bund	7,56 €	9,00 €
26_020	37789	Cylinder base 12-point nut for cardan coupling	2,44 €	2,90 €



26_021	22082	Spring washer B 8, DIN137A zincked	0,08 €	0,10 €
26_022	2311098	Gasket driveshaft for BMW R50/5-R100	1,60 €	1,90 €
26_026	98205	Screw M 8 x 35, hexagon with shaft e.g. for carburettor flansch for BMW R26/R27	0,25 €	0,30 €
26_027	39812	Grease stop washer swingarm for BMW R26, R27 and R50-R100, rear	4,96 €	5,90 €
26_028	13064	Wheel bearing for BMW R26, R27, R50/5-R100 and R45/R65 until year of manufacture 09/1984 and rocker arm for BMW R26, R27, R50-R69S and R50/5-R100, front and rear	16,39 €	19,50 €
26_028	0013064	Wheel bearing for BMW R26, R27 and R50/5-R100, +0,10 overmeasure and rocker arm for BMW R26, R27 and R50-R69S, front and rear	38,66 €	46,00 €
26_028	0013065	Wheel bearing for BMW R26, R27 and R50/5-R100, +0,15 overmeasure and rocker arm for BMW R26, R27 and R50-R69S, front and rear	40,59 €	48,30 €
26_028b	42618	Swingarm bearing capsuled for BMW-models from years of manufacture 01/1981 also for Monolever	34,20 €	40,70 €
26_029	00324	Thrust sleeve swingarm for BMW R26-R100	6,05 €	7,20 €
26_030	00331	Radial seal ring, swingarm for BMW R26, R27, R50-R69S and R50/5-R100 until 09/1980	3,28 €	3,90 €
26_030a	1236897	Gasket ring swing seal for BMW R45 dnd R65 until 01/1981, R80/R100 from year of manufacture 09/1980	3,03 €	3,60 €
26_031	30301	Bolt swingarm for BMW R50/5-R100	36,30 €	43,20 €
26_032	54174	Nut for rear swing arm bolt for BMW R26, R27, R50-R69S and R50/5-R100	5,04 €	6,00 €
26_033	1230296	Dust cap swingarm bearing for BMW R50/5-R100 Standard	1,76 €	2,10 €
26_033a	1230297	Dust cap swingarm bearing for BMW R50/5-R100 shiny	1,76 €	2,10 €
26_035	1232709	Washer for wheel axle for BMW R50/5-R100RS until year of manufacture 09/1980, rear, large stainless steel	5,97 €	7,10 €
26_036	35830	Wheel axle for BMW R100S, R100RT, R100CS and R100RS until year of manufacture 09/1984, rear disk brake	60,59 €	72,10 €
26_036a	30303	Wheel axle for BMW R45/R65 and R50/5-R100 until year of manufacture 09/1984, rear stainless steel polished, drum break	43,61 €	51,90 €
26_036a	1230303	Wheel axle for BMW R45/R65 and R50/5-R100 until year of manufacture 09/1984, rear drum break	70,59 €	84,00 €
26_999	1237184	Spring for drive thrust piece for BMW R45/R65, R80/7-R100RT from year of manufacture 09/1980 and for BMW R65GS, R80G/S, R80ST (NOT for paralever!)	19,08 €	22,70 €



Group 31 Fork

1969-1976, 1977-1978er R60,75,80 und 80RT

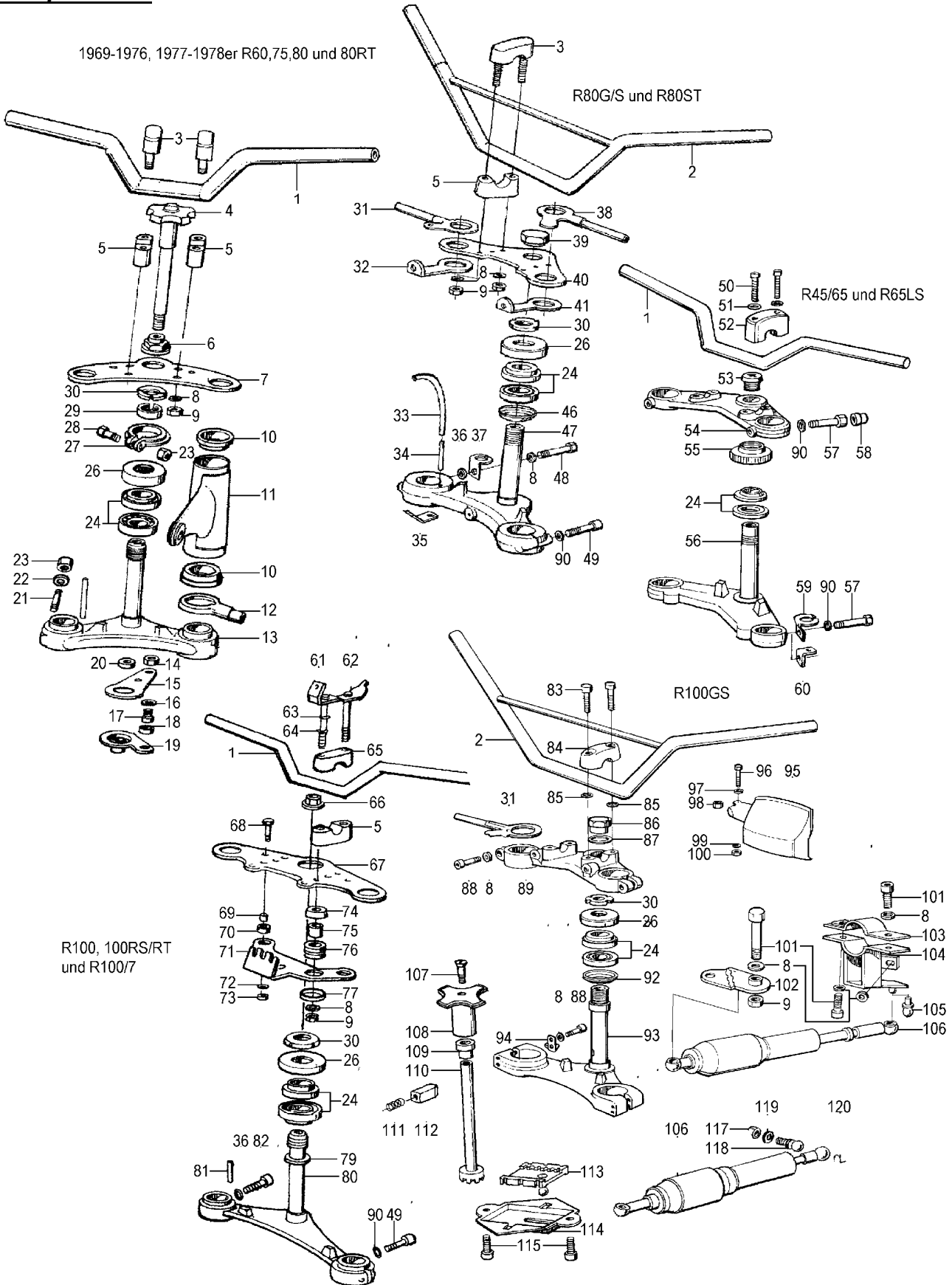

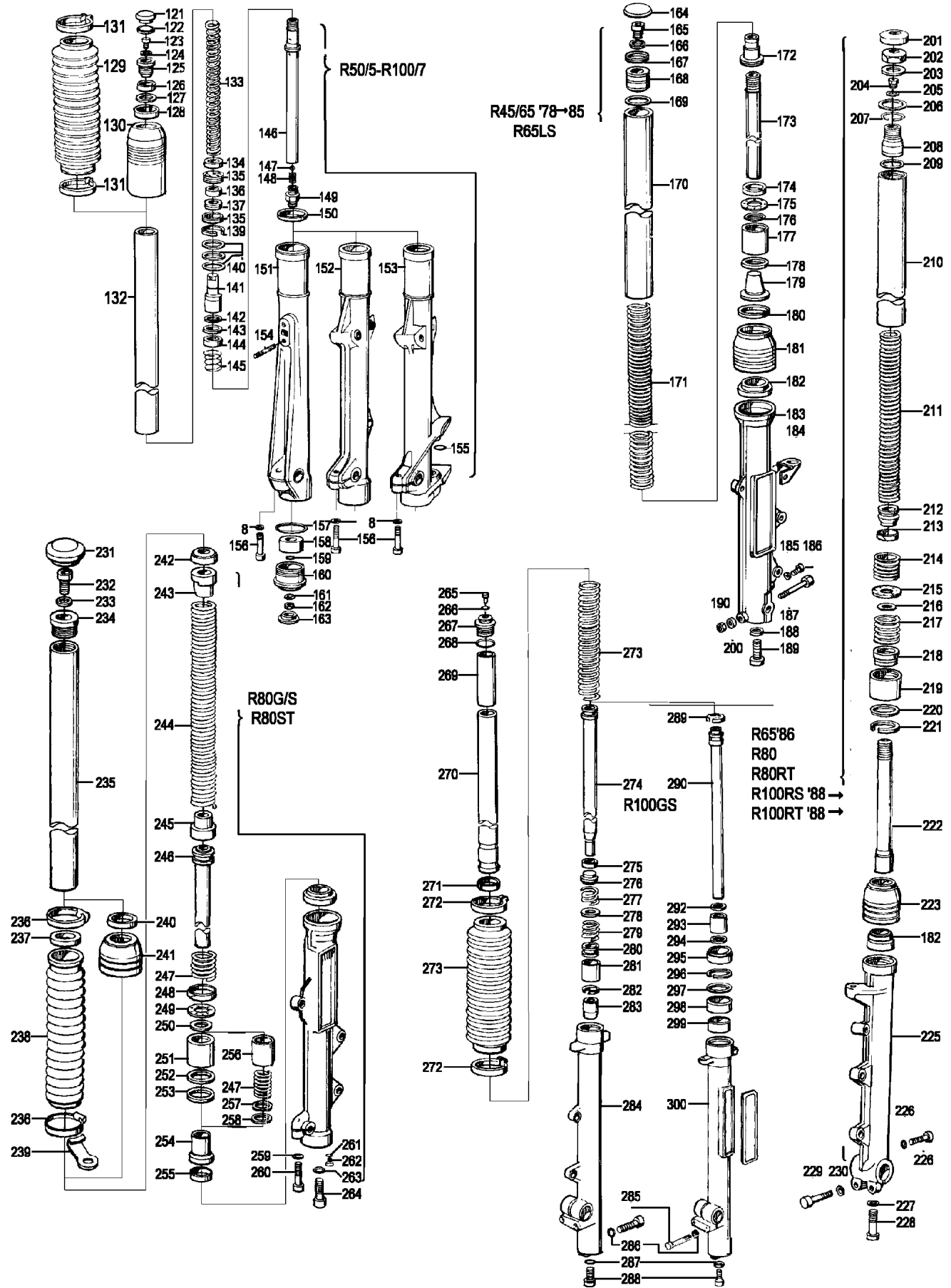

Picture-No. Article-No. Description

31_0	22083	Spring washer B10, DIN137A zincked
31_000	2311639	Nut for top fork yoke for BMW R80R/R100R, R80GS/R100GS and R80GS Basic
31_000	2312714	O-ring fork oil filler screw for BMW R80R and R100R
31_000	2312848	Fork seal ring (piston ring) for BMW R80R and R100R

Net	Gross
0,17 €	0,20 €
8,24 €	9,80 €
0,59 €	0,70 €
3,11 €	3,70 €



31_000	238217	Steering damper return spring for BMW R60/7-R100 also as clutch release fork spring for models until year of manufacture 1973	3,45 €	4,10 €
31_000	1458474	Distance washer fork seal for BMW Models from year of manufacture 09/1984	1,34 €	1,60 €
31_000	1237213	Fork felt for BMW R45, R65, R80 and R100 from year of manufacture 1978	1,34 €	1,60 €
31_000	1458065	Fork boot for BMW R80GS, R100GS years of manufacture 1991-1995 and R80GS Basic	15,71 €	18,70 €
31_000	3060	Fork oil ATF-A, 1 Liter	6,55 €	7,80 €
31_000	1452138	Washer fork for BMW R65RT and R80RT until year of manufacture 10/1985	0,84 €	1,00 €
31_000	1240504	Fork for MW R50/5-R75/5 used	618,07 €	735,50 €
31_000	1457133	Cover cap for fork stabilisator screw for BMW R65/R80 from 1985	1,51 €	1,80 €
31_000	1356802	Side reflector with safety carrier, fork for BMW R60/6-R100	14,62 €	17,40 €
31_000	1236900	Cover cap for front fender screw for BMW R45, R65 from year of manufacture 09/1984 and R80ST	2,18 €	2,60 €
31_000	1232925	Handlebar clamping support SET for BMW R50/5, R60/5 and R75/5 polished (1x upper part + 1x lower part) REMNANTS	86,55 €	103,00 €
31_001	94052	Handlebar for side car use, universal, flat 750mm wide, Fehling	45,29 €	53,90 €
31_001	72002	Handlebar (touring) medium high 95mm high, 670mm wide	28,57 €	34,00 €
31_001	5052	Handlebar half-high, similar to BMW R50/5, R60/5 and R75/5 145mm high, 765mm wide, Fehling, US-Version	46,81 €	55,70 €
31_001a	72189	Handlebar for BMW R50/5-R100/7, original shape, flat	28,99 €	34,50 €
31_001c	03043	Handlebar for BMW RT-Models and R45/R65, high Fehling	43,11 €	51,30 €
31_001h	3062	Handlebar, LN A 200mm high, 800mm wide, Fehling, REMNANTS	31,09 €	37,00 €
31_002	72036	Handlebar for BMW R50-R69S, half-high with cross bar 160mm high, 750mm wide, US-Version	44,03 €	52,40 €
31_003	00391	Handlebar clamping support for BMW R50/5, R60/5 and R75/5, upper	31,93 €	38,00 €
31_004	30467	Steering damper knob for BMW R50/5, R60/5 and R75/5	48,74 €	58,00 €
31_005	32926	Handlebar clamping support for BMW R90S-R100RT, lower black	53,03 €	63,10 €
31_006a	30478	Cap nut fork top for BMW R50/5-R100RT with hole	16,30 €	19,40 €
31_006b	1235429	Cap nut fork top for BMW R65-R100 until year of manufacture 09/1984, without hole	22,44 €	26,70 €
31_007	1232511	Top fork yoke for BMW R50/5-R90/6	80,76 €	96,10 €
31_007a	1240075	Top fork yoke for BMW R60/7-R100, from year of manufacture 09/1977	29,41 €	35,00 €
31_008	98414	Washer M 8, DIN125, Form A cinced	0,08 €	0,10 €
31_010	2000385	Fork rubber ring for BMW R50/5-R100 and R65, lower until year of manufacture 1995	4,12 €	4,90 €
31_010	1230696	Fork rubber ring for BMW R50/5-R100, upper, 4,0mm until year of manufacture 08/1984	3,53 €	4,20 €
31_010bb	1452141	Fork rubber ring for BMW R65, R100R, R80 and R80R, upper from year of manufacture 09/1984	2,18 €	2,60 €
31_011a	1231014	Headlight ear for BMW R50/5, R60/5 and R75/5, left side	62,18 €	74,00 €
31_011b	1231018	Headlight ear for BMW R50/5, R60/5 and R75/5, right side	62,18 €	74,00 €
31_011e	2307385	Headlight bracket cover for BMW R80R-R100R, left side primed	40,17 €	47,80 €
31_011f	2307386	Headlight bracket cover for BMW R80R-R100R, right side primed	31,93 €	38,00 €
31_012a	1233941	Indicator light holder for BMW R50/5-R100/7, front, chromed	33,87 €	40,30 €
31_013a	1230577	Lower fork yoke for BMW R50/5-R75/5	302,86 €	360,40 €
31_013b	1233956	Lower fork yoke for BMW R60/6-R100 until year of manufacture 09/1984	261,43 €	311,10 €
31_015	30471	Steering damper resistance plate for BMW R50/5, R60/5 and R75/5	13,95 €	16,60 €
31_017	98165	Screw M 6 x 16, cylinder-head Allen® key	0,17 €	0,20 €
31_024	9985070	Steering head bearing set for BMW R50/5-R100R	40,59 €	48,30 €
31_026	00312	Dust cap steering head for R50/5-R100, top	26,89 €	32,00 €
31_030	32343	Lock nut fork top for BMW R65-R100 from year of manufacture 09/1984	23,19 €	27,60 €
31_031	1242232	Indicator light holder for BMW R80G/S, front, right side	25,88 €	30,80 €
31_034	41470	Clamping pin for lower fork yoke and for valve cover for BMW R50/5-R100 R65GS, R80G/S and R65 from year of manufacture 09/1984	0,84 €	1,00 €
31_038	1242231	Indicator light holder for BMW R80G/S, front, left side	25,88 €	30,80 €
31_046	34509	Dust cap steering head for R45/R65, R50/5-R100, bottom	5,97 €	7,10 €
31_047	2311637	Lower fork yoke for BMW R80-R100GS, PD, Basic	212,10 €	252,40 €
31_053	1237243	Screw for top fork yoke for BMW R45/R65 until year of manufacture 09/1984	26,22 €	31,20 €
31_054	1237191	Top fork yoke for BMW R45 and R65	88,66 €	105,50 €
31_054a	1235573	Headlight ear-indicator holder unit for BMW R45/R65 and R80ST front plate	110,34 €	131,30 €
31_059	1237255	Brake hose holder for BMW R45 and R65, upper fork yoke	12,27 €	14,60 €
31_066	1242262	Grooved nut fork top for BMW R50/5-R100	9,33 €	11,10 €
31_069	1232242	Bushing gauge-unit holder for BMW R60/6-R100, small	1,09 €	1,30 €
31_070	7670749	Grommet instruments-holder for BMW R60/6-R100, small	1,93 €	2,30 €
31_071	1232240	Instrument holder for BMW R60/6-R100S	25,63 €	30,50 €
31_074	1232243	Cap for upper fork guide for BMW R60/6-R100RT	1,34 €	1,60 €
31_075	1232241	Bushing gauge-unit holder for BMW R60/6-R100, large	4,79 €	5,70 €
31_076	1232245	Grommet instruments-holder for BMW R60/6-R100, large	2,02 €	2,40 €
31_079	34509	Dust cap steering head for R45/R65, R50/5-R100, bottom	5,97 €	7,10 €



31_089	2311682	Top fork yoke for BMW R80-R100GS, PD, Basic	254,12 €	302,40 €
31_090	98420	Washer M10, DIN125, Form A cined	0,08 €	0,10 €
31_093	2311637	Lower fork yoke for BMW R80-R100GS, PD, Basic	212,10 €	252,40 €
31_095a	2315713	Hand protector cover for BMW R80GS and R100GS from year of manufacture 1991, right side	3,95 €	4,70 €
31_095b	2315711	Hand protector for BMW R80GS-R100PD from year of manufacture 1991, left side	13,78 €	16,40 €
31_095d	1234359	Hand protector police fairing for BMW-models, right side	39,16 €	46,60 €
31_095e	2315712	Hand protector for BMW R80GS-R100PD from year of manufacture 1991, right side	13,78 €	16,40 €
31_1	63073	Gasket ring toolbox screw, M10x14x1.5	0,25 €	0,30 €
31_105	1461432	Shifting lever tenon from year of manufacture 1981 also for steering-damper for BMW R50/5 and up	2,86 €	3,40 €
31_106	32361	Steering damper hydraulic for BMW R50/5-R100	65,21 €	77,60 €
31_107	9928103	Screw for Steering damper knob for BMW R60/6-R100	1,09 €	1,30 €
31_108	36892	Steering damper hand wheel R60/6-R100	9,92 €	11,80 €
31_109	32556	Bushing steering damper for BMW R60/6-R100	7,73 €	9,20 €
31_110	32275	Steering damper cogwheel for BMW R60/6-R100	10,59 €	12,60 €
31_113	1232274	Steering damper slide for BMW R60/6-R100	13,61 €	16,20 €
31_114	1232270	Steering damper housing for BMW R60/6-R100	38,07 €	45,30 €
31_115	98137	Screw M 5 x 16, cylinder-head Allen® key	0,17 €	0,20 €
31_118	1237285	Steering damper bolt for BMW R45, R65 and R65LS	5,21 €	6,20 €
31_120	87611	Safety bow for ball pin for BMW R50/5-R100 steering damper and shifter gear	1,93 €	2,30 €
31_121	1234399	Front fork cap for BMW R50/5-R100/7 and R100S until year of manufacture 09/1977	16,47 €	19,60 €
31_121	1237858	Pin wrench for fork cap for BMW /5 and up until year of manufacture 09/1977 original BMW	17,65 €	21,00 €
31_122	33343	Gasket ring fork for BMW R25, R25/2 and from R50/5, upper cap	1,51 €	1,80 €
31_123	9919662	Fork oil fill screw for BMW R60/6-R100	2,35 €	2,80 €
31_124	9963041	Gasket ring for small fork seal screw for BMW R50/5-R100 until year of manufacture 09/1977 and fork from BMW R50/5 and up, bottom, small	0,25 €	0,30 €
31_125	1238904	Fork mount piece for BMW R60/7-R100 till year of manufacture 09/80	36,97 €	44,00 €
31_126	2000399	Fork spacer for BMW R50/5, R60/5 and R75/5, pre-tension	2,35 €	2,80 €
31_127	40179	Washer fork yoke top for BMW R50/5 and up	5,80 €	6,90 €
31_128	1233038	Fork felt for BMW R90S, R100S/RT/T/S, /7, R80 until year of manufacture 09/1980	1,76 €	2,10 €
31_129a	34908	Rubber boot fork for BMW R50/5-R100/7 with 13 ribs	15,63 €	18,60 €
31_129b	1234908	Rubber boot fork for BMW R50/5-R100/7 with 11 ribs	14,71 €	17,50 €
31_130	34396	Fork boot for BMW R90S and R60/7-R100RT until year of manufacture 09/1980	23,87 €	28,40 €
31_131	61026	Clamp fork boot for BMW R50/5-R100/7 (clamp with screw)	1,34 €	1,60 €
31_131	9061026	Clamp air tube for BMW R50/5, R60/5, R60/6 and R60/7 (clamp with screw)	1,34 €	1,60 €
31_131	9161026	Clamp air tube rubber for BMW R75/5, R75/6 and R90/6 (clamp with screw)	1,34 €	1,60 €
31_132	41655	Fork tube for BMW R80, R80G/S and R100 years of manufacture 09/1980-09/1984	155,71 €	185,30 €
31_132a	00376	Fork tube for BMW R50/5-R100 until year of manufacture 09/1980	166,05 €	197,60 €
31_132e	1454814	Fork tube for BMW R65-R100RT from year of manufacture 1985	155,71 €	185,30 €
31_133b	1231358	Fork spring for BMW R50/5-R100 until year of manufacture 09/1980, normal model	41,76 €	49,70 €
31_133b	32018	Front fork spring set for BMW R50/5-R100 until year of manufacture 09/1984, progressive	51,18 €	60,90 €
31_133b	1232017	Fork spring for BMW R50/5-R100RT until year of manufacture 09/1984, heavy duty original BMW	47,06 €	56,00 €
31_133b	1241657	Fork spring for BMW R80-R100RT years of manufacture 09/1980-09/1984 and for BMW R65GS, R80GS years of manufacture 1981-1992, original BMW	26,89 €	32,00 €
31_134	2000384	Fork stop bushing for BMW R50/5-R100, until year of manufacture 08/1980	3,28 €	3,90 €
31_135	1232046	Fork threaded ring for BMW R50/5-R100 until year of manufacture 09/1980	21,60 €	25,70 €
31_136	1232045	Fork damper ring for BMW R50/5-R100 until year of manufacture 08/1980	11,18 €	13,30 €
31_137	1234506	Fork damper ring for BMW R50/5-R100 until year of manufacture 08/1980 for harder springs	8,57 €	10,20 €
31_139	9934650	Lock ring fork for BMW R50/5-R100 until year of manufacture 09/1980	1,51 €	1,80 €
31_140	1232059	Front fork inner wiper ring for BMW R50/5-R100 until year of manufacture 09/1980	2,77 €	3,30 €
31_141	1232054	Spring retainer, lower R50/5-R100 ->09/80	38,91 €	46,30 €
31_142	1232763	Fork inner plastic washer for BMW R50/5-R100	6,30 €	7,50 €
31_143	1232058	Bushing fork for BMW R50/5-R75/5	7,73 €	9,20 €
31_145	1232057	Thrust spring fork, damper/tube for BMW models from year of manufacture 09/1969	1,93 €	2,30 €
31_147	86280	Ball for fork bolt for BMW R50/5, R60/5 and R75/5	0,50 €	0,60 €
31_148	32061	Spring for fork bolt for BMW R50/5-R100	1,68 €	2,00 €
31_149	32060	Fork bolt, lower, for BMW R50/5-R100	12,52 €	14,90 €
31_150	230001	Radial seal ring, fork for BMW R50/5-R100RS and R45/R65 until year of manufacture 08/1984 and R65GS-R80ST years of manufacture 09/1980-09/1987 (Monolever)	5,88 €	7,00 €
31_151	2000378	Fork sliding tube for BMW R50/5, R60/5 and R75/5, right side	191,51 €	227,90 €



31_151	2000377	Fork sliding tube for BMW R50/5, R60/5 and R75/5, left side	191,51 €	227,90 €
31_152	1232297	Fork sliding tube for BMW R60/6 until year of manufacture 09/1974, right side for 14mm axle	186,05 €	221,40 €
31_153	1232255	Fork sliding tube for BMW R60/6-R90S until year of manufacture 09/1974, right side for 14mm axle	213,28 €	253,80 €
31_153a	1232476	Fork sliding tube for BMW R60/6-R90S until year of manufacture 09/1974, left side for 14mm axle	213,28 €	253,80 €
31_153c	1233509	Fork sliding tube for BMW R75/6-R100RT years 09/1974-09/1980, left side for 17mm axle	298,57 €	355,30 €
31_154	98562	Stud bolt engine / gearbox for BMW R50-R69S, carburettor flange R25-R69S and fork /5, M8x25	3,45 €	4,10 €
31_155	1231483	Radial seal ring, skid pipe / bolt brake caliper ATE for BMW R60/6-R100/7 and R80-R100RT until year of manufacture 09/1980	9,75 €	11,60 €
31_156	98204	Screw M 8x35, allen-head for BMW R50/5-R100 cylinder-head screw, hexagon socket	0,50 €	0,60 €
31_156	2322411	Fork oil drain screw M 5 from BMW R60/7 and up	0,25 €	0,30 €
31_157a	1232426	Gasket ring fork for BMW R50/5-R75/5, lower, large	1,51 €	1,80 €
31_157b	1232369	Gasket ring fork for BMW R60/6-R100 until year of manufacture 09/1984, lower, large also gasket ring exhaust pipe for BMW R35	2,18 €	2,60 €
31_157c	9963010	Gasket ring fork from BMW R60/7, lower, small	1,18 €	1,40 €
31_158a	1230751	Fork bumper ring for BMW R50/5, R60/5 and R75/5	4,79 €	5,70 €
31_158b	1231314	Fork bumper ring for BMW R60/6-R100 until year of manufacture 08/1980	6,89 €	8,20 €
31_159	9963041	Gasket ring for small fork seal screw for BMW R50/5-R100 until year of manufacture 09/1977 and fork from BMW R50/5 and up, bottom, small	0,25 €	0,30 €
31_160	2000380	Lock screw fork for BMW R50/5, R60/5 and R75/5, bottom	41,51 €	49,40 €
31_160	1231506	Lock screw fork for BMW R60/6-R100, bottom	41,51 €	49,40 €
31_160	2000382	Lock screw fork for BMW R50/5-R75/5, bottom used	21,60 €	25,70 €
31_161	54140	Gasket ring fork BMW R25/3, R51/2-R68 and R50/5-R75/5 for shock tube, low	0,50 €	0,60 €
31_162	22093	Nut M 8 x 1 zincked	0,25 €	0,30 €
31_163	2000381	Front fork cap for BMW R50/5-R100, lower, until year of manufacture 08/1980	2,77 €	3,30 €
31_166	9919662	Fork oil fill screw for BMW R60/6-R100	2,35 €	2,80 €
31_167	9934645	Lock ring fork for BMW R45/R65 until year of manufacture 09/1980 and for BMW R65GS-R80ST, R80, R100 from year of manufacture 11/1982	0,84 €	1,00 €
31_169	37245	O-ring upper spring retainer for BMW R45 and R65	1,09 €	1,30 €
31_170	41657	Fork tube for BMW R45 and R65	128,82 €	153,30 €
31_171	32021	Front fork spring set for BMW R45, R65 and R80ST until year of manufacture 09/1984, progressive	51,93 €	61,80 €
31_174	1237215	Fork bumper ring for BMW R45 and R65 until year of manufacture 09/1984	2,52 €	3,00 €
31_178	1242646	Lock ring fork for BMW R45/R65 from year of manufacture 09/1980 and for BMW R80/7-R100RT, R80G/S, ST, years 09/1980-11/1982	0,84 €	1,00 €
31_181	1237205	Fork boot for BMW R45/R65, R80-R100RT and R80ST years of manufacture 09/1980-09/1984	7,90 €	9,40 €
31_182	10199	Radial seal ring, fork for BMW R65-R100RT from year of manufacture 1984	11,60 €	13,80 €
31_182	1241737	Fork spacer Typ 56 all, Typ 54 from year of manufacture 11/1982 Typ 57 from year of manufacture 09/1980	14,37 €	17,10 €
31_182	230001	Radial seal ring, fork for BMW R50/5-R100RS and R45/R65 until year of manufacture 08/1984 and R65GS-R80ST years of manufacture 09/1980-09/1987 (Monolever)	5,88 €	7,00 €
31_201	1454815	Front fork cap for BMW R65-R80RT from year 1985, R100 until 1987, top	2,02 €	2,40 €
31_201	1238909	Front fork cap plastic for BMW R60/7-R100RT, top, from 09/1977-1995	6,47 €	7,70 €
31_209	1454962	O-ring fork for BMW R65-R80RT from year of manufacture 09/1984 and for BMW R100 from year of manufacture 09/1986	1,68 €	2,00 €
31_211	32020	Fork spring for BMW R65-R100 from year of manufacture 1985, progressive	21,26 €	25,30 €
31_213	1452013	Fork guide plastic for BMW R65, R80 and R100 from year of manufacture 09/1984	5,38 €	6,40 €
31_218	2301886	Fork spring sleeve for BMW R80, R100 and R65GS from year of manufacture 11/1982	2,35 €	2,80 €
31_223	1454392	Fork boot for BMW models years of manufacture 09/1984-09/1996	19,58 €	23,30 €
31_228	9913408	Fork oil drain screw for BMW R65, R80 from year 09/1984 and R100 from year 09/1986	0,92 €	1,10 €
31_232	9919112	Fork oil fill screw for BMW R65, R80GS, ST from year of manufacture 1980, RT from year 1985 R100 from year of manufacture 1987	0,84 €	1,00 €
31_237	1241669	Fork rubber ring for BMW R65GS and R80GS	6,55 €	7,80 €
31_238a	1241666	Rubber boot fork for BMW R80G/S and R65GS	15,38 €	18,30 €
31_238b	1311077	Rubber boot fork for BMW R80GS and R100GS from year of manufacture 09/1988	18,15 €	21,60 €
31_243	2301724	Front fork support bearing for BMW R65GS, R80G/S and R80-R100 from year of manufacture 09/1980	14,62 €	17,40 €
31_244	1231358	Fork spring for BMW R50/5-R100 until year of manufacture 09/1980, normal model	41,76 €	49,70 €
31_244	32018	Front fork spring set for BMW R50/5-R100 until year of manufacture 09/1984, progressive	51,18 €	60,90 €
31_244	1232017	Fork spring for BMW R50/5-R100RT until year of manufacture 09/1984, heavy duty original BMW	47,06 €	56,00 €
31_244	1241657	Fork spring for BMW R80-R100RT years of manufacture 09/1980-09/1984 and for BMW R65GS, R80GS years of manufacture 1981-1992, original BMW	26,89 €	32,00 €



31_244a	3142510	Front fork spring set for BMW R80GS and R100GS, progressive from year of manufacture 09/1987	51,09 €	60,80 €
31_248	1241649	Fork guide plastic for BMW-models from year of manufacture 09/1980-1984 DELIVERY TIME: at the earliest of July 2019	21,09 €	25,10 €
31_250	1242645	Valve disc for fork for BMW models years of manufacture 1976-1984	0,92 €	1,10 €
31_270	1457853	Fork tube for BMW R80GS, R100GS and R80GS Basic	291,43 €	346,80 €
31_273a	1458220	Rubber boot fork for BMW R80GS, R100GS/PD from year 1987-08/1989	31,60 €	37,60 €
31_273b	1311077	Rubber boot fork for BMW R80GS and R100GS from year of manufacture 09/1988	18,15 €	21,60 €
31_298	1458064	Radial seal ring, fork for BMW R80GS, R100GS and R80GS Basic from year of manufacture 09/1990	8,32 €	9,90 €
31_301	1244529	Side reflector yellow, fork for BMW R45-R100 and for touring bags until year of manufacture 09/1984	6,55 €	7,80 €
31_999	2314034	Screw for top fork yoke for BMW R80R and R100R, Mystic	12,86 €	15,30 €
31_999	50127	Radial seal ring, fork for BMW K75-K100 REMNANTS	7,82 €	9,30 €
31_999	2312838	Radial seal ring, fork / skid pipe for BMW R80R and R100R years of manufacture 1991-1995	9,24 €	11,00 €
31_999	2312831	Fork tube for BMW R80R, R100R/Mystik years of manufacture 1991-1995	190,59 €	226,80 €



Group 32 Steering and handlebar

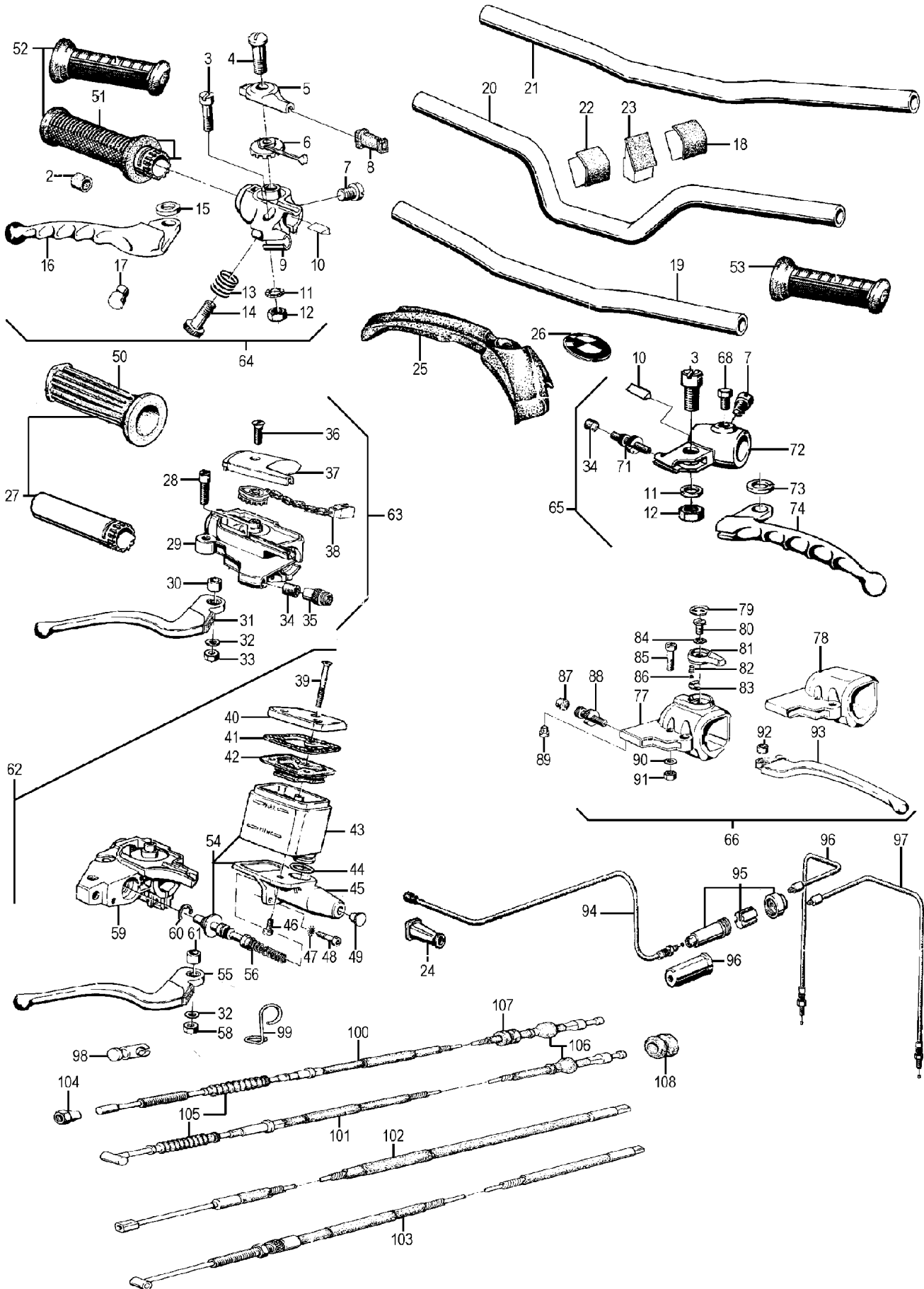

<u>Picture-No.</u>	<u>Article-No.</u>	<u>Description</u>	<u>Net</u>	<u>Gross</u>
32_0	1451749	Clutch/brake lever bolt for BMW R80-R100, from year of manufacture 09/1990 black	3,03 €	3,60 €



32_000	1451734	Throttle control housing for BMW R80-R100PD, from year of manufacture 09/1990	47,73 €	56,80 €
32_000	1236886	Cover cap for extra switch for BMW R45-R100	2,86 €	3,40 €
32_000	1237001	Cover cap for additional switch for BMW R60/7-R100	1,51 €	1,80 €
32_000	1236871	Handlebars impact plate R60/7-R100	319,33 €	380,00 €
32_000	1459318	Cover cap for impact plate for K-Model and R1100	1,01 €	1,20 €
32_000	1452460	Handlebars impact plate R65, R80 09/85->	15,55 €	18,50 €
32_000	1242932	Cover cap for additional switch for BMW R45-R65RT SF, R100RT/RS, R80, R80ST/RT	4,54 €	5,40 €
32_004	72259	Screw for throttle cover for BMW R26, R27, R50-R69S and R50/5-R100 until year of manufacture 1981 stainless steel polished	6,97 €	8,30 €
32_005b	1233306	Throttle control cover for BMW R50/5-R90S, years of manufacture 09/1972-08/1974, long	22,35 €	26,60 €
32_006	1232463	Throttle cam for BMW R50/5-R90S until year of manufacture 09/1974 brass	47,06 €	56,00 €
32_007a	72219	Clamp screw, control housing for BMW R26, R27, R50-R69S and R50/5-R75/5	0,50 €	0,60 €
32_007b	9900311	Clamp screw, control housing for BMW models from year of manufacture 09/1975	0,50 €	0,60 €
32_008	30037	Grommet for throttle cabel on handle bar, 2 cables for BMW R50/5-R100RT	2,77 €	3,30 €
32_009a	1232664	Throttle control housing for BMW R50/5-R90S, years of manufacture 09/1972 - 08/1974 original BMW	64,45 €	76,70 €
32_010	72223	Wedge for Magura throttle/clutch assy for BMW R26, R27, R50-R69S and R50/5-R90S	4,29 €	5,10 €
32_011	1230871	Spring washer for clutch/- brake lever	0,67 €	0,80 €
32_012	38382	Nut for brake / clutch lever bolt	0,59 €	0,70 €
32_014	1230874	Locking screw for throttle control for BMW R50/5-R100 (including spring)	8,57 €	10,20 €
32_016	1233350	Brake lever for BMW R50/5-R90S, until year of manufacture 08/1974	39,92 €	47,50 €
32_017	11440	Nipple adaptor for BMW R26, R27, R50-R69S and for BMW R50/5-R90S on lever until year of manufacture 09/1975	6,47 €	7,70 €
32_020	5052	Handlebar half-high, similar to BMW R50/5, R60/5 and R75/5 145mm high, 765mm wide, Fehling, US-Version	46,81 €	55,70 €
32_020	3063	Handlebar, LN B 250mm high, 830mm wide, Fehling	49,08 €	58,40 €
32_020	2303272	Handlebar for BMW R65GS and R80G/S-R100GS black	154,29 €	183,60 €
32_021	72189	Handlebar for BMW R50/5-R100/7, original shape, flat	28,99 €	34,50 €
32_024	42495	Grommet for throttle cabel on handle bar, 1 cable, for BMW R26 and R27	3,78 €	4,50 €
32_025	35611	Handle impact plate R100RS	86,47 €	102,90 €
32_026	1238280	Emblem baffle plate handlebar for BMW-Models from year of manufacture 1976 until 1984	7,48 €	8,90 €
32_027	1454129	Throttle twist tube for BMW R60/6-R100, R65GS-R100GS, R45/R65 from year of manufacture 09/1974	32,27 €	38,40 €
32_028	1451749	Clutch/brake lever bolt for BMW R80-R100, from year of manufacture 09/1990 black	3,03 €	3,60 €
32_031a	1234850	Brake lever for BMW R60/6-R100, years of manufacture 09/1974-08/1980	48,57 €	57,80 €
32_031b	1238384	Brake lever for BMW R45 and R65, until year of manufacture 08/1980	31,09 €	37,00 €
32_032	1230871	Spring washer for clutch/- brake lever	0,67 €	0,80 €
32_034	1231610	Felt for cables from R50/5 and up	1,93 €	2,30 €
32_036	1454245	Screw for throttle cover for BMW models from year of manufacture 09/1981 REMNANTS	2,18 €	2,60 €
32_037c	1242561	Throttle control cover for BMW R80 and R100, new cam, 1 cable and for BMW R45, R65 from year of manufacture 09/1980	22,35 €	26,60 €
32_038	1232463	Throttle cam for BMW R50/5-R90S until year of manufacture 09/1974 brass	47,06 €	56,00 €
32_038a	1233535	Throttle cam for BMW R60/6-R100, years of manufacture 09/1974-09/1980 33mm stroke, 2 cables	21,09 €	25,10 €
32_038b	1457036	Throttle cam for BMW R80GS-K100 from year of manufacture 09/1990 38mm stroke, 1 cable	15,55 €	18,50 €
32_038c	1233536	Throttle cam for BMW R90S, R100S, R100RT and R100RS, years of manufacture 09/1974-09/1980 40mm stroke, 2 cables	18,66 €	22,20 €
32_038d	1457038	Throttle cam for BMW R80, R80GS and R65-R100 from year of manufacture 09/1985 35mm stroke, 2 cables	23,19 €	27,60 €
32_038e	1457080	Throttle cam for BMW R80, R45, R65 years of manufacture 09/1980-09/1984 and for BMW R65G/S-R80ST from year of manufacture 09/1984, 35mm stroke, 1 cable	15,55 €	18,50 €
32_038f	1457081	Throttle cam for BMW R100 from year of manufacture 09/1980 42mm stroke, 1-cable and for BMW R80 from year of manufacture 1985	18,15 €	21,60 €
32_038g	1458092	Throttle cam for BMW R80 and R100GS, years of manufacture 09/1987-08/1990 42mm stroke, 2 cables	21,09 €	25,10 €
32_038h	1238379	Throttle cam for BMW R45 and R65, years of manufacture 09/1978-09/1985 33mm stroke, 2 cables	21,09 €	25,10 €
32_039a	9928128	Brake fluid container screw for BMW R80R/R100R, R80GS Basic and R80GS/R100GS from year of manufacture 09/1990, short	4,29 €	5,10 €
32_039b	9942544	Break fluid container screw from year of manufacture 09/1976, long and for BMW R45 and R65 from year of manufacture 09/1980	3,45 €	4,10 €
32_039c	2311143	Brake fluid container screw for BMW R45 und R65 until year of manufacture 09/1980 REMNANTS	2,52 €	3,00 €
32_040a	1454945	Brake fluid container cover for BMW R80/7-R100 and R45 and R65 from year of manufacture 09/1980	16,13 €	19,20 €
32_040b	1454944	Brake fluid container cover for BMW R80R/R100R, R80GS Basic and R80GS/R100GS from year of manufacture 09/1990	9,16 €	10,90 €



32_040c	1238389	Brake fluid container cover for BMW R45 and R65 until year of manufacture 09/1980	9,50 €	11,30 €
32_042a	1242547	Brake fluid container boot & washer for BMW R80/7-R100 from year of manufacture 09/1976 and for BMW R45 and R65 from year of manufacture 09/1980	10,76 €	12,80 €
32_042b	1451742	Brake fluid container boot & washer for BMW R80R/R100R and R80G/S and R100GS from year of manufacture 09/1990	7,82 €	9,30 €
32_042c	1238387	Brake fluid container boot & washer for BMW R45 and R65 until year of manufacture 08/1980	8,24 €	9,80 €
32_043	1242623	Brake fluid container on throttle-control for BMW R45/R65+R80/7-R100, from year of manufacture 1976	12,94 €	15,40 €
32_044	42624	O-ring brake box (gas grip)	3,03 €	3,60 €
32_050	720852	Handle bar rubber for BMW R60/7-R100, in-house production, square, pair	11,18 €	13,30 €
32_050a	2300388	Heating grip R65-R100, RH, Original BMW	68,32 €	81,30 €
32_051	1233307	Throttle twist tube for BMW R50/5-R90S until year of manufacture 08/1974 with handle rubber	32,86 €	39,10 €
32_051a	72153	Throttle twist tube for BMW R26, R27 and R50-R69S and for BMW R50/5-R90S until year of manufacture 08/1974, steel	26,64 €	31,70 €
32_052	30407	Handle bar rubber for BMW R24-R90S, in-house production, round, left side	4,79 €	5,70 €
32_052	37812	Handle bar rubber for BMW R60/7-R100, in-house production, square, right side	5,63 €	6,70 €
32_052	30868	Handle bar rubber for BMW R24-R90S, in-house production, round, right side	4,79 €	5,70 €
32_052a	19152	Handle bar rubber for BMW R24-R90S, in-house production, round, pair	9,16 €	10,90 €
32_052b	720850	Handle bar rubber for BMW R24-R90S, Magura, round, pair	17,23 €	20,50 €
32_053	37811	Handle bar rubber for BMW R60/7-R100, in-house production, square, left side	5,63 €	6,70 €
32_054a	1242548	Brake cylinder set for BMW-Models years of manufacture 09/1981-09/1981 Ø:13mm, "Single Disk"	177,98 €	211,80 €
32_054a	2302371	Brake piston set (Master cylinder piston), Magura, 12mm 1 brake disc	35,63 €	42,40 €
32_054b	1238392	Brake piston set (Master cylinder piston), Magura, 13mm 1 brake disc	53,28 €	63,40 €
32_054c	1454474	Brake piston set (Master cylinder piston), Magura, 14mm 1 brake disc	40,08 €	47,70 €
32_054c	1242873	Brake cylinder set for BMW R60/7-> and R65LS from year of manufacture 09/1980 Ø:15mm, "double disk"	177,56 €	211,30 €
32_054d	1242549	Brake cylinder for BMW-Models years of manufacture 09/1981-09/1981 Ø:16mm, "double disk"	157,73 €	187,70 €
32_054d	2334101	Brake piston set (Master cylinder piston), Magura, 15mm 2 brake discs	35,63 €	42,40 €
32_054e	1238393	Brake piston set (Master cylinder piston), Magura, 16mm 2 brake discs	40,08 €	47,70 €
32_054f	2310785	Brake cylinder set for BMW R65 and R80-R100 from year of manufacture 04/1989 Ø=14mm	155,55 €	185,10 €
32_055	1242555	Brake lever for BMW R45, R65 and R80/7-R100, from year of manufacture 09/1980	44,29 €	52,70 €
32_059	1242563	Throttle control housing for BMW R45, R65 and R80-R100, R65GS, R80G/S, years 09/1980-09/1984	60,34 €	71,80 €
32_061	1451796	Lever bushing for BMW R80GS/R100GS and R80R/R100R, from year of manufacture 09/1990	1,34 €	1,60 €
32_061	1232662	Lever bushing for BMW R45-R100 and R60/6-R100RT, from year of manufacture 09/1980 and for BMW R65GS-R100GS	3,70 €	4,40 €
32_062a	2302368	Throttle control unit complete for BMW R45-R100, years of manufacture 09/1981-09/1984 15mm, 2 brake disks, 1 cable	184,29 €	219,30 €
32_062b	2310747	Throttle control unit complete for BMW R65-R80RT, from year of manufacture 09/1985 15mm, 2 cables and for BMW R100RS/RT from year of manufacture 04/1989	216,30 €	257,40 €
32_062c	2310742	Throttle control unit complete for BMW R80R, R80GS, R100R and R100GS, from year of manufacture 09/19 13mm, 2 cables	170,00 €	202,30 €
32_063	2302363	Throttle control unit for BMW R45-R100, years of manufacture 09/1980-09/1981, Ø=16mm for 2 brake disks, 1 cable	192,10 €	228,60 €
32_063a	2302367	Throttle control unit for BMW R45-R65, years of manufacture 1978-1985, Ø=12mm and for BMW R65GS-R80ST, years of manufacture 1980-1992, for 1 brake disc	177,39 €	211,10 €
32_063b	1234847	Throttle control unit for BMW R90S-R100RS, years of manufacture 09/1975-09/1980, 40mm stroke	116,81 €	139,00 €
32_064	1232981	Throttle control unit for BMW R50/5-R90S, until year of manufacture 08/1974	185,04 €	220,20 €
32_065	32980	Clutch control unit for BMW R50/5-R90S until year of manufacture 09/1974	125,71 €	149,60 €
32_071	30878	Cable adjustor screw M10 x 1 for BMW R60/6-R100, with slot	7,73 €	9,20 €
32_071	30876	Cable adjustor screw for BMW R50/5, R60/5 and R75/5, WITHOUT slot	6,30 €	7,50 €
32_072	1232660	Clutch control housing for BMW R50/5-R90S until year of manufacture 1975	69,83 €	83,10 €
32_072	1240796	Clutch control housing for BMW R45-R100 from year of manufacture 09/1980	73,19 €	87,10 €
32_074	1233348	Clutch lever for BMW R50/5-R90S, until year of manufacture 08/1974	49,83 €	59,30 €
32_077	1241862	Clutch control unit for BMW R60/7-R100 from year of manufacture 11/1979 with choke lever	112,52 €	133,90 €
32_078	1234723	Clutch control unit for BMW R60/6-R100 until year of manufacture 11/1979 and R45/R65 without choke lever	125,71 €	149,60 €
32_079a	1234724	Choke lever cover for BMW R60/6 from year of manufacture 08/1980	3,78 €	4,50 €
32_079b	1451975	Cover for choke lever for BMW-models from year of manufacture 09/1980	7,73 €	9,20 €
32_080	9907430	Screw for choke lever for BMW models from year of manufacture 09/1976	1,34 €	1,60 €
32_083	1240790	Choke lever index plate for BMW-models from year of manufacture 09/1976	1,51 €	1,80 €
32_084	1240791	Choke lever lining disk from BMW R60/7	0,92 €	1,10 €



32_085	1451749	Clutch/brake lever bolt for BMW R80-R100, from year of manufacture 09/1990 black	3,03 €	3,60 €
32_092	1451796	Lever bushing for BMW R80GS/R100GS and R80R/R100R, from year of manufacture 09/1990	1,34 €	1,60 €
32_092	1232662	Lever bushing for BMW R45-R100 and R60/6-R100RT, from year of manufacture 09/1980 and for BMW R65GS-R100GS	3,70 €	4,40 €
32_093	1451700	Clutch lever for BMW R80-R100, from year of manufacture 09/1990	38,07 €	45,30 €
32_093	1234848	Clutch lever for BMW R45, R65 and R60/6-R100, years of manufacture 09/1974-09/1984 and for BMW R65GS-R100GS	49,83 €	59,30 €
32_094	1242125	Throttle cable (grip-distributor) for BMW R45, R65, from year of manufacture 09/1980 and R65GS-R80ST 770mm, for high bars	10,34 €	12,30 €
32_094	1242594	Choke cable steering/distributor for BMW R45-R100RT from year of manufacture 09/1980 and R65GS-R100PD from 09/1980, R80R-R100R/MYS from 1991, 1 piece	12,94 €	15,40 €
32_094	1242127	Throttle cable (grip-distributor) for BMW R80, R100RT and R100T, years of manufacture 09/1980-09/198	17,23 €	20,50 €
32_094	1242593	Choke cable steering/distributor for BMW R80, R100, RS/CS from year of manufacture 09/1980 and for BMW R65 from year of manufacture 09/1984	17,23 €	20,50 €
32_094	1242126	Throttle cable (grip-distributor) for BMW R65GS-R80ST, from year of manufacture 09/1980 640mm, for flat bars	21,76 €	25,90 €
32_094	1242128	Throttle cable (grip-distributor) for BMW R100/7, R100CS and R100RS, years 09/1980-09/1984 for flat bars	21,93 €	26,10 €
32_096	2302232	Throttle cable (distributor-carburettor) for BMW R45, R65, R65GS-R80ST, from year 09/1980 short	12,10 €	14,40 €
32_096	01342	Grommet for throttle cable distributor	2,52 €	3,00 €
32_096	1242135	Throttle cable (distributor-carburettor) for BMW R100/7-RT from year 09/1980 and R80 from 09/1984 long	8,57 €	10,20 €
32_096	1242139	Choke cable distributor/carburettor for BMW-models from year 09/1980, right side for 32mm and 40mm carburators	12,10 €	14,40 €
32_097	1454605	Choke cable distributor/carburettor for BMWmodels from year 09/1980, left side, for 32mm carburators	8,57 €	10,20 €
32_097	1242138	Choke cable distributor/carburettor for BMW-models from year 09/1980, for 32mm carburetor fits for left or right side, 1 piece	14,12 €	16,80 €
32_098	33550	Nipple adaptor for BMW R60/6-R100from year of manufacture 09/1975, Ø 10mm	6,47 €	7,70 €
32_098	11440	Nipple adaptor for BMW R26, R27, R50-R69S and for BMW R50/5-R90S on lever until year of manufacture 09/1975	6,47 €	7,70 €
32_098	30040	Brake cable bolt WITHOUT thread for BMW R50-R69S and R50/5-R60/6 drum brake, front	7,73 €	9,20 €
32_100a	1234515	Brake cable for BMW R50/5-R60/6 for low Euro handlebar, standard quality	8,82 €	10,50 €
32_100a	1234516	Brake cable for BMW R50/5-R60/6 for low Euro handlebar, premium quality	21,93 €	26,10 €
32_100b	34516	Brake cable for BMW R50/5-R60/6, 15cm longer for high or wide bars	12,35 €	14,70 €
32_101a	1230041	Clutch cable for BMW R50/5, R60/5 and R75/5 for low Euro bars	7,90 €	9,40 €
32_101b	1230042	Clutch cable for BMW R50/5, R60/5 and R75/5, 15cm longer for high or wide bars	8,32 €	9,90 €
32_101c	1230044	Clutch cable for BMW R50/5, R60/5 and R75/5, 30cm longer for very high bars	12,10 €	14,40 €
32_101f	1233098	Clutch cable for BMW R60/6-R100 until year of manufacture 09/1984, 1410mm and for BMW R45/R65, R80 from year of manufacture 1978, for low bars	12,10 €	14,40 €
32_101h	1235744	Clutch cable for BMW R60/6-R100RT and R45-R80 until year of manufacture 1978, long and for BMW R65GS-R100PD, (1520mm), high bars	12,44 €	14,80 €
32_103	36616	Throttle cable for BMW R100/7, R100RT, R100T, and R100RS, years of manufacture 1976/09/1980 for carburettor 94/40/..	13,36 €	15,90 €
32_103	236612	Throttle cable for BMW R75/5-R80/7, R100 and R45, R65, until year 09/1980	6,05 €	7,20 €
32_103	72355	Throttle cable for BMW R51/2-R68	5,38 €	6,40 €
32_103	72357	Throttle cable for BMW R51/2-R68, 30cm longer for very high bars	5,97 €	7,10 €
32_103	72348	Throttle cable for BMW R50-R69S, R50/5-R60/7	5,13 €	6,10 €
32_103	72349	Throttle cable for BMW R50-R69S, R50/5-R60/7 and R90S, 15cm longer for high or wide bars	5,13 €	6,10 €
32_103	72350	Throttle cable for BMW R50-R69S, R50/5-R60/7 and R90S, 30cm longer for very high bars	5,13 €	6,10 €
32_103	1236617	Throttle cable for BMW R90S	19,16 €	22,80 €
32_103a	2311828	Throttle cable for BMW R100R and R100GS, right side, from year of manufacture 1988	23,19 €	27,60 €
32_103b	1236611	Throttle cable for BMW R50/5, R60/5, R60/6 and R60/7, until year of manufacture 08/1980, 10cm longer OEM Quality	9,16 €	10,90 €
32_103e	1236614	Throttle cable for BMW R75/5-R80/7 and R100, years of manufacture 09/1978-08/1980 1146mm	20,42 €	24,30 €
32_103f	0236613	Throttle cable for BMW R75/5-R80/7, R100 and R45/R65, until year 09/1980, 8cm longer for high or wide bars	6,30 €	7,50 €
32_103h	236614	Throttle cable for BMW R75/5-R80/7, R100 and R45, R65, until year 09/1980, 30cm longer for very high bars	8,24 €	9,80 €
32_103k	1454582	Throttle cable for BMW R45/R65 and R80, left side, from year 09/1984 and R100RS from year 1986	12,02 €	14,30 €
32_103ka	1454583	Throttle cable for BMW R65 and R80, right side, from year 09/1984 and R100RS from year 1986 for low bars	23,03 €	27,40 €
32_103l	1454584	Throttle cable for BMW R65RT, R80RT and R80GS, left side, from 09/1984 and R100RT from 1986 for high bars	23,36 €	27,80 €
32_103l	1454585	Throttle cable for BMW R65RT, R80RT and R80GS, right side, from 09/1984 and R100RT from 1987 for high bars	23,36 €	27,80 €



32_103ml	1458090	Throttle cable for BMW R80R, R80GS and R100GS, left side, from year of manufacture 09/1990	14,62 €	17,40 €
32_103n	1458091	Throttle cable for BMW R80R, R80GS and R100GS, right side, from year of manufacture 09/1990	18,91 €	22,50 €
32_103o	2311827	Throttle cable for BMW R100R and R100GS, left side, from year of manufacture 1988	19,58 €	23,30 €
32_104	60178	Nut brake cable adjuster for BMW R50-R69S and R50/5-R60/6 drum brake, front	2,77 €	3,30 €
32_105	1117638	Rubber boot clutch/brake cable for BMW R50/5-R100	5,63 €	6,70 €
32_106	30039	Clutch cable grommet for BMW R50/5 and up, long	4,12 €	4,90 €
32_106	1230038	Grommet brake- and clutch cable for BMW R50/5-R100R	5,63 €	6,70 €
32_108	33254	Grommet clutch cable guide for BMW R60/6-R100	1,93 €	2,30 €
32_999	2324962	Clutch cable for BMW R1100RS from year of manufacture 1992	30,25 €	36,00 €
32_999	25600	Throttle control unit "Sport", radial, 1 cable, 46mm stroke aluminum	79,83 €	95,00 €
32_999	2311754	Cable holder R80R-R100PD, 09/90->	3,61 €	4,30 €
32-095	1242014	Cable distributor for BMW models until year of manufacture 09/1980	13,53 €	16,10 €

Group 33 Rear axle

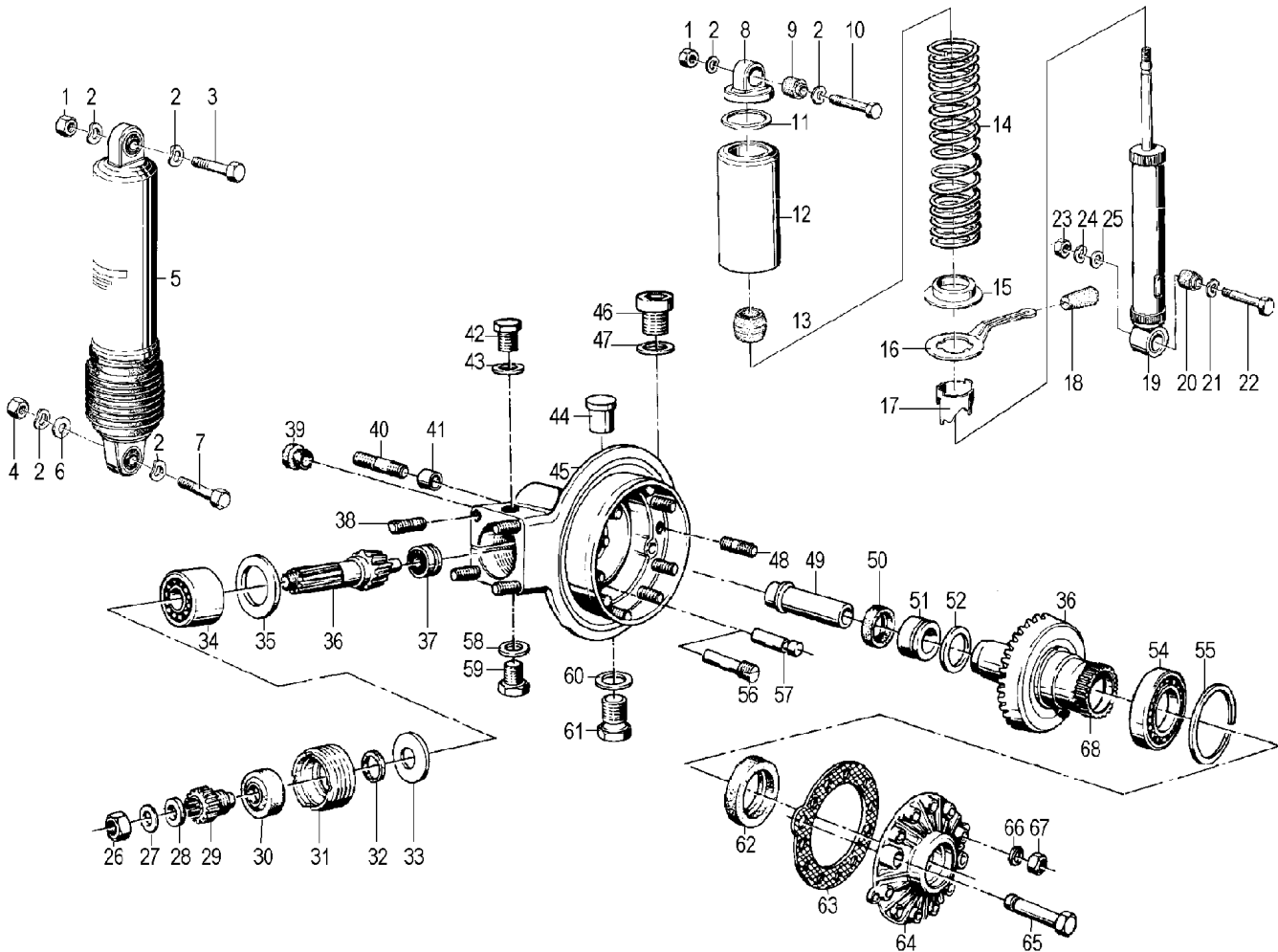

<u>Picture-No.</u>	<u>Article-No.</u>	<u>Description</u>	<u>Net</u>	<u>Gross</u>
33_000	2310904	Swingarm bolt for rear drive for BMW models from year of manufacture 1987, right side	11,34 €	13,50 €
33_000	2311091	Needle bearing for rear drive for BMW models from year of manufacture 1987	54,71 €	65,10 €
33_000	1458097	Cover cap for swingarm / rear drive for BMW R80GS and R100GS from 1987	1,76 €	2,10 €
33_000	2312459	Suspension unit for BMW R80 and R100R, Mystic from year of manufacture 1992 Original BMW	532,35 €	633,50 €
33_000	6000002	Gasket set rear drive (No.A06), for BMW R50/5-R100 until year of manufacture Sep 1980	32,44 €	38,60 €
33_000	2310890	Swingarm bolt for rear drive for BMW models from year of manufacture 1987, left side	17,14 €	20,40 €
33_000	1450095	Thrust ring pinion wheel, Paralever for BMW Models from year of manufacture 1987	4,54 €	5,40 €
33_000	1451182	O-ring rear drive cover for BMW R80GS and R100GS until year of manufacture 1987	3,95 €	4,70 €
33_000	19209	Oil control plug for BMW R45-R100, M8 x 1, for finned rear drive	1,93 €	2,30 €
33_000	2301743	Suspension unit for BMW R65GS until 1992 and R80G/S, ST until 1986 original BMW	337,48 €	401,60 €
33_000	1457605	Gasket ring for brake key for BMW R80-R100 from Sep 1989 rear	0,34 €	0,40 €



33_000	1452127	Suspension unit for BMW R65-R80RT, years of manufacture 1985-1995 Original BMW	354,79 €	422,20 €
33_000	2310508	Suspension unit for BMW R80GS and R100GS, from year of manufacture 09/1988, black original BMW	493,36 €	587,10 €
33_000	6400008	Suspension unit for BMW R80GS and R100GS, from year of manufacture 09/1988, Wilbers Emu On each drivers weight individually adjustable !	450,00 €	535,50 €
33_000	6000045	Gasket set rear drive (No.A07), for BMW R45-R100 years of manufacture 09/1980-09/1984	31,43 €	37,40 €
33_003	9901169	Suspension unit locking screw for BMW R50/5-R100RS, upper, rear	6,89 €	8,20 €
33_005b	1236110	Suspension unit set for BMW for R50/5-R100 until year of manufacture 09/1984, IKON identical to KONI	341,93 €	406,90 €
33_005bb	091282	Spring Set (pair) for Ikon for BMW R50/5-R100, rear, extra hard, 9,0mm for sidecar use	69,24 €	82,40 €
33_005c	1237505	Suspension unit set for BMW R45 and R65 until year of manufacture 09/1984, IKON	324,62 €	386,30 €
33_005d	236110	Suspension unit for BMW R60/6-R100, reinforced, left side Original BMW	281,26 €	334,70 €
33_005d	1235883	Suspension unit for BMW R60/6-R100RT until year of manufacture 09/1984, left side Original BMW	281,26 €	334,70 €
33_005d	1235884	Suspension unit for BMW R60/6-R100RT until year of manufacture 09/1984, right side original BMW	281,26 €	334,70 €
33_005d	1231895	Suspension unit for BMW R50/5, R60/5 and R75/5, reinforced, left side Original BMW	372,10 €	442,80 €
33_005d	1231894	Suspension unit for BMW R50/5, R60/5 and R75/5, reinforced, right side Original BMW	372,10 €	442,80 €
33_005e	236111	Suspension unit for BMW R60/6-R100, reinforced, right side, rear original BMW	281,26 €	334,70 €
33_005u	1240811	Rubber boot niveau-shocks for BMW R60/6-R90S, R80 and R100	43,19 €	51,40 €
33_007	14337	Suspension unit locking screw for BMW R26 and R27, rear, left side stainless steel	7,14 €	8,50 €
33_007	1230249	Suspension unit locking screw for BMW R50/5-R100 until year of manufacture 09/1984 stainless steel	4,37 €	5,20 €
33_008	1230279	Suspension unit upper eye for BMW R50/5-R75/5, rear	79,50 €	94,60 €
33_008a	2301595	Suspension unit upper eye for BMW R60/6-R100 until year of manufacture 1984, rear	5,46 €	6,50 €
33_009	230276	Silent block shock absorber for BMW R50/5-R100 from year of manufacture 09/1984, upper	4,79 €	5,70 €
33_010	9901169	Suspension unit locking screw for BMW R50/5-R100RS, upper, rear	6,89 €	8,20 €
33_011	1237288	Suspension unit flat washer for BMW R50/5-R100 until year of manufacture 1984	2,61 €	3,10 €
33_012a	1230277	Shock cover for BMW R50/5, R60/5 and R75/5 until year of manufacture 08/1973, rear aluminium	50,92 €	60,60 €
33_012b	1233084	Shock cover for BMW R60/6-R90S, rear aluminium	86,22 €	102,60 €
33_013	1230280	Rear shock stop rubber R50/5-R100 ->84	1,34 €	1,60 €
33_014a	1231893	Spring for BMW R50/5-R100, reinforced for Boge	30,25 €	36,00 €
33_015	1230282	Suspension unit rear shock sping guide ring for BMW R50/5 until year of manufacture 1984, lower	4,20 €	5,00 €
33_017a	1230272	Suspension unit adjusting sleeve for BMW R50/5-R100 until year of manufacture 1984, right side	31,51 €	37,50 €
33_019	1240646	Shock absorber for BMW R50/5-R100 until year of manufacture 09/1984, BOGE	152,27 €	181,20 €
33_019	1240647	Shock absorber for BMW R45/R65, years of manufacture 1978-1985, rear, BOGE	135,38 €	161,10 €
33_019b	1237289	Shock absorber for BMW R45/R65, years of manufacture 1978-1985, rear, BOGE "Heavy Duty"	164,37 €	195,60 €
33_020	30258	Silent block shock absorber for BMW R50/5-R100 from year of manufacture 09/1984, lower	11,26 €	13,40 €
33_022	14337	Suspension unit locking screw for BMW R26 and R27, rear, left side stainless steel	7,14 €	8,50 €
33_022	1230249	Suspension unit locking screw for BMW R50/5-R100 until year of manufacture 09/1984 stainless steel	4,37 €	5,20 €
33_027	30256	Lock plate input pinion gear for BMW R50/5, R60/5 and R75/5	3,53 €	4,20 €
33_028	31093	Washer coupling cardan shaft for BMW R60/6-R100	0,84 €	1,00 €
33_028	1233302	Gasket ring rear drive for BMW R60/6-R100 and breather 51254788	1,93 €	2,30 €
33_028a	30255	Drive coupling pinion wheel for BMW R50/5, R60/5 and R75/5	55,80 €	66,40 €
33_029b	33303	Drive coupling pinion wheel for BMW R60/6-R100	39,16 €	46,60 €
33_030	30356	Radial seal ring, transmission input for BMW R50/5-R100 and R45/R65	9,50 €	11,30 €
33_031	1230355	Threaded connection rear drive for BMW R50/5-R100, R45/R65 and R65GS-R80ST	7,48 €	8,90 €
33_032	1230353	Distance washer for connector on pinion wheel for BMW models from R50/5 and up	4,03 €	4,80 €
33_033	1230525	Washer cam gear shaft for BMW R50/5 and up	1,09 €	1,30 €
33_034	1230247	Bearing pinion shaft for BMW R50/5 and up, front plastic cage	51,85 €	61,70 €
33_035a	30737	Distance ring pinion wheel for BMW R50/5-R75/5, 2,5mm	2,35 €	2,80 €
33_035b	1230717	Distance ring pinion wheel for BMW R50/5-R75/5, 1,5mm	2,35 €	2,80 €
33_035c	30719	Distance ring pinion wheel for BMW R50/5-R75/5, 1,6mm	2,35 €	2,80 €
33_035d	30721	Distance ring pinion wheel for BMW R50/5-R75/5, 1,7mm	2,35 €	2,80 €
33_035e	30723	Distance ring pinion wheel for BMW R50/5-R75/5, 1,8mm	2,35 €	2,80 €
33_035f	30725	Distance ring pinion wheel for BMW R50/5-R75/5, 1,9mm	2,35 €	2,80 €
33_035g	30727	Distance ring pinion wheel for BMW R50/5-R75/5, 2,0mm	2,35 €	2,80 €



33_035h	30729	Distance ring pinion wheel for BMW R50/5-R75/5, 2,1mm	2,35 €	2,80 €
33_035i	30731	Distance ring pinion wheel for BMW R50/5-R75/5, 2,2mm	2,35 €	2,80 €
33_035j	30733	Distance ring pinion wheel for BMW R50/5-R75/5, 2,3mm	2,35 €	2,80 €
33_035k	30735	Distance ring pinion wheel for BMW R50/5-R75/5, 2,4mm	2,35 €	2,80 €
33_036	1233288	Crown and pinion wheel set 37:11 for BMW R60/5, R60/6, R60/7, R80/7, R80TIC, R80 und R80RT	320,17 €	381,00 €
33_036c	33286	Crown and pinion wheel set 34:11 for BMW R90/6 and R100/7	324,62 €	386,30 €
33_036e	1233289	Crown and pinion wheel set 32:9 (3,56) for BMW R50/5, R60/7, R60/6-USA	324,62 €	386,30 €
33_037a	30244	Needle bearing for pinion wheel for BMW R50/5-R100 until year of manufacture 09/1980	41,51 €	49,40 €
33_037b	36995	Needle bearing for pinion wheel for BMW R45-R100 from year of manufacture 09/1980	27,65 €	32,90 €
33_038	1241928	Stud bolt rear drive / swing arm for BMW R50/5-R100 and R45/R65 until year of manufacture 09/1980 and for cylinder base for BMW R51/3-R69S, STAINLESS STEAL	4,12 €	4,90 €
33_040	9908177	Stud bolt rear drive / shock absorber for BMW R50/5-R100 until year of manufacture 08/1983 M10x55	2,77 €	3,30 €
33_040	1452062	Bolt gear/shock for BMW R65-R80 from year of manufacture 1985	32,86 €	39,10 €
33_042	19225	Oil drain screw / Oil filler screw for BMW R50/5-R100, M12 x 1,5	2,02 €	2,40 €
33_043	63130	Gasket ring, 12x16x1,5 - aluminium	0,25 €	0,30 €
33_044a	1232581	Breather rear drive R50/5-R100 ->09/80	27,90 €	33,20 €
33_044b	1238838	Engine breather screw, transmission for BMW-models from year of manufacture 09/1980	20,42 €	24,30 €
33_045	33281	Rear drive for BMW R75/5, R75/6, R75/7, R80/7, 32:10 overhauled	709,75 €	844,60 €
33_045	1241093	Rear drive for BMW R50/5, R60/6, R60/7, 32:9	492,52 €	586,10 €
33_045	1238660	Rear drive for BMW R45 and R65, 34:8 used	236,97 €	282,00 €
33_046	19124	Oil drain screw / Oil filler screw for BMW R50/5-R100, M18, hexagon	3,28 €	3,90 €
33_050	04337	Radial seal ring, drive coupling for BMW R50-R69S, R50/5-R100 and R45/R65	3,78 €	4,50 €
33_051a	1242738	Needle bearing for crown wheel for BMW R50/5-R100 until year of manufacture 09/1984	96,30 €	114,60 €
33_051b	42367	Needle bearing for crown wheel for BMW R80ST and R80G/S	30,25 €	36,00 €
33_051c	32005	Roller bearing tapered for BMW R65-R80RT, years of manufacture 1985-1995 and for BMW R100 from year of manufacture 1987, inner, small	13,78 €	16,40 €
33_052a	38931	Thrust ring crown wheel for BMW R50-R69S and R50/5-R100, 1,6mm	19,83 €	23,60 €
33_052a	1242461	Thrust ring crown wheel for BMW R65GS, R80G/S and R80ST, 2,7mm	3,70 €	4,40 €
33_052b	38932	Thrust ring crown wheel for BMW R50-R69S and R50/5-R100, 1,6mm	19,83 €	23,60 €
33_052b	1242462	Thrust ring crown wheel for BMW R65GS, R80G/S and R80ST, 2,8mm	3,70 €	4,40 €
33_052c	1242463	Thrust ring crown wheel for BMW R65GS, R80G/S and R80ST, 2,9mm	3,70 €	4,40 €
33_052c	32769	Thrust ring crown wheel for BMW R50-R69S and R50/5-R100, 1,7mm	19,83 €	23,60 €
33_052d	30527	Thrust ring crown wheel for BMW R50-R69S and R50/5-R100, 1,8mm	19,83 €	23,60 €
33_052d	1242464	Thrust ring crown wheel for BMW R65GS, R80G/S and R80ST, 3,0mm	3,70 €	4,40 €
33_052e	1242465	Thrust ring crown wheel for BMW R65GS, R80G/S and R80ST, 3,1mm	3,70 €	4,40 €
33_052e	31238	Thrust ring crown wheel for BMW R50-R69S and R50/5-R100, 1,9mm	19,83 €	23,60 €
33_052f	1242466	Thrust ring crown wheel for BMW R65GS, R80G/S and R80ST, 3,2mm	3,70 €	4,40 €
33_052f	30528	Thrust ring crown wheel for BMW R50-R69S and R50/5-R100, 2,0mm	19,83 €	23,60 €
33_052g	1242467	Thrust ring crown wheel for BMW R65GS, R80G/S and R80ST, 3,3mm	3,70 €	4,40 €
33_052g	31239	Thrust ring crown wheel for BMW R50-R69S and R50/5-R100, 2,1mm	34,54 €	41,10 €
33_052h	1242468	Thrust ring crown wheel for BMW R65GS, R80G/S and R80ST, 3,4mm	3,70 €	4,40 €
33_052h	30529	Thrust ring crown wheel for BMW R50-R69S and R50/5-R100, 2,3mm	23,70 €	28,20 €
33_052i	30530	Thrust ring crown wheel for BMW R50-R69S and R50/5-R100, 2,2mm	20,42 €	24,30 €
33_052j	30531	Thrust ring crown wheel for BMW R50-R69S and R50/5-R100, 2,4mm	21,60 €	25,70 €
33_052k	30532	Thrust ring crown wheel for BMW R50-R69S and R50/5-R100, 2,5mm	19,83 €	23,60 €
33_054	19064	Bearing crown wheel for BMW R50-R69S and R50-R100	34,54 €	41,10 €
33_054b	42210	Grooved ball bearing mono-lever for BMW from year of manufacture 1980 crown wheel, big	86,30 €	102,70 €
33_055a	1230535	Distance washer crown wheel, 2-arm swing, 0,180mm	11,60 €	13,80 €
33_055d	1230538	Distance washer crown wheel, 2-arm swing, 0,500mm	11,60 €	13,80 €
33_055e	1230539	Distance washer crown wheel, 2-arm swing, 0,630mm	8,66 €	10,30 €
33_055ee	1230540	Distance washer crown wheel, 2-arm swing, 0,750mm	8,66 €	10,30 €
33_055ef	1230541	Distance washer crown wheel, 2-arm swing, 0,880mm	8,66 €	10,30 €
33_055g	1241704	Distance washer crown wheel, 1-arm swing, 0,300mm	11,34 €	13,50 €
33_055i	2310549	Distance washer crown wheel, 1-arm swing, 0,500mm	6,30 €	7,50 €
33_056	2301699	Bushing for brake key for rear drive cover article number: 1241940	9,50 €	11,30 €
33_058	63130	Gasket ring, 12x16x1,5 - aluminium	0,25 €	0,30 €
33_059	19225	Oil drain screw / Oil filler screw for BMW R50/5-R100, M12 x 1,5	2,02 €	2,40 €
33_060	2027	Gasket ring oil drain screw, M14x20x2	0,76 €	0,90 €
33_061	07163	Oil drain screw for BMW R24-R69S, M14, magnetic zincked	3,28 €	3,90 €
33_061a	07104	Oil filler screw for BMW R24-R69S, M14 x 1,5 zincked	2,10 €	2,50 €



33_062	41619	Radial seal ring, transmission, mono-swingarm for BMW models from year of manufacture 09/1984 and for BMW R65GS-R100GS from year of manufacture 09/1980	25,21 €	30,00 €
33_062	3004343	Radial seal ring, crown wheel for BMW R50-R69S and R50/5-R100 original BMW	18,91 €	22,50 €
33_063	2311097	Gasket for rear drive from year of manufacture Sep 1980	3,28 €	3,90 €
33_063	2311096	Gasket for rear drive for year of manufacture Sep 1969 bis Sep 1980	4,96 €	5,90 €
33_065	9932881	Lock washer for shafts, Ø 10,00mm	0,50 €	0,60 €
33_068	0001415	Drive coupling (rear drive) for BMW R50/5, R60/5 and R75/5 to be welded into the crown wheel	120,84 €	143,80 €
33_068	0001416	Drive coupling (rear drive) for BMW R60/6-R100 to be welded into the crown wheel	112,44 €	133,80 €
33_068c	30810	Drive coupling repair (rear drive) for BMW R50/5-R100 delivered dissected!!!	164,37 €	195,60 €
33_999	1450076	Threaded connection rear drive paralever for BMW R80GS, R100GS, R80R and R100R from 1987 and up	25,88 €	30,80 €
33_999	1451185	Radial seal ring, pinion wheel, Paralever, for BMW models from year of manufacture 1987	4,29 €	5,10 €
33_999	1237586	Spring for BMW R45 and R65, rear suspension, reinforced	35,29 €	42,00 €
33_999	1241766	Shock absorber for BMW R80G/S until year of manufacture 09/1983	164,37 €	195,60 €
33_999	1458322	Shock absorber for BMW R80GS and R100GS years of manufacture 1987-1990	216,30 €	257,40 €



Group 34 Brake

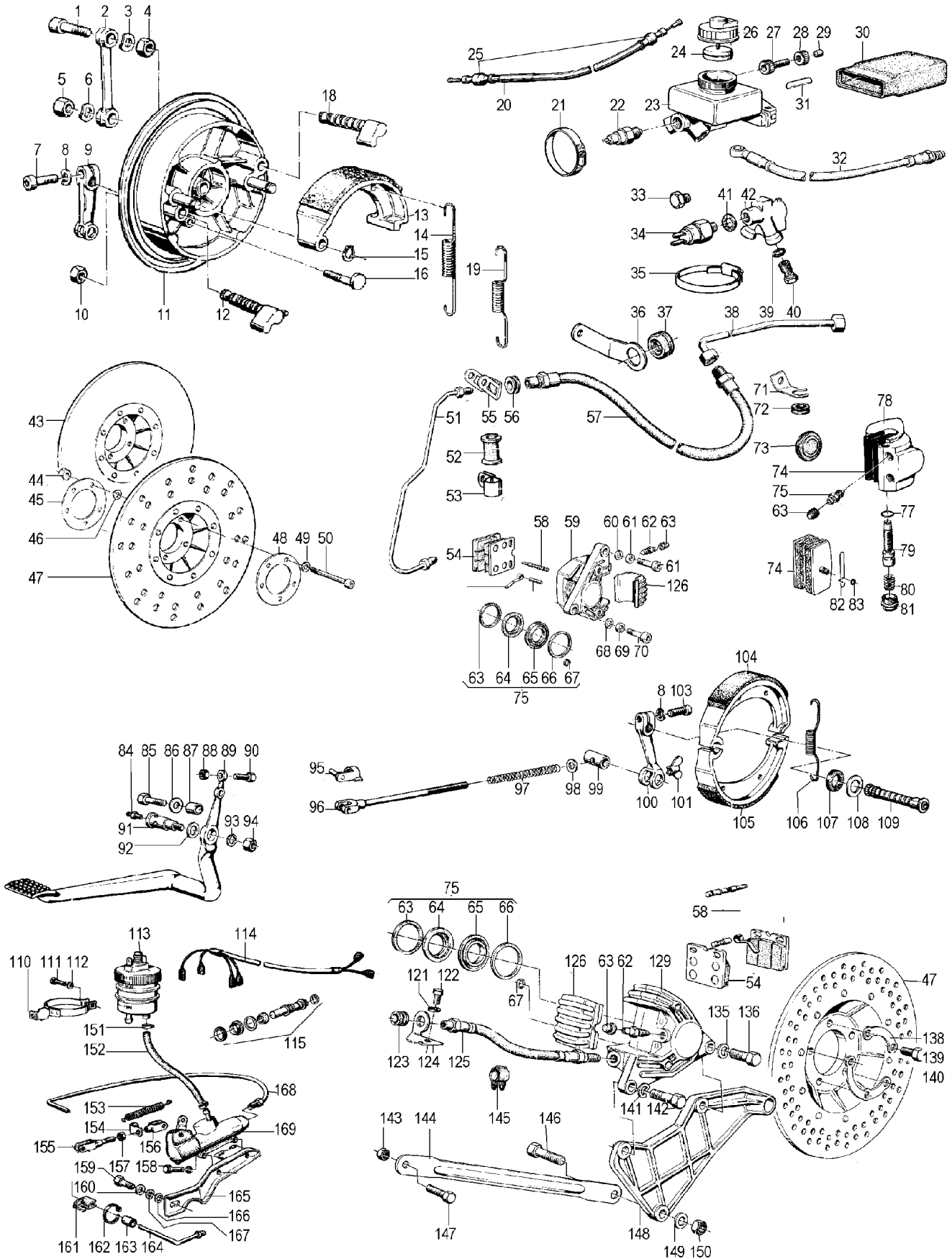

<u>Picture-No.</u>	<u>Article-No.</u>	<u>Description</u>	<u>Net</u>	<u>Gross</u>
34_000	41563	Brake hose steel coated for BMW R100CS from year of manufacture 09/1980, front, upper Lucas, with expertise	43,19 €	51,40 €
34_000	1242759	Brake hose for BMW R100S, RS, RT, years of manufacture 1976-1984, rear 258mm	31,51 €	37,50 €



34_000	2310786	Brake cylinder set for BMW R80GS-R100PD years of manufacture 1991-1995 Ø:13mm	142,77 €	169,90 €
34_000	9407510	Brake fluid 1/4 Liter, DOT 4	4,29 €	5,10 €
34_000	2302369	Brake cylinder set for BMW R45 and R65, R65GS-R80ST from year of manufacture 09/1981 Ø=12mm	177,56 €	211,30 €
34_001	98211	Screw M 8 x 65, cylinder-head Allen® key	0,76 €	0,90 €
34_002	2060338	Stabiliser for brake plate for BMW R50/5-R60/7 used	25,13 €	29,90 €
34_007	98158	Screw M 6 x 20, cylinder-head Allen® key, flat-head	0,50 €	0,60 €
34_009	1230011	Brake lever for BMW R50/5, R60/5, R60/6 and R60/7, front upper and lower used	19,83 €	23,60 €
34_011a	1230024	Brake anchor plate for BMW R50/5-R60/6 until year of manufacture 09/1974, WITHOUT attachment parts used	103,87 €	123,60 €
34_011b	1233681	Brake anchor plate for BMW R50/5-R60/6 from year of manufacture 09/1974, WITHOUT attachment parts only for 17mm wheel axle !	69,08 €	82,20 €
34_012	1230016	Brake spanner for BMW R50/5-R60/6, front lower	63,19 €	75,20 €
34_013	2311079	Brake-shoe Set for BMW R50/5-R60/6, front (Set = 2 pc. for 1 front wheel)	40,34 €	48,00 €
34_014	1230020	Brake-shoe spring for BMW R50/5-R60/7, front upper and R51/3-R69S	2,77 €	3,30 €
34_015	34066	Lock ring brake shoe for BMW R50/5, R60/5, R75/5 and R60/6	0,25 €	0,30 €
34_016	1230010	Eccentric bolt front brake for BMW R50/5, R60/5, R75/5 and R60/6	40,42 €	48,10 €
34_018	1230018	Brake spanner for BMW R50/5-R60/6, front upper	25,55 €	30,40 €
34_019	2060237	Brake-shoe spring for BMW R50/5-R60/7, front lower	2,44 €	2,90 €
34_021	61026	Clamp fork boot for BMW R50/5-R100/7 (clamp with screw)	1,34 €	1,60 €
34_023	1234381	Brake cylinder for BMW R75/6-R100RT below the fuel tank until year of manufacture 09/1980 Ø=14mm, "single disk"	321,68 €	382,80 €
34_023	1234379	Brake cylinder for BMW R75/6-R100RT below the fuel tank until year of manufacture 09/1980 Ø=17mm, "double disk"	369,08 €	439,20 €
34_023a	1234926	Brake cylinder repair kit for BMW-Models from from 09/1975-09/1980 14mm, 1 brake disc, (below tank)	75,97 €	90,40 €
34_023b	1234924	Brake cylinder Repair Kit for BMW R75/6-R90/6 until year of manufacture 09/1975 14mm, (below tank)	76,72 €	91,30 €
34_023bb	0004924	O-ring-Set brake cylinder and tank for BMW R75/6, R90/6 and R90S until year of manufacture 09/1975	4,29 €	5,10 €
34_023c	1234925	Brake cylinder Repair Kit for R90S until year of manufacture 08/1975 16mm, (below tank)	69,50 €	82,70 €
34_023d	1234927	Brake cylinder Repair Kit for BMW R90S from year of manufacture 09/1975 17mm, (below tank)	62,44 €	74,30 €
34_023e	1234470	Brake fluid container, under fuel tank for BMW-Models until year of manufacture 09/1980	66,39 €	79,00 €
34_023f	1242547	Brake fluid container boot & washer for BMW R80/7-R100 from year of manufacture 09/1976 and for BMW R45 and R65 from year of manufacture 09/1980	10,76 €	12,80 €
34_025a	1234400	Brake cable for BMW R75/6-R90S until year of manufacture 08/1975, Ø:6mm for standard bars	17,56 €	20,90 €
34_025b	1234857	Brake cable for BMW R75/6 from year of manufacture 09/1957, Ø:7mm for low bars, disk brake	21,01 €	25,00 €
34_025c	1235809	Brake cable for BMW R75/6-R100T from year of manufacture 09/1975, Ø:7mm for high bars, disk brake	21,09 €	25,10 €
34_030	1233559	Dust cover for brake cylinder for BMW R75/6-R100 below tank	19,33 €	23,00 €
34_032	1238218	Brake pipe for BMW R45T, upper	3,95 €	4,70 €
34_032	1242904	Brake hose for BMW R45 and R65, from year of manufacture 09/1981, upper, long	29,75 €	35,40 €
34_032a	1239825	Brake hose for BMW R45 and R65, years of manufacture 1978-09/1981, upper, short	26,22 €	31,20 €
34_032b	1239827	Brake hose for BMW R45 and R65, years of manufacture 09/1978-09/1981, upper, long	33,45 €	39,80 €
34_032c	1237236	Brake pipe for BMW R45 and R65, upper	19,41 €	23,10 €
34_032f	1241565	Brake hose for BMW R65, R80, R100RT, front, upper and RT from year of manufacture 09/1980	41,68 €	49,60 €
34_034	1244334	Brake light switch hydraulic, years of manufacture 1974-1980 - junction underneath tank and for BMW 45 and R65 until year of manufacture 09/1984	14,20 €	16,90 €
34_036b	1234628	Brake hose holder for BMW R75/7-R100, upper	2,61 €	3,10 €
34_036c	1241561	Brake hose holder for BMW R80-R100, lower left	10,76 €	12,80 €
34_036d	1241562	Brake hose holder for BMW R80-R100, lower right	13,70 €	16,30 €
34_037	34629	Grommet brake hose, upper for BMW R60/7 and up until year of manufacture 09/1984	4,79 €	5,70 €
34_037	1233159	Grommet brake hose, lower for BMW R75/6 and up	1,93 €	2,30 €
34_040a	1242205	Hollow bolt for brake hose, M10x1, for BMW R45-R100 from year of manufacture 09/1981 original BMW	4,29 €	5,10 €
34_040b	42206	Hollow bolt for brake hose, M10x1 aluminum	5,97 €	7,10 €
34_040c	42205	Double hollow screw for brake hose, M10x1 aluminum, hard coal	6,55 €	7,80 €
34_042	1241567	Brake hose distributor for BMW R100RS from year of manufacture 09/1980 4 connections	37,73 €	44,90 €
34_042	1241568	Brake hose distributor for BMW R80/7 and R100/7 from year of manufacture 09/1980 3 connections	33,53 €	39,90 €
34_042	1239831	Brake hose distributor for BMW from year of manufacture 09/1981, ATE 3 connections	30,25 €	36,00 €
34_047	1236567	Brake disc for BMW R75/6-R100/7, without drilled holes (1st series)	161,01 €	191,60 €



34_047a	1236566	Brembo-Brake disc for BMW-Models years of manufacture 09/1973-09/1984 and R65LS, front and for BMW R100S/CS/RS/RT, rear	132,44 €	157,60 €
34_047b	2310143	Brake disc for BMW R80GS and R100GS from year of manufacture 09/1987 and for BMW R65-R80RT, years of manufacture 06/1988-08/1990	209,50 €	249,30 €
34_047c	1454612	Brake disc for BMW R65-R100, years of manufacture 09/1984-08/1988 for double disc brake	173,03 €	205,90 €
34_047d	1236005	Brembo-Brake disc for BMW R45 and R65 until year of manufacture 09/1980 and for BMW R65GS-R80ST, R75/6-R100 with narrow wheel hub from year of manufacture 09/1980	198,99 €	236,80 €
34_047e	1452174	Brake disc for BMW R65-R80RT, years of manufacture 09/1984-06/1988	272,61 €	324,40 €
34_050	18828	Screw for mounting "one" brake disk, M 8 x 75, cylinder head-Allen® key	2,44 €	2,90 €
34_051a	1232405	Brake pipe for BMW-Models until year of manufacture 08/1980, lower left-side	15,88 €	18,90 €
34_051b	1232406	Brake pipe for BMW-Models until year of manufacture 08/1980, lower right-side	15,88 €	18,90 €
34_051c	1242270	Brake pipe for BMW R65GS and R80G/S	10,84 €	12,90 €
34_054a	2301360	Brake pad set for BMW R45-R100 from 1981, R65-R100RT years of manufacture 09/1984-08/1988 and R100S, RS, RT, rear (Brembo)	24,79 €	29,50 €
34_054b	2310983	Brake pad set for BMW R80R and R100R and K-Models from 1990	25,13 €	29,90 €
34_054c	2314546	Brake pad set for BMW R65-R100RT from 08/1988-1995	25,88 €	30,80 €
34_054d	2314545	Brake pad set for BMW R65-R80RT from year of manufacture 09/1984-08/1989 and R100RS, RT from year of manufacture 09/1987, R80/100GS from year of manufacture 1987-1996	27,31 €	32,50 €
34_055	1233155	Brake hose holder for BMW R75/6-R90S, lower	16,72 €	19,90 €
34_055b	1237256	Brake hose holder for BMW R45 and R65	15,97 €	19,00 €
34_056	1236462	Grommet brake hose, lower for BMW R45/R65, R80GS-R100R upper, R100RS/RT rear also be used for cable management R24-R69S	2,02 €	2,40 €
34_057	34601	Brake hose steel covered for BMW R65LS, year of manufacture 09/1981-09/1984 and BMW R45 and R65 with "double brake disc", Set three-pieces	121,09 €	144,10 €
34_057	38171	Brake hose steel covered for BMW R65 and R80 from year of manufacture 1985 Single disc	56,47 €	67,20 €
34_057	98882	Steel coated brake hose for BMW R75/6-R100/7, for conversion brake cylinder on handle bar for single disc brakes in connenction with hollow screw	57,73 €	68,70 €
34_057	11686	Brake hose steel covered for BMW R80GS, R100 Basic, PD until year of manufacture 08/1990 with TÜV-certificate	55,38 €	65,90 €
34_057	1242106	Brake hose steel covered for BMW R80, R100G/S, ST, PD, years of manufacture 1981-1987 with ABE	55,38 €	65,90 €
34_057	1457909	Brake hose for BMW RT-Modells from year of manufacture 11/1986, upper, long	42,69 €	50,80 €
34_057	91277	Brake hose steel covered for BMW R65RT from year of manufacture 1985, 2-pieces handlebar to slave cylinder. For "two" brake disc.	95,97 €	114,20 €
34_057	0035736	Brake hose steel covered for BMW R80 and R100RT, years of manufacture 10/1980-09/1984 set for dual disk with ABE	121,26 €	144,30 €
34_057	0098882	Steel coated brake hose for BMW R75/6-R100/7, for conversion brake cylinder on handle bar for double disc brakes in connenction with banjo bolt	99,50 €	118,40 €
34_057a	1234699	Brake hose for BMW R75/6-R100 until year of manufacture 09/1980 ATE hinged brake caliper front	82,61 €	98,30 €
34_057b	34600	Brake hose steel coated for BMW R45 and R65, years of manufacture 1978-09/1981 TRW with certificate, 2 pieces	96,05 €	114,30 €
34_057b	1239826	Brake hose for BMW R45 and R65, years of manufacture 10/1978-09/1984, lower	74,54 €	88,70 €
34_057c	1457798	Brake hose steel covered for BMW R80 and R100GS, years of manufacture 1987-1990 and BMW R65-R80RT from year of manufacture 06/1988, with ABE	50,17 €	59,70 €
34_057d	2312692	Brake hose steel covered for BMW R80 and R100R with ABE	53,28 €	63,40 €
34_057f	34700	Brake hose Steel covered for BMW R75/6-R100 until year of manufacture 09/1980 Set 2-pieces with ABE for "double brake disc"	99,50 €	118,40 €
34_057g	1235736	Brake hose for BMW RS + RT-Models until year of manufacture 1995, front, lower	40,59 €	48,30 €
34_057j	0034680	Brake hose steel covered for BMW R80, R100, CS, years of manufacture 09/1981-09/1984 Set 3-pieces with ABE	100,76 €	119,90 €
34_057L	0034681	Brake hose steel covered for BMW R100RS, years of manufacture 10/1980-09/1980 with ABE, three pieces	121,18 €	144,20 €
34_058	1238059	Brake pad mounting kit for all Brembo-brake caliper until year of manufacture 09/1984 and R80GS until year of manufacture 1992	15,97 €	19,00 €
34_058b	1238066	Brake pad pin for BMW R45 and R65, ATE	3,45 €	4,10 €
34_058c	1238065	Brake pad spring for BMW R45 and R65, ATE	10,50 €	12,50 €
34_059c	1450755	Brembo-Brake caliper for BMW R100 from year of manufacture 1987, right side + refitting 2nd disk für BMW R65-R80RT from year of manufacture 09/1984	242,27 €	288,30 €
34_062a	1233124	Screw for brake breather ATE	2,44 €	2,90 €
34_062b	1236793	Brake venting screw for Brembo brake caliper	8,82 €	10,50 €
34_063a	1233125	Dust cap for brake breather ATE for BMW R45/R65, R75/6-R100RT until year of manufacture 09/1980	3,70 €	4,40 €
34_063b	1236794	Brake venting dust cover for Brembo-brake caliper	4,96 €	5,90 €
34_070	9901049	Screw M10x30 hexagon socket for brake caliper from year of manufacture 09/1981	1,76 €	2,10 €
34_073a	2301705	Repair Kit brake caliper ATE for BMW R75/6, R90/6 and R90S with 38mm piston	51,18 €	60,90 €
34_073b	1454809	Gasket set for brake caliper for BMW R45 & R65 ATE	70,00 €	83,30 €
34_073b	3401705	Gasket set for brake caliper ATE 38mm pistons for hinged caliper	18,99 €	22,60 €
34_073c	1233317	Boot brake caliper dust protection, for BMW models from year of manufacture 09/1973-08/1984, ATE	22,10 €	26,30 €
34_073c	3401709	Gasket set for brake caliper ATE für 40mm pistons for hinged caliper	18,99 €	22,60 €



34_073d	2301709	Repair Kit brake caliper ATE with 40mm piston	51,18 €	60,90 €
34_074a	2301358	Brake pad set for BMW R75/6-R100 until year of manufacture 09/1980 for ATE hinged caliper	34,37 €	40,90 €
34_074b	2301359	Brake pad set for BMW R45 and R65 from year of manufacture 09/1978, ATE	27,31 €	32,50 €
34_075a	1458211	Gasket set for Brembo-brake caliper for BMW R80GS-R100PD from year of manufacture 06/1988	25,63 €	30,50 €
34_075a	1454722	Gasket set for Brembo-brake caliper for BMW R65-R80RT from 09/1984 until 06/1988	17,82 €	21,20 €
34_075b	1237234	Repair Kit for Brembo-Brake caliper on BMW R80-R100S, RS, RT front and rear from 09/1976 and for BMW R65GS-R80ST, front	18,66 €	22,20 €
34_075c	2310493	Gasket Set for brake caliper for BMW R65-R80RT from 08/1988 and R100RS/RT from 08/1987	17,39 €	20,70 €
34_075c	1454807	Gasket set for Brembo-brake caliper for BMW R45 and R65	37,82 €	45,00 €
34_077	31469	O-ring brake caliper axle, ATE	2,35 €	2,80 €
34_078	1237303	Brake caliper, from year of manufacture 09/1975 40mm (hinged caliper), ATE	388,24 €	462,00 €
34_080	1231468	Spring for brake caliper axle ATE	2,18 €	2,60 €
34_081	31466	Locking screw for brake caliper for BMW R75/6 and up	13,78 €	16,40 €
34_082	1232513	Brake pad Spring for BMW R75/6-R100 until year of manufacture 09/1980, ATE	6,05 €	7,20 €
34_082a	1454721	Front brake pad mounting kit for BMW R65-R80RT from year of manufacture 1985, front R80GS-R100PD from year of manufacture 1988 and R80GS Basic	12,69 €	15,10 €
34_089	1230043	Foot brake pedal for BMW R50/5-R100 until year of manufacture 09/1980 used	64,87 €	77,20 €
34_089a	1238284	Foot brake pedal for BMW R45 and R65 until year of manufacture 09/1984	51,93 €	61,80 €
34_091	1230221	Bolt for foot brake pedal for BMW R50/5-R100 until year of manufacture 09/1981 standard messure	71,43 €	85,00 €
34_091a	1230222	Bolt for foot brake pedal for BMW R50/5-R100 until year of manufacture 09/1980 +0,2mm oversize with grease nipple	25,97 €	30,90 €
34_095a	34961	Brake rod bolt with lock spring, 6x12mm	4,45 €	5,30 €
34_095b	9934955	Brake rod bolt with lock spring, 6x24mm	2,52 €	3,00 €
34_096a	1450743	Brake rod for BMW R50/5-R75/5, short wheel base, BMW R45 and R64, K75 WITHOUT attachment parts zincked	24,71 €	29,40 €
34_096aa	50743	Brake rod for BMW R50/5-R75/5, short wheel base and BMW R45 and R65 with 6mm security clip	47,65 €	56,70 €
34_096bb	32999	Brake rod for BMW R50/5-R90S, long wheel base complete with 6mm security clip, stainless steel polished	44,62 €	53,10 €
34_097	44138	Brake rod spring stainless steel polished	3,61 €	4,30 €
34_098	44133	Brake rod ring, vaulted stainless steel polished	3,95 €	4,70 €
34_100	1239078	Brake lever for BMW R45/R65, R80/7-R100 and R65GS-R100GS from year of manufacture 09/1980, rear Original New part	57,90 €	68,90 €
34_100a	1230308	Brake lever for BMW R50/5-R100, rear, until year of manufacture 09/1980 used	43,28 €	51,50 €
34_101a	4044115	Wing nut for brake rod for BMW R25-R69S stainless steel chromed	11,18 €	13,30 €
34_103	19625	Screw M 6 x 25, cylinder-head Allen® key	0,17 €	0,20 €
34_104/105	2311088	Brake-shoe Set for BMW R50/5-R100, R45 and R65, rear, until year of manufacture 09/1980 (Set = 2 pc. for 1 rear wheel)	40,34 €	48,00 €
34_104/105a	2311089	Brake-shoe Set for BMW R65LS, rear	44,37 €	52,80 €
34_104/105b	2310523	Brake-shoe Set, rear, years of manufacture 09/1980-09/1989 all R-Models	49,66 €	59,10 €
34_104/105c	2311019	Brake-shoe Set for BMW R80 and R100, rear, from year of manufacture 09/1989	44,37 €	52,80 €
34_104/105d	2311082	Brake-shoe for BMW R65LS, rear upper original BMW	42,77 €	50,90 €
34_105	2311083	Brake-shoe for BMW R65LS, rear lower original BMW	42,77 €	50,90 €
34_105a	1457572	Brake spring anti noise rubber for BMW R60/7-R100 until year of manufacture 09/1989	6,72 €	8,00 €
34_105b	1458148	Brake spring anti noise rubber for BMW R80GS-R100R	2,10 €	2,50 €
34_106a	1457091	Brake-shoe spring for BMW R50/5-R100, rear until year of manufacture 09/1989 and R45, R65, GS, ST	3,11 €	3,70 €
34_106b	1458377	Brake-shoe spring for BMW R80-R100, rear, from year of manufacture 09/1989 also GS, PD, R	5,21 €	6,20 €
34_107	30360	Felt ring for brake key for BMW R50/5-R100, rear	2,52 €	3,00 €
34_107b	06328	O-ring brake spanner for BMW R80/7 and up and for BMW R45/R65, R100 years of manufacture 09/1980-09/1989	0,59 €	0,70 €
34_108	60107	Washer break key pedal rear for BMW R50/5, R60/5 and R75/5 also as replacement for R50-R69S	1,60 €	1,90 €
34_109b	1454836	Brake spanner for BMW R100, from year of manufacture 1980, rear	56,72 €	67,50 €
34_110	1236136	Retaining clamp brake cylinder for BMW R100S, RS, RT, rear	22,77 €	27,10 €
34_113a	1242625	Brake fluid container screw on throttle control for BMW R45/R65, R80/7-R100 and R65GS-R100GS	0,25 €	0,30 €
34_113b	1241961	Brake fluid container for BMW R100RS and R100RT, rear, from year of manufacture 09/1980	21,51 €	25,60 €
34_115a	2302371	Brake piston set (Master cylinder piston), Magura, 12mm 1 brake disc	35,63 €	42,40 €
34_115b	1242791	Brake cylinder repair kit for BMW R100RS, RT from year of manufacture 09/1980, rear 14mm	38,91 €	46,30 €
34_115b	1238392	Brake piston set (Master cylinder piston), Magura, 13mm 1 brake disc	53,28 €	63,40 €
34_115b	1237233	Brake cylinder repair kit for BMW R100S, RS, RT until year of manufacture 09/1980, rear 16mm	30,92 €	36,80 €
34_115c	1454474	Brake piston set (Master cylinder piston), Magura, 14mm 1 brake disc	40,08 €	47,70 €



34_115d	2334101	Brake piston set (Master cylinder piston), Magura, 15mm 2 brake discs	35,63 €	42,40 €
34_115e	1238393	Brake piston set (Master cylinder piston), Magura, 16mm 2 brake discs	40,08 €	47,70 €
34_123	1236462	Grommet brake hose, lower for BMW R45/R65, R80GS-R100R upper, R100RS/RT rear also be used for cable management R24-R69S	2,02 €	2,40 €
34_125b	42759	Brake hose steel covered for BMW R100S, RS and RT, years of manufacture 1976-1984, rear TRW-Lucas with ABE	42,02 €	50,00 €
34_126b	1238058	Dust cover for Brembo-Brake caliper for BMW-Models years of manufacture 09/1980-09/1984	7,39 €	8,80 €
34_126c	1454653	Dust cover for Brembo-brake caliper for BMW R65RT-R100RS until year of manufacture 08/1988	4,62 €	5,50 €
34_138	1235844	Lock plate brake disc for BMW R100S, R100RT and R100RS, rear 2-holes	8,82 €	10,50 €
34_139	98203	Screw M 8 x 30, hexagon	0,25 €	0,30 €
34_140	1235843	Lock plate brake disc for BMW R100S, R100RT und R100RS, rear 3-holes	2,18 €	2,60 €
34_145	1362825	Clamp brake hose for BMW R100S/RT/RS, rear	2,02 €	2,40 €
34_151	1116458	Clamp brake hose container/cylinder for BMW R100S/RT/RS, rear	4,54 €	5,40 €
34_152	1236259	Fluid tube for container-cylinder for BMW R100S, R100RT and R100RS, rear	3,45 €	4,10 €
34_164/168	1242767	Brake pipe for BMW R100S, RS, RT, years of manufacture 09/1980-09/1984, rear	28,32 €	33,70 €
34_169a	1238084	Brake cylinder for BMW R100S, RS, RT until year of manufacture 09/1980, rear	140,76 €	167,50 €
34_169a	1238040	Dust cab brake cylinder for BMW R100RS, R100RT and R100S, rear wheel	6,05 €	7,20 €
34_169b	1241960	Brake cylinder for BMW R100RS, RT from year of manufacture 09/1980, rear	140,76 €	167,50 €
34_999	2312695	Grommet brake hose for BMW R80R und R100R	1,93 €	2,30 €
34_999	41565	Brake hose steel covered for BMW RT, T from year of manufacture 09/1980, front upper	43,19 €	51,40 €
34_999	2310196	Rubber plug for front fender for BMW R80R and R100R	1,09 €	1,30 €
34_999	1458198	Brake cable for BMW R80GS, R100GS from year of manufacture 1987 and R80R, R100R, rear original BMW	26,13 €	31,10 €
34-099	44230	Brake rod bolt, 14mm stainless steel polished	3,19 €	3,80 €



Group 36 Wheels

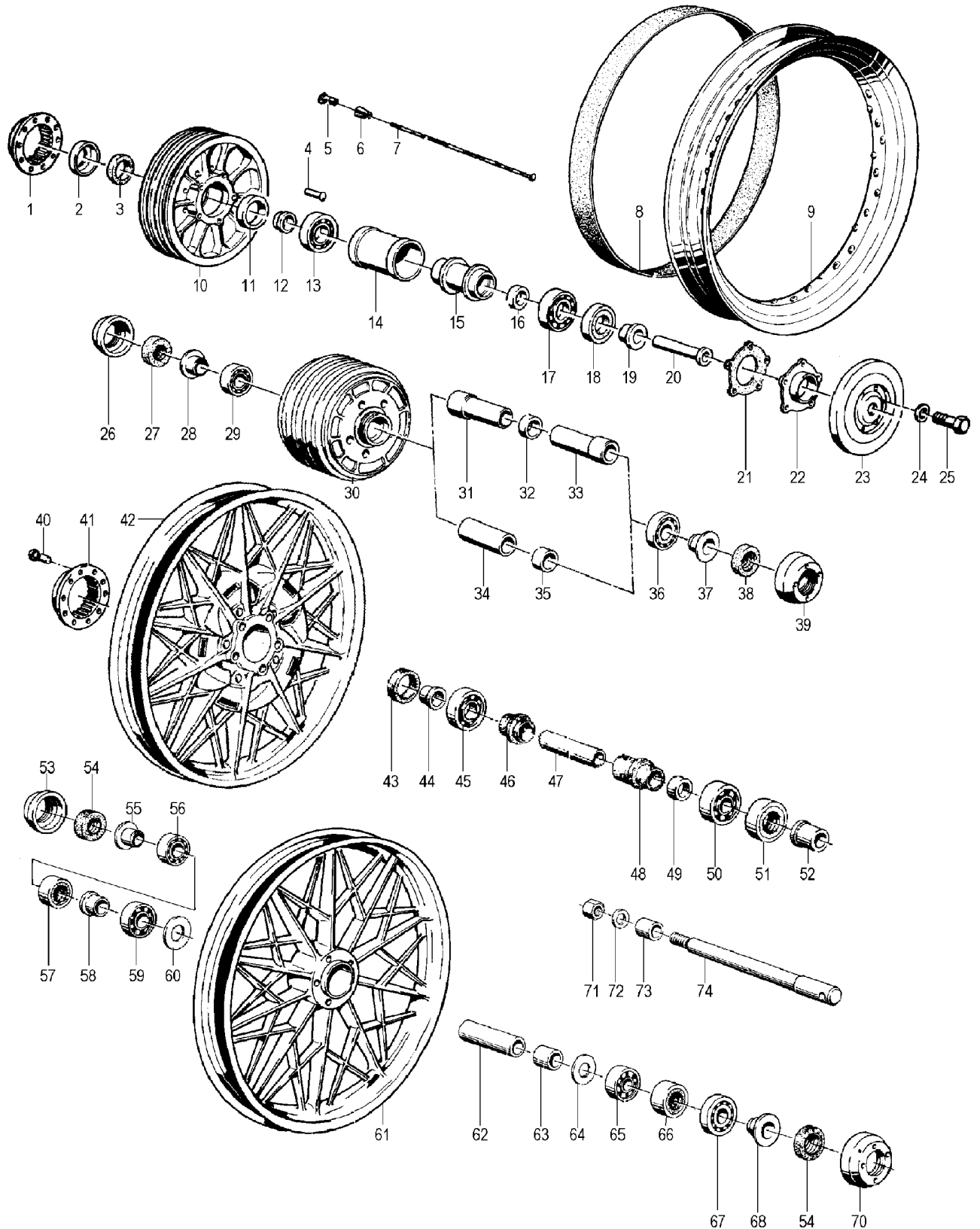

<u>Picture-No.</u>	<u>Article-No.</u>	<u>Description</u>	<u>Net</u>	<u>Gross</u>
36_000	1450821	Bushing wheel bearing for BMW R80GS/Basic/R100GS from 1987, right side	2,77 €	3,30 €
36_000	1450824	Spacer pipe wheel bearing for BMW R65-R100 from year of manufacture 1985 and for BMW K-models	3,87 €	4,60 €
36_000	1450818	Bushing wheel bearing for BMW R80GS/Basic/R100GS/R80R/R100R from 09/1987, left side	3,95 €	4,70 €
36_000	532519	Tire 3.25H19, Bridgestone, BT45F	95,13 €	113,20 €
36_000	1308017	Tire 130/80-17 65H TL, Metzeler, ME55, Lasertec for BMW R80R and R100R	146,30 €	174,10 €
36_000	1458284	Rubber plug for rear wheel hub for BMW R65GS-R100R	10,34 €	12,30 €
36_000	9931697	Shim for tire valve (metal)	0,08 €	0,10 €



36_000	97001	Spoke spanner for nipple M3 - M3,5 - M4 - M4,5 chrome vanadium	11,18 €	13,30 €
36_000	2333226	Wheel screw R80GS-R100PD, R80R-R100R	3,87 €	4,60 €
36_000	30070	Spoke nipple M4	0,42 €	0,50 €
36_000	1209018	Tire 120/90-18 65H TL, Metzeler, ME55, Lasertec for BMW R65, R80, R100 from year of manufacture 10/1984, mono lever	147,06 €	175,00 €
36_000	1450859	Wheel bearing for BMW R65-R100 years of manufacture 1985-1995 R80GS, R100GS up from 1987 front	10,34 €	12,30 €
36_000	909018	Tire 90/90-18 51H TL M/C, Metzeler, Lasertec, for front wheel	95,13 €	113,20 €
36_000	9700101	Spoke spanner for nipple M3,5 - M4 - M4,5 - M5	10,00 €	11,90 €
36_000a	0030070	Spoke nipple M4 stainless steel	0,92 €	1,10 €
36_001a	30325	Drive coupling rear wheel (hub) for BMW R50/5, R60/5 and R75/5	83,70 €	99,60 €
36_001b	32525	Drive coupling wheel (hub) for BMW R60/6-R100	108,99 €	129,70 €
36_003	31701	Radial seal ring, wheel bearing, rear and inner front for BMW R50/5-R100	9,75 €	11,60 €
36_003a	38155	Felt ring for wheel bearing for BMW R25/2-R27 and R50/5-R75/5	2,35 €	2,80 €
36_004a	9947165	Rivet bolt for wheel spline for BMW R50/5-R75/5 and R50-R69S	1,18 €	1,40 €
36_004b	9900800	Rivet bolt for wheel spline for BMW R60/6-R100 until year of manufacture 1984	2,52 €	3,00 €
36_007	1241608	Spoke for BMW R65GS and R80G/S years 1980-1987, M4 x 196, front chromed, WITHOUT nipple, original BMW	4,71 €	5,60 €
36_007	6044	Spoke for BMW R25/3-R27 and R50-R69S, R50/5 and up, rear, M4 x 140 (2x crossed) chromed, with nipple	1,09 €	1,30 €
36_007	8046	Spoke for BMW R50/5-R60/6, M4 x 153, front, drum brake stainless steel, with nipple	1,26 €	1,50 €
36_007	8047	Spoke for BMW R75/6-R100RS, M4 x 176, front, (disk brake) stainless steel, with nipple	1,26 €	1,50 €
36_007	1047	Spoke for BMW R25/3-R27 and R50-R69S, R50/5 and up, rear, M4 x 140 (2x crossed) stainless steel, with nipple	1,26 €	1,50 €
36_007	1452726	Spoke for BMW R80GS, R100GS and R80GS Basic from 1987, M4 x 222, front, for crossed spoked wheel chromed, WITHOUT nipple	3,45 €	4,10 €
36_007a	34592	Spoke for BMW R50/5-R60/6, M4 x 153, front, drum chromed, with nipple, also for BMW GS from year of manufacture 1988, rear	1,09 €	1,30 €
36_007c	34593	Spoke for BMW R75/6-R100RS, M4 x 176, front, (disk brake) chromed, with nipple	1,09 €	1,30 €
36_008	1040	Rim tape - Tube protection rubber suitable for 16 - 21 inch	2,44 €	2,90 €
36_009	1233325	Rim für BMW R50/5-R100, rear, until year of manufacture 09/1980 Aluminium, original BMW	300,92 €	358,10 €
36_009c	933325	Rim für BMW R50/5-R100, rear, until year of manufacture 09/1980 aluminium	172,27 €	205,00 €
36_009d	1233323	Rim for BMW R50/5-R75/5 & R60/6, front, for drum brake Aluminium, original BMW	233,61 €	278,00 €
36_009e	1233321	Rim for BMW R75/6-R100 & R80ST, front, for disk brake, aluminum original BMW	237,98 €	283,20 €
36_009e	0033321	Rim for BMW R75/6-R100 & R80ST, front, for disk brake, aluminum	163,61 €	194,70 €
36_009f	933323	Rim for BMW R50/5-R75/5 and R60/6, front, for drum brake Aluminium	116,39 €	138,50 €
36_010	1239035	Spoke wheel for BMW R60/6-R100, rear for drum brake, measurement rim: 2.15 x 18	618,07 €	735,50 €
36_010	1458453	Front wheel for BMW R80GS, R100GS and R80GS Basic from year of manufacture 09/1990	656,81 €	781,60 €
36_010	2302280	Spoke wheel for BMW R80ST, front for disk brake, measurement rim: 1.85 x 19	535,63 €	637,40 €
36_010b	32437	Wheel hub for BMW R50/5-R60/6, front WITHOUT bearings/bushings/spacers	314,54 €	374,30 €
36_010c	32979	Wheel hub for BMW R60/6-R100 until year of manufacture 1981, rear, empty also replacement for R50/5, R60/5 and R75/5	577,98 €	687,80 €
36_013	13064	Wheel bearing for BMW R26, R27, R50/5-R100 and R45/R65 until year of manufacture 09/1984 and rocker arm for BMW R26, R27, R50-R69S and R50/5-R100, front and rear	16,39 €	19,50 €
36_014	30324	Spacer pipe wheel bearing for BMW R50/5, R60/5 and R75/5, front and rear and for BMW R60/6-R100, rear only	12,10 €	14,40 €
36_015	35737	Spacer pipe wheel bearing for BMW R50/5-R90S, front and rear and for BMW R75/6-R100 and R45/R65, rear	15,97 €	19,00 €
36_015b	35570	Spacer rubber wheel bearing for BMW R50/5-R100	1,34 €	1,60 €
36_017	13064	Wheel bearing for BMW R26, R27, R50/5-R100 and R45/R65 until year of manufacture 09/1984 and rocker arm for BMW R26, R27, R50-R69S and R50/5-R100, front and rear	16,39 €	19,50 €
36_018	30334	Radial seal ring, wheel bearing, rear and outer front for BMW R50/5-R100 until 09/1977	13,78 €	16,40 €
36_019	1230322	Thrust sleeve for BMW R50/5-R100 until year of manufacture 09/1984, left side on wider tires also to be used on right side	6,55 €	7,80 €
36_020	30007	Reducing bush wheel axle for BMW R50/5, R60/5 and R75/5 used	9,50 €	11,30 €
36_021	1232523	Gasket wheel bearing for BMW R50/5-R100	2,61 €	3,10 €
36_022	30337	Cover wheel bearing for BMW R50/5, R60/5 and R75/5	17,65 €	21,00 €
36_022b	32477	Cover wheel bearing for BMW R60/6-R100 until year of manufacture 1984	31,34 €	37,30 €
36_023	30338	Hubcap for BMW R50/5, R60/5 and R75/5 stainless steel	53,03 €	63,10 €
36_023	3033801	Hubcap for BMW R50/5, R60/5 and R75/5 aluminium, polished	45,13 €	53,70 €
36_024	98429	Lock washer A 6 zincked	0,08 €	0,10 €
36_025	098162	Screw M 6 x 35, hexagon with shaft stainless steel	0,50 €	0,60 €
36_025	98162	Screw M 6 x 35, hexagon with shaft	0,17 €	0,20 €



36_027	35836	Radial seal ring, wheel bearing front inner and outer for BMW R75/6-R100 from 1978 and R60/7 from year of manufacture 1978, rear right side, and /7 and up, front outer	5,04 €	6,00 €
36_028	4038142	Thrust sleeve for BMW R50/5-R100, right side and for BMW R45, R65	6,05 €	7,20 €
36_029	13064	Wheel bearing for BMW R26, R27, R50/5-R100 and R45/R65 until year of manufacture 09/1984 and rocker arm for BMW R26, R27, R50-R69S and R50/5-R100, front and rear	16,39 €	19,50 €
36_030	37090	Wheel hub for BMW R75/6-R100RT until year of manufacture 09/1980, front, empty until year of manufacture 09/1974 in connection with add-on-kit stud axle	332,61 €	395,80 €
36_030b	1235819	Wheel hub for BMW R45, R65, R65GS, R80GS and R80ST, front WITHOUT bearings/bushings/spacers	160,08 €	190,50 €
36_032	31140	Spacer ring wheel bearing for BMW R75/6, R90/6 and R90S, front 10,20mm for 14mm axle	5,13 €	6,10 €
36_033	1232423	Distance bushing for wheel axle for BMW R75/6-R90S until year of manufacture 09/1974, 14mm	29,92 €	35,60 €
36_034	37606	Spacer pipe wheel bearing for BMW R75/6-R100 from year of manufacture 09/1974, front for hub with threaded connection	13,95 €	16,60 €
36_034a	1236140	Spacer pipe wheel bearing for BMW R60/7-R100, R45/R65 years of manufacture 1976-1984 "alloy wheel" and for BMW R65GS-R80ST years of manufacture 1980-1992	13,70 €	16,30 €
36_034a	1237606	Spacer pipe wheel bearing for BMW R75/7-R100 until year of manufacture 09/1980, front for hub WITHOUT threaded connection	11,51 €	13,70 €
36_035a	30781	Spacer ring wheel bearing for BMW R25/3-R27 and R50/5-R100RT, 6,30mm	3,03 €	3,60 €
36_035b	30782	Spacer ring wheel bearing for BMW R25/3-R27 and R50/5-R100RT, 6,35mm	3,03 €	3,60 €
36_035c	30783	Spacer ring wheel bearing for BMW R25/3-R27 and R50/5-R100RT, 6,40mm	3,03 €	3,60 €
36_035d	30784	Spacer ring wheel bearing for BMW R25/3-R27 and R50/5-R100RT, 6,45mm	3,03 €	3,60 €
36_035e	30785	Spacer ring wheel bearing for BMW R25/3-R27 and R50/5-R100RT, 6,50mm	3,03 €	3,60 €
36_035f	30786	Spacer ring wheel bearing for BMW R25/3-R27 and R50/5-R100RT, 6,55mm	3,03 €	3,60 €
36_035g	30787	Spacer ring wheel bearing for BMW R25/3-R27 and R50/5-R100RT, 6,60mm	3,03 €	3,60 €
36_035h	31240	Spacer ring wheel bearing for BMW R25/3-R27 and R50/5-R100RT, 6,65mm	3,03 €	3,60 €
36_035i	30788	Spacer ring wheel bearing for BMW R25/3-R27 and R50/5-R100RT, 6,70mm	3,03 €	3,60 €
36_035j	31241	Spacer ring wheel bearing for BMW R25/3-R27 and R50/5-R100RT, 6,75mm	3,03 €	3,60 €
36_035k	30789	Spacer ring wheel bearing for BMW R25/3-R27 and R50/5-R100RT, 6,80mm	3,03 €	3,60 €
36_035l	31242	Spacer ring wheel bearing for BMW R25/3-R27 and R50/5-R100RT, 6,85mm	3,03 €	3,60 €
36_035m	31243	Spacer ring wheel bearing for BMW R25/3-R27 and R50/5-R100RT, 6,90mm	3,03 €	3,60 €
36_035n	31244	Spacer ring wheel bearing for BMW R25/3-R27 and R50/5-R100RT, 6,95mm	3,03 €	3,60 €
36_035o	31245	Spacer ring wheel bearing for BMW R25/3-R27 and R50/5-R100RT, 7,00mm	3,03 €	3,60 €
36_035p	31246	Spacer ring wheel bearing for BMW R25/3-R27 and R50/5-R100RT, 7,05mm	3,03 €	3,60 €
36_035q	31247	Spacer ring wheel bearing for BMW R25/3-R27 and R50/5-R100RT, 7,10mm	3,03 €	3,60 €
36_035r	31248	Spacer ring wheel bearing for BMW R25/3-R27 and R50/5-R100RT, 7,15mm	3,03 €	3,60 €
36_035s	31249	Spacer ring wheel bearing for BMW R25/3-R27 and R50/5-R100RT, 7,20mm	3,03 €	3,60 €
36_036	13064	Wheel bearing for BMW R26, R27, R50/5-R100 and R45/R65 until year of manufacture 09/1984 and rocker arm for BMW R26, R27, R50-R69S and R50/5-R100, front and rear	16,39 €	19,50 €
36_038	35836	Radial seal ring, wheel bearing front inner and outer for BMW R75/6-R100 from 1978 and R60/7 from year of manufacture 1978, rear right side, and /7 and up, front outer	5,04 €	6,00 €
36_039	1232422	Nut for front hubcap for BMW R75/6-R100 until year of manufacture 1980	20,67 €	24,60 €
36_041	1236208	Drive coupling wheel (hub) for BMW R100 years of manufacture 1976-1984, R45/65 years 1978-1985 disk brake	126,05 €	150,00 €
36_042a	1238092	Casted rear wheel R60/6-R100, R45/65 silver, drum drum brake	505,88 €	602,00 €
36_042b	238092	Casted rear wheel R60/6-R100, R45/65 silver, used drum brake, overhauled	342,35 €	407,40 €
36_044	2301737	Thrust sleeve for BMW models with finned gear wheel disk	11,18 €	13,30 €
36_050	13064	Wheel bearing for BMW R26, R27, R50/5-R100 and R45/R65 until year of manufacture 09/1984 and rocker arm for BMW R26, R27, R50-R69S and R50/5-R100, front and rear	16,39 €	19,50 €
36_054	35836	Radial seal ring, wheel bearing front inner and outer for BMW R75/6-R100 from 1978 and R60/7 from year of manufacture 1978, rear right side, and /7 and up, front outer	5,04 €	6,00 €
36_061a	2302284	"Casted front wheel R45/65, 18"', silver, w/out disk"	358,15 €	426,20 €
36_061b	1457361	Casted front wheel R100RS, K75, K100, black	278,15 €	331,00 €
36_061c	1451897	Casted front wheel R65, R80RT, R100RT, silver	489,92 €	583,00 €
36_071	98389	Nut M14 x 1,5 flat for wheel axle for BMW R50/5-R100 and R69S (US-version), front and rear stainless steel	2,18 €	2,60 €
36_072	1233020	Washer for wheel axle for spoked wheel for BMW R60/6-R100, R45-R65LS and for BMW R65GS-R80ST	3,70 €	4,40 €
36_073a	1233491	Distance bushing for wheel axle, 19mm for spoked wheel from september/1973 upto august/1980 and for casted wheel upto aug/1984	17,23 €	20,50 €
36_073b	1242632	Distance bushing for wheel axle from year4 of manufacture 09/1979, 24mm	17,23 €	20,50 €
36_073c	1242633	Distance bushing for wheel axle from year of manufacture 09/1979, 4mm	2,52 €	3,00 €
36_073d	1232285	Distance bushing for wheel axle, until year of manufacture 09/1974, 18mm	19,75 €	23,50 €
36_074	33490	Wheel axle for BMW R75/6-R100 from year of manufacture 1975, front 17mm	92,44 €	110,00 €



36_074	1233490	Wheel axle for BMW R75/6-R100RS, R65GS and R80G/S, front 17mm, stainless steel	52,44 €	62,40 €
36_074	1236144	Wheel axle for BMW R45/R65 and R80ST, front 17mm	73,70 €	87,70 €
36_074a	60336	Wheel axle for BMW R50/5-R90S and R69 US-version until year of manufacture 1975, front 14mm, stainless steel	43,61 €	51,90 €
36_075	132519	Tire 3.50S19, Avon, AM6, Speedmaster for BMW R51/2-R68, classical groove profile, for front wheel	86,55 €	103,00 €
36_076	432518	Tire 110/80V18, Metzeler, Lasertec for BMW R80R and R100R	116,81 €	139,00 €
36_077a	240019	Tire 3.25H19, Heidenau, K44	76,22 €	90,70 €
36_078	540018	Tire 4.00S18, Mitas, H-06	69,16 €	82,30 €
36_080	1408017	Tire 140/80VB17 69V TL, Metzeler, ME55, Lasertec for BMW R80R and R100R	170,00 €	202,30 €
36_080	832519	Tire 3.25H19, Metzeler, ME33, Lasertec, for front wheel	121,09 €	144,10 €
36_080	332518	Tire 3.25H18, Metzeler, ME11	161,01 €	191,60 €
36_080	332519	Tire 3.25H19, Metzeler, ME11	129,41 €	154,00 €
36_080a	0112018	Tire 4.00H18, Heidenau, K36	112,52 €	133,90 €
36_081	20402	Tire air tube 3.25/3.50/4.00-19	13,61 €	16,20 €
36_45	13064	Wheel bearing for BMW R26, R27, R50/5-R100 and R45/R65 until year of manufacture 09/1984 and rocker arm for BMW R26, R27, R50-R69S and R50/5-R100, front and rear	16,39 €	19,50 €
36_999	1242944	Wheel balancing weight 10gr	2,02 €	2,40 €
36_999	1242945	Wheel balancing weight 15gr	2,02 €	2,40 €
36_999	1242946	Wheel balancing weight 20gr	2,10 €	2,50 €
36_999	1242948	Wheel balancing weight 25gr	2,18 €	2,60 €
36_999	1242947	Wheel balancing weight 30gr	2,18 €	2,60 €
36_999	1452748	Valve for tubeless tire (metal)	6,05 €	7,20 €
36_999	98009	Spokes ballance weight, 30gr	2,27 €	2,70 €
36_999	1237595	"Intermediate ring wheel bearing for BMW R100, years of manufacture 1976-1984, ""cast-wheel"" and for R60-R80 years 1976-1984, R45/R65LS years 1978-1985	4,79 €	5,70 €
36_999	98006	Spoke Ballance weight, 10gr	1,26 €	1,50 €
36_999	98000	Wheel balance weight to clue on, 45gr, divisible for casted rim, 10gr and 5gr division	2,61 €	3,10 €
36_999	98491	Mounting spring for balance weight	0,67 €	0,80 €
36_999	98008	Spokes ballance weight, 20gr	1,34 €	1,60 €
36_999	98007	Spokes ballance weight, 15gr	1,34 €	1,60 €
36_999	1452727	Spoke nipple M4 for BMW R80R/100R and R80GS/R100GS/R80GS Basic from 1987 short spoke wheel	1,76 €	2,10 €
36_999	1242943	Wheel balancing weight 05gr	1,93 €	2,30 €



Group 46a Frame, fenders, baggage carrier

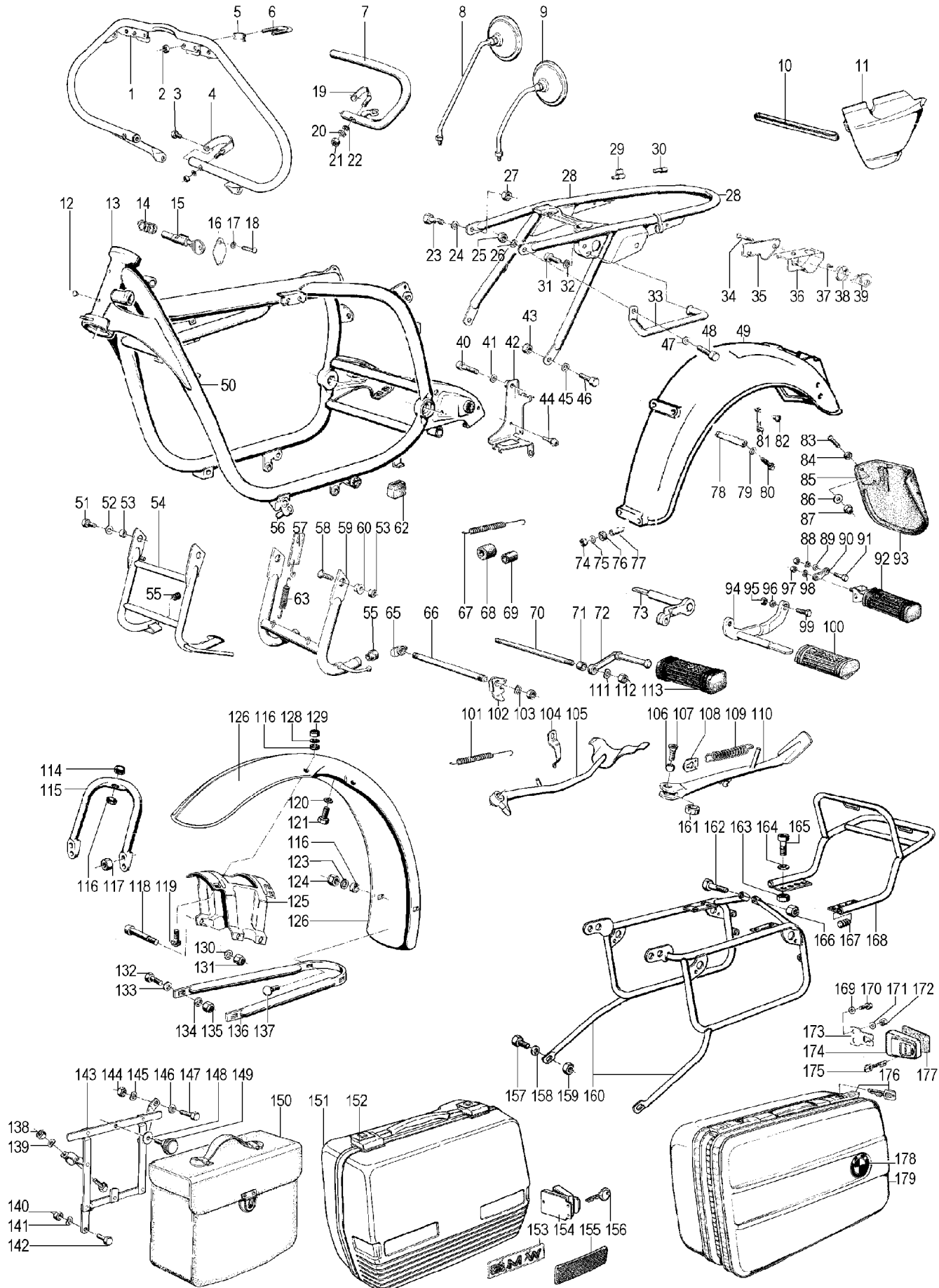

Picture-No. Article-No. Description

46_000 1451237 Footrest bolt for BMW R65GS-R100PD from year of manufacture 11/1986, rear

Net Gross
6,05 € 7,20 €



46_000	7770005	Sticker "Reifendruck" below dual seat for BMW R50/5 and up Reifendruck = tire inflation pressure	4,79 €	5,70 €
46_012	1235463	Identification plate for BMW R60/7 and R60TIC, 599cm ³	4,12 €	4,90 €
46_012	1235440	Identification plate for BMW R100S, 980cm ³	8,74 €	10,40 €
46_999	1452444	Grommet for impact plate for BMW R65, R80, R80RT and R100RT	0,67 €	0,80 €
46a_00	0903914	Rear Mirror for BMW R45, R65 and R100/7 years of manufacture 1981-1984, long, right side 8mm, black, reduced display	17,23 €	20,50 €
46a_000	1238292	Angle-bolt side stand for BMW R45 and R65 until year of manufacture 09/1980	1,76 €	2,10 €
46a_000	34861	Tire air pump for BMW models from R50/5 und up, short silver	15,88 €	18,90 €
46a_000	1457390	Foot rest bearing bracket for BMW R65-R100PD from year of manufacture 11/1986	1,85 €	2,20 €
46a_000	1457392	Footrest stop for BMW R65-R100PD	1,01 €	1,20 €
46a_000	1455735	Paint pen / touch up applicator set, columbia-silvermetallic for BMW K100 REMNANTS	8,57 €	10,20 €
46a_000	1233574	Headlight clamp (full fairing)	2,02 €	2,40 €
46a_000	2302079	Crash bar clamp, split version / half, black ONLY in combination with article #2302080	5,04 €	6,00 €
46a_000	2302080	Crash bar mount, split version / half, black ONLY in combination with article #2302079	3,95 €	4,70 €
46a_000	1452297	Dust cover seat-lock for BMW R60/7-R100, years of manufacture 1976-1984	1,93 €	2,30 €
46a_000	9056257	Center stand for BMW R45 and R65 until year of manufacture 01/1982, "1st version"	97,48 €	116,00 €
46a_000	1239070	Bushing side stand for BMW R45 and R65 until year of manufacture 09/1980 in holder	0,42 €	0,50 €
46a_000	1242204	Battery cover lateral for BMW R65GS, R80G/S and R80ST, right side grounded	74,71 €	88,90 €
46a_000	112520	Rear Mirror "Albert", left side	39,33 €	46,80 €
46a_000	112521	Rear Mirror "Albert", right side	39,33 €	46,80 €
46a_000	2301594	Center stand for BMW R45 and R65 from year of manufacture 02/1982	127,73 €	152,00 €
46a_000	38294	Retaining bracket for side stand for BMW R45 and R65	3,53 €	4,20 €
46a_000	90172	Dust cap for tire air pump	0,59 €	0,70 €
46a_000	90176	Rubber gasket for tire air pump	1,18 €	1,40 €
46a_000	90170	Tire air pump valve breather	0,76 €	0,90 €
46a_000	90174	Rubber back-pressure valve for tire air pump	0,50 €	0,60 €
46a_000	13070	Varnish pen, black	9,33 €	11,10 €
46a_000	1454535	Foot rest for BMW R65-R100PD, left side, rear	35,46 €	42,20 €
46a_000	1236606	Brake hose holder from BMW R75/6 in connection with guard bracket (crashbar)	1,76 €	2,10 €
46a_000	35469	Key for "Krauser" bag (old Touring K1 systems)	15,46 €	18,40 €
46a_000	2300045	Emblem Integral-case and System-case stick-on label, original BMW	9,16 €	10,90 €
46a_000	34860	Tire air pump for BMW models from R50/5 und up, short black	15,88 €	18,90 €
46a_000	2302102	Battery cover lateral for BMW R80ST, left grounded	97,48 €	116,00 €
46a_000	2323569	"Sticker for BMW ""BOXER"" left side" silver	34,29 €	40,80 €
46a_000	2323570	"Sticker for BMW ""BOXER"" right side" silver	34,29 €	40,80 €
46a_000	2300039	Hinge for City pannier	4,71 €	5,60 €
46a_000	2303652	Bag carrier lock for City case	17,23 €	20,50 €
46a_000	2307385	Headlight bracket cover for BMW R80R-R100R, left side primed	40,17 €	47,80 €
46a_000	2307386	Headlight bracket cover for BMW R80R-R100R, right side primed	31,93 €	38,00 €
46a_000	1242203	Battery cover lateral for BMW R65GS und R80G/S, left side grounded	84,79 €	100,90 €
46a_000	0504014	Rear Mirror for BMW R60/6-R100, long, right side 8mm, chrome-plated, reduced display	18,15 €	21,60 €
46a_000	0804012	Rear Mirror for BMW R60/6-R100, short, right side 8mm, reduced display, REMNANTS	17,23 €	20,50 €
46a_000	0803913	Rear Mirror for BMW R60/6-R100 and R45, R65, short, left side 8mm, reduced display	17,23 €	20,50 €
46a_000	0503913	Rear Mirror for BMW R60/6-R100, long, left side 8mm, chrome-plated, reduced display	18,15 €	21,60 €
46a_000	7770002	Sticker "Inspektion" for BMW all models /5	5,63 €	6,70 €
46a_000	3308039	Rear Mirror for BMW R60/6-R100 and R45, R65, R80G/S, short, left side 8mm, black, normal display	20,76 €	24,70 €
46a_000	3308040	Rear Mirror for BMW R60/6-R100 and R45, R65, R80G/S, short, right side 8mm, black, normal display	20,76 €	24,70 €
46a_001	9024171	Crash bar for BMW R50/5-R100 until year of manufacture 09/1980, trapeze shape, chrome complete with mounting parts	173,03 €	205,90 €
46a_004	1237759	Crash bar clamp, one piece, black for original BMW crash bar	11,18 €	13,30 €
46a_006	24186	Crash bar U-mounting clamp for BMW R50-R69S	7,14 €	8,50 €
46a_007	2303890	Crash bar for BMW R80GS, R100GS and R80GS Basic from year of manufacture 1987, right side, black for oil cooler mounting	93,36 €	111,10 €
46a_007	2301820	Crash bar for BMW R45, R65 and R65LS, right side chrome, original BMW	89,08 €	106,00 €
46a_007	3052	Crash bar set for BMW R50/5-R100CS, R80/100GS, ST, Fehling, chrome 2 parts, with mounting-material	153,28 €	182,40 €
46a_007	2301818	Crash bar for BMW R60/7-R100 and R65GS-R80GS, right side, black	93,45 €	111,20 €
46a_007c	1240879	Crash bar for BMW R60/7-R100 and R45T, R65T until year of manufacture 1985, left side, chromed	202,94 €	241,50 €



46a_007d	01808	Crash bar for BMW R60/7-R100, R45T-R65T until 09/1984, right side, chromed and for BMW R80/100R, R80GS Basic	202,94 €	241,50 €
46a_007h	1242628	Crash bar for BMW R65GS-R100PD, left side, black with sidestand-mounting point	160,34 €	190,80 €
46a_008	6039	Rear Mirror for BMW, oval, for bar end mounting, left side	19,83 €	23,60 €
46a_008	1453078	Rear Mirror for BMW R80GS-R100R and R100GS/PD year of manufacture 1991-95, left + right side black	43,11 €	51,30 €
46a_008	2316125	Rear Mirror for BMW R80GS-R100R, left + right side chrome-plated	53,28 €	63,40 €
46a_008	0006039	Rear Mirror for BMW, oval, for bar end mounting, right side	19,83 €	23,60 €
46a_008a	2039	Rear Mirror for BMW R50/5, R60/5 and R75/5, long, left side 10mm left-hand thread, 10mm bar	36,05 €	42,90 €
46a_008b	2046	Rear Mirror for BMW R50/5, R60/5 and R75/5, long, right side 10mm right-hand tread, 10mm bar	33,70 €	40,10 €
46a_008c	5039	Rear Mirror für BMW R60/6-R100 and R45, R65, long, left side chromed	21,93 €	26,10 €
46a_008d	5040	Rear Mirror for BMW R60/6-R100, long, right side 8mm	17,23 €	20,50 €
46a_008e	2055	Rear Mirror for BMW R60/6-R100 and R45, R65, long, left side black	21,93 €	26,10 €
46a_008f	2056	Rear Mirror for BMW R60/6-R100, long, right side black	21,93 €	26,10 €
46a_008g	9039	Rear Mirror for BMW R45, R65 and R65LS, right side, long 8mm	21,93 €	26,10 €
46a_008g	0903912	Rear Mirror for BMW R45, R65 and R100/7 years of manufacture 1981-1984, long, right side 8mm, chrome-plated, reduced display	17,23 €	20,50 €
46a_009a	2041	Rear Mirror for BMW R50/5, R60/5 and R75/5, short, left side 10mm, left-hand thread	32,86 €	39,10 €
46a_009c	8039	Rear Mirror for BMW R60/6-R100 and R45, R65, short, left side 8mm thread	17,23 €	20,50 €
46a_009c	2308039	Rear Mirror for BMW R60/6-R100 and R45, R65, R80GS, short, left side 8mm, black, reduced display	20,76 €	24,70 €
46a_009d	8040	Rear Mirror for BMW R60/6-R100, short, right side 8mm	17,23 €	20,50 €
46a_009d	2308040	Rear Mirror for BMW R60/6-R100/7, short, right side 8mm, black, reduced display	22,35 €	26,60 €
46a_009e	9040	Rear Mirror for BMW R45, R65 and R65LS, short, right side 8mm	17,23 €	20,50 €
46a_009f	02175	Rear Mirror for BMW R65 and R80 from year of manufacture 09/1984, short, left + right side black, R100GS, PD until year of manufacture 1990	17,23 €	20,50 €
46a_009f	021751	Rear Mirror for BMW R65 and R80 from year of manufacture 09/1984, long, left + right side black	20,08 €	23,90 €
46a_009f	0804111	Rear Mirror for BMW R45, R65 and R100/7 years of manufacture 1981-1984, short, right side 8mm, chrome-plated, reduced display	20,76 €	24,70 €
46a_009g	98369	Nut M10 for rear mirror, left-hand thread for BMW R50/5, R60/5 and R75/5	0,84 €	1,00 €
46a_009h	6040	Rear Mirror for BMW, round, for bar end mounting, left side	25,55 €	30,40 €
46a_009i	0006041	Rear Mirror for BMW, round, for bar end mounting, right side	19,08 €	22,70 €
46a_010	1351414	Batterie cover rubber ring for BMW R50/5-R100	2,18 €	2,60 €
46a_011	1233524	Rubber washer for battery cover for BMW R60/7-R100, 4,5mm	1,60 €	1,90 €
46a_011	1233525	Rubber washer for battery cover for BMW R60/7-R100, 11mm	1,18 €	1,40 €
46a_011	1452436	Battery cover lateral for BMW R65-R80RT from year of manufacture 09/1984, right side and R100 from year of manufacture 1987	43,11 €	51,30 €
46a_011	36510	Grommet batterie cover for BMW R45/R65 and R65GS-R80ST	2,44 €	2,90 €
46a_011	2307376	Battery cover lateral for BMW R80R-R100R, right side grounded	23,87 €	28,40 €
46a_011a	31867	Battery cover for BMW R50/5 until year of manufacture 08/1983, Set (2 pieces) stainless steel polished	119,41 €	142,10 €
46a_011b	1452486	Sticker for battery cover "R80RT", red/silver	11,85 €	14,10 €
46a_011c	2301027	Sticker for battery cover "R65", gold	17,14 €	20,40 €
46a_011d	1231862	Battery cover for BMW R50/5-R75/5 until year of manufacture 08/1973, left side chrome/black, Original BMW	171,09 €	203,60 €
46a_011e	1231863	Battery cover Battery cover for BMW R50/5-R75/5 until year of manufacture 08/1973, right chrome/black, original BMW	171,09 €	203,60 €
46a_011f	1237173	Battery cover for BMW R45 and R65 until year of manufacture 1984, left side unpainted, original BMW	38,24 €	45,50 €
46a_011g	1237174	Battery cover for BMW R45 and R65 until year of manufacture 1984, right side unpainted, Original BMW	42,94 €	51,10 €
46a_011h	1232539	Battery cover for BMW from year of manufacture 09/1973, left side unpainted	29,24 €	34,80 €
46a_011i	1235024	Battery cover for BMW from year of manufacture 09/1973, right side unpainted	29,24 €	34,80 €
46a_011k	1452435	Battery cover for BMW R65-R80RT from year of manufacture 09/1984, left side and R100 from year of manufacture 1987	49,83 €	59,30 €
46a_011k	36083	Sticker for battery cover "1000cc", gold	12,94 €	15,40 €
46a_011k	1234621	Sticker for battery cover "1000cc", silver	12,94 €	15,40 €
46a_011l	35655	Sticker for battery cover "1000cc", blue	12,94 €	15,40 €
46a_011m	34051	Sticker for battery cover "600cc", silver	12,94 €	15,40 €
46a_011n	33327	Sticker for battery cover "750cc", silver	12,94 €	15,40 €
46a_011na	1236082	Sticker for battery cover "750cc", gold	12,94 €	15,40 €
46a_011o	37266	Sticker for battery cover "800cc", silver	12,02 €	14,30 €
46a_011p	33328	Sticker for battery cover "900cc", silver	10,59 €	12,60 €
46a_011q	01020	Sticker for battery cover "R100RS", white	12,94 €	15,40 €
46a_011s	1240691	Sticker for battery cover "R80", gold	14,37 €	17,10 €
46a_011t	1240692	Sticker for battery cover "R80", white	14,37 €	17,10 €
46a_011v	1240001	Sticker for battery cover "R100/7", silver	6,64 €	7,90 €
46a_011w	1239098	Sticker for battery cover "R65", white	13,53 €	16,10 €



46a_011w	2301025	Sticker for battery cover "R65", silver	12,94 €	15,40 €
46a_011x	1240006	Sticker for battery cover "R80/7", gold	18,74 €	22,30 €
46a_011y	1240008	Sticker for battery cover "R100S", silver	12,94 €	15,40 €
46a_011z	1239097	Sticker for battery cover "R45", white	19,83 €	23,60 €
46a_012	36624	Groove pin for ID-plate for BMW R50/5-R90S stainless steel	0,59 €	0,70 €
46a_012	31086	Identification plate for BMW R60/5	8,57 €	10,20 €
46a_012	31087	Identification plate for BMW R75/5	8,57 €	10,20 €
46a_012	31085	Identification plate for BMW R50/5	7,14 €	8,50 €
46a_014	16104	Lock spring for steering lock	1,09 €	1,30 €
46a_015a	9016007	Steering lock for BMW R50/5, R60/5 and R75/5 original BMW	61,43 €	73,10 €
46a_015a	317025	Steering lock for BMW R25/3-R27, R50-R69S and R50/5-R100, short	10,25 €	12,20 €
46a_015b	1243274	Steering lock for BMW R60/6-R100RS/GS original BMW	46,13 €	54,90 €
46a_017	32019	Spring washer for steering lock cover for BMW R25/3-R27 and R50-R100	0,25 €	0,30 €
46a_018	92025	Groove pin for steering-lock cover and stepshield for BMW R26, R27 and R50-R100/7	0,50 €	0,60 €
46a_023	1231093	Screw for frame tail mount for BMW R50/5-R100, long wheel base	1,60 €	1,90 €
46a_028a	01268	Frame rear end for BMW, long wheel base used	129,75 €	154,40 €
46a_030	35638	Bolt for dual seat holder for BMW R50/5 and up to weld on frame	11,18 €	13,30 €
46a_033	1234637	Handle from rear frame for BMW R50/5-R100RT until yer of manufacture 1995 black	24,71 €	29,40 €
46a_034	28562	Screw for seat-lock for BMW R50/5-R100 stainless stell	0,59 €	0,70 €
46a_035	30194	Lock plate for dual seat for BMW R50/5-R100	4,54 €	5,40 €
46a_036	30186	Lock for dual seat for BMW R50/5-R100	43,11 €	51,30 €
46a_037	07602	Screw for lock cylinder seat for BMW R50/5-R100 M 3 x 8	1,34 €	1,60 €
46a_038	09932	Ring for dual seat lock for BMW R45, R65 and R50/5-R100	3,28 €	3,90 €
46a_039	1243651	Lock toolbox for BMW R45/R65 and late GS/PD-models	36,39 €	43,30 €
46a_039	43277	Lock cylinder for dual seat lock for BMW R45, R65 and R50/5-R100 with 2 keys	78,40 €	93,30 €
46a_044	1231084	Rubber buffer for battery bracket for BMW from R50/5 and higher, short wing base and headlight from R60/6 and higher	2,44 €	2,90 €
46a_046	1231093	Screw for frame tail mount for BMW R50/5-R100, long wheel base	1,60 €	1,90 €
46a_048	1231093	Screw for frame tail mount for BMW R50/5-R100, long wheel base	1,60 €	1,90 €
46a_049a	1240297	Fender for BMW R50/5, rear, until year of manufacture 09/1980 ground coat (black-matte), original BMW New-part	129,75 €	154,40 €
46a_049b	295001	Fender for BMW R50/5, rear, until year of manufacture 09/1980 black painted and lined, original BMW new part	304,71 €	362,60 €
46a_049c	1242635	Fender for BMW R65GS, R80G/S and R80ST, rear, from year of manufacture 1980-1992 black, plastic, original BMW new part	71,09 €	84,60 €
46a_051	35511	Holding screw center stand for BMW R50/5-R100 until year of manufacture 09/1980	1,51 €	1,80 €
46a_053	2302049	Nut M10 center stand for BMW BMW R45/R65 and R60/7-R100 until year of manufacture 09/1984 self-locking	1,60 €	1,90 €
46a_053a	30210	Center stand bushing for BMW R50/5-R100 until year of manufacture 09/1980	6,05 €	7,20 €
46a_053c	01704	Center stand bushing for BMW R45/R65 and R60/7-R100	2,61 €	3,10 €
46a_054	1234757	Center stand for BMW R50/5-R100 until year of manufacture 09/1980, 2 brace	120,59 €	143,50 €
46a_055	36522	Rubber plug for center stand for BMW R50/5-R100 and side stand stop for BMW models from year of manufacture 1981	2,44 €	2,90 €
46a_056b	1231233	Bolt side stand for BMW R50/5 and up, oversize! must be adapted to drilling from frame and stand!	16,30 €	19,40 €
46a_056c	2311723	Bolt side stand at crashbar for BMW R65GS-R100GS, R80R and R100R retrofitting (replacement for screw)	5,63 €	6,70 €
46a_057	1238329	Center stand holder for BMW R45 and R65, /7-R100 from year of manufacture 09/1980	3,45 €	4,10 €
46a_058	02046	Holding screw center stand for BMW models from year of manufacture 09/1980, countersunk head and for BMW R45/R65 from year of manufacture 09/1978	2,18 €	2,60 €
46a_059	2301593	Center stand for BMW R80-R100 from year of manufacture 09/1980, 1 brace	129,75 €	154,40 €
46a_060	01704	Center stand bushing for BMW R45/R65 and R60/7-R100	2,61 €	3,10 €
46a_062	31815	Rubber bumper for center stand for BMW R50/5-R100	7,98 €	9,50 €
46a_063	2331805	Spring center stand for BMW R45/R65 and R60/7-R100R from year of manufacture 01/1982 and for BMW R80/R100GS, 111mm (in connection with retaining bracket articelnr.: 1238329)	4,96 €	5,90 €
46a_063	01583	Spring center stand for BMW R45/R65 and R60/7-R100R from year of manufacture 01/1982 and for BMW R80/R100GS, 143mm (WITHOUT retaining bracket)	4,96 €	5,90 €
46a_063	36282	Spring center stand for BMW R45/R65 and R60/7-R100 until year of manufacture 01/1982	4,54 €	5,40 €
46a_065	30409	Center stand holder for BMW R50/5 from year of manufacture 09/1980, right side	3,95 €	4,70 €
46a_066	30762	Engine axle for BMW R50/5-100, front and for BMW R45/R65 from year of manufacture 1981, also rear	20,00 €	23,80 €
46a_066	2311725	Engine axle for BMW R50/5-100, front and for BMW R45/R65 from year of manufacture 1981, ONLY for crash bar using - 315mm	17,23 €	20,50 €
46a_067	34514	Spring center stand for BMW R50/5-R100 until year of manufacture 09/1980	2,44 €	2,90 €
46a_068	1237787	Protection rubber for spring center stand for BMW R50/5-R100 from 09/1980, big	2,35 €	2,80 €



46a_069	1237786	Protection rubber for spring center stand for BMW R50/5-R100 until 09/1980, small	2,18 €	2,60 €
46a_070	30475	Engine axle for BMW R50/5-100, rear, years of manufacture 09/1969-09/1980 327mm	22,61 €	26,90 €
46a_071	2311726	Distance ring engine for BMW Models from year of manufacture 09/1969 until 08/1980	6,47 €	7,70 €
46a_072a	9034125	Foot rest driver for BMW R50-69S and R50/5-R100, left side	25,88 €	30,80 €
46a_072b	4034260	Foot rest for BMW R50-R69S and R50/5-R100, right side	38,32 €	45,60 €
46a_072c	1242017	Foot rest driver for BMW GS- and PD models, left side	50,84 €	60,50 €
46a_072d	1242018	Foot rest driver for BMW GS- and PD models, right side	50,84 €	60,50 €
46a_072e	1236733	Foot rest for BMW R60/7-R100S from 1977-1984, left side 90mm	25,88 €	30,80 €
46a_077	1232948	Spacer pipe rear fender for BMW R50/5, R60/5 and R75/5	3,70 €	4,40 €
46a_090	1232230	Footrest holder passenger for BMW-models from year of manufacture 09/1973	26,64 €	31,70 €
46a_092a	1230477	Foot rest passenger, flip-up, round, Denfeld also for G/S models, right side	21,34 €	25,40 €
46a_092b	1234661	Foot rest passenger, flip-up, square shape, BMW	53,61 €	63,80 €
46a_092c	1242700	Foot rest passenger for BMW R80G/S, flip-up, left side	40,59 €	48,30 €
46a_093	1230766	Rear mud flap for BMW R50/5-R100 until year of manufacture 09/1980	49,92 €	59,40 €
46a_099	9901064	Screw for mounting foot rest from 1980 and up, M10 x 35, cylinder head-Allen® key, flat	1,34 €	1,60 €
46a_099	9901106	Screw for mounting foot rest from 1980 and up, M10 x 50, Allen® key	1,51 €	1,80 €
46a_100a	1242046	Footrest rubber for BMW R45/R65 and R80-R100 until year of manufacture 08/1984, front	10,76 €	12,80 €
46a_100b	1454887	Footrest rubber for BMW R65-R100 from year of manufacture 09/1984	7,82 €	9,30 €
46a_101a	30219	Spring side stand for BMW R50/5, R60/5 and R75/5 until year of manufacture 09/1971	4,20 €	5,00 €
46a_101b	31646	Spring side stand for BMW R50/5-R100, years of manufacture 09/1971-09/1980	4,96 €	5,90 €
46a_102	41597	Retaining strap for side stand for BMW R50/5-R100 until year of manufacture 09/1980	24,12 €	28,70 €
46a_104	1236859	U-bolt for side stand spring for BMW R50/5-R100, years 09/1969-09/1980	11,01 €	13,10 €
46a_105	1242949	Side stand for BMW R65GS, R80G/S and R80ST until year of manufacture 1987 crash bar mounting	95,13 €	113,20 €
46a_105	1454673	Side stand for BMW R65RT SF, R80, R80RT, R100RT und R100RS from year of manufacture 1985	112,44 €	133,80 €
46a_105a	41598	Side stand for BMW R50/5-R100 until year of manufacture 09/1980	187,56 €	223,20 €
46a_105b	41599	Side stand for BMW R50/5 until year of manufacture 09/1980 used – please indicate type and year manufacture!!!	69,16 €	82,30 €
46a_107	41170	Screw side stand for BMW R45, R65 and R80/7-R100	0,84 €	1,00 €
46a_107a	40465	Bolt side stand for BMW R45 and R65 years of manufacture 11/1979-09/1980	1,76 €	2,10 €
46a_108b	2310721	Retraining bracket for side stand spring for BMW models from year of manufacture 09/1984	1,18 €	1,40 €
46a_108c	2311722	Spring holder for side stand on crash bar for BMW R65GS-R100GS, R80R and R100R retrofitting	4,29 €	5,10 €
46a_108c	2302005	Spring holder for side stand for BMW R45-R100 from year of manufacture 09/1980	3,28 €	3,90 €
46a_109	1238290	Spring side stand for BMW R45 and R65 until year of manufacture 09/1980	15,21 €	18,10 €
46a_109	1236282	Spring side stand for BMW R65GS-R100GS, R80R and R100R until year of manufacture 1996 mount on crashbar	3,28 €	3,90 €
46a_109a	42335	Spring side stand spring for BMW R60/7-R100/7, R80RT-R100RT and for BMW R45/R65 from year of manufacture 09/1980	3,45 €	4,10 €
46a_109b	2310739	Spring side stand spring for BMW R65-R100RT from year of manufacture 09/1984	5,13 €	6,10 €
46a_110	2311720	Side stand for BMW R80GS, R100GS and R80GS Basic until year of manufacture 1988 crash bar mounting, black	95,13 €	113,20 €
46a_110b	1454750	Side stand for BMW R60/7-R100 years of manufacture 09/1980-09/1984 complete with attachment parts, reinforced	225,29 €	268,10 €
46a_110ba	1454741	Side stand for BMW R60/7-R100 years of manufacture 09/1980-09/1984 WITHOUT attachment parts, reinforced	124,54 €	148,20 €
46a_113	34107	Footrest rubber for BMW R25-R90/6, round/stiff	6,05 €	7,20 €
46a_113b	1234660	Footrest rubber from BMW R60/7 and up, square shape	13,87 €	16,50 €
46a_115	1230377	Fork stabilizer for BMW R50/5, R60/5 and R75/5 ONLY BY CUSTOMER REQUIREMENT	154,96 €	184,40 €
46a_116	1230798	Spacer rubber for fender brace	1,01 €	1,20 €
46a_119	9910408	Screw for front fender mount for BMW /5 and up, M 6 x 16	0,84 €	1,00 €
46a_119	98170	Screw M 6 x 16, cylinder-head Allen® key, flat	0,25 €	0,30 €
46A_125	1234907	Fork stabilisator for BMW R60/6-R100RS, years of manufacture 09/1973-09/1980	62,69 €	74,60 €
46A_125a	1241660	Fork stabilisator for BMW-models from year of manufacture 09/1980	33,70 €	40,10 €
46a_126a	1234935	Fender for BMW R50/5-R90/6, front (Mudguard) ground coat, original BMW new part	203,53 €	242,20 €
46a_126b	1235071	Fender for BMW R50/5-R60/7, front (Mudguard) painted and lined, extra long, "office model", original BMW new part, - please request for color!	302,86 €	360,40 €
46a_126b	4661935	Fender for BMW R50/5-R90/6, front (Mudguard) ground coat, replica	129,75 €	154,40 €
46a_126c	1234936	Fender for BMW R50/5-R90/6, front (Mudguard) painted and lined, original BMW new part - please request for color!	276,97 €	329,60 €
46a_126d	1237062	Fender for BMW R45, R65 and R80ST, front (Mudguard) Fender for BMW R45, R65 and R80ST, front (Mudguard)	142,77 €	169,90 €



46a_126e	1234931	Fender for BMW R90S and R60/7-R100RT, front (Mudguard), from year of manufacture 1976 ground coat, original BMW new part	129,75 €	154,40 €
46a_136	0032975	Fender brace for BMW R50/5-R90S, front bottom stainless steel	49,33 €	58,70 €
46a_142	98202	Screw M 8 x 25, hexagon	0,17 €	0,20 €
46a_143a	1237249	Leather bag carrier for BMW R45, R45T, R65 and R65T, left side	43,19 €	51,40 €
46a_143b	1237250	Leather bag carrier for BMW R45, R45T, R65 and R65T, right side	43,19 €	51,40 €
46a_149	1231263	Knurled screw for leather bag for BMW R50/5 and higher	1,68 €	2,00 €
46a_150a	0003858	Leather bag carrier set for BMW R50/5, R60/5 and R75/5, black for leather bag "Nostalgie" & "Classic", ONLY in connection with bag carrier for Krauser bags!	95,13 €	113,20 €
46a_150b	0003920	Leather bag fixing screw (knurled-head screw) for leather bag "Nostalgie" & "Classic"	6,89 €	8,20 €
46a_151c	2300009	Case-cover lock for older "Touring"- case	23,95 €	28,50 €
46a_153	1239455	Emblem "BMW" for Touring-case adhesive	21,26 €	25,30 €
46a_154	2300008	Bag carrier lock for older "Touring" case until year of manufacture 04/1989 new version, WITHOUT lock cylinder	30,50 €	36,30 €
46a_154a	2303680	Lock cylinder for bag carrier lock article nr. 2300008 with 2 keys	28,15 €	33,50 €
46a_155	1244529	Side reflector yellow, fork for BMW R45-R100 and for touring bags until year of manufacture 09/1984	6,55 €	7,80 €
46a_156	2300006	Key for "Touring" bag	2,61 €	3,10 €
46a_157	98157	Screw M 6 x 20, hexagon	0,17 €	0,20 €
46a_16	2025	Distributor baseplate for BMW R51/2 WITH contact-breaker lateral inversion	2,44 €	2,90 €
46a_160	650604	Bag carrier Set with bridge for BMW R45 and R65 until year of manufacture 1985, Hepco & Becker chrome	242,27 €	288,30 €
46a_160	650614	Bag carrier Set for BMW R80R and R100R, from year of manufacture 1992, Hepco & Becker black	133,95 €	159,40 €
46a_160a	1234597	Bag carrier Set for BMW R50/5, R65/5 and R75/5, short wheel base chrome	195,88 €	233,10 €
46a_160b	1239487	Bag carrier Set for BMW R50/5-R100 until year of manufacture 09/1984, long wheel base chrome	195,88 €	233,10 €
46a_160d	1239488	Bag carrier Set for BMW R45 and R65 until year of manufacture 1985 Chrome, original BMW	252,61 €	300,60 €
46a_160e	2300484	Bag carrier for BMW R65-R80RT from 1985 and R100 from 1987, right side chromed	80,42 €	95,70 €
46a_160f	2303529	Bag carrier Set (Integral-bags) for BMW R65-100RS from year of manufacture 1985	168,57 €	200,60 €
46a_161	42332	Bushing side stand for BMW R60/7-R100 and R45/R65 from year of manufacture 09/1980	14,37 €	17,10 €
46a_161a	41169	Bushing side stand for BMW R45 and R65 years of manufacture 11/1979-19/1980 in stand	3,45 €	4,10 €
46a_162	98179	Screw M 6 x 45, hexagon with shaft	0,25 €	0,30 €
46a_168	6140101	Baggage bridge for BMW R100R, Hepco & Becker black	96,81 €	115,20 €
46a_168	9056251	Luggage rack for BMW R65GS and R80GS, years of manufacture 1980-1986 black	89,08 €	106,00 €
46a_168a	1234693	Luggage rack for BMW R50/5-R100, until year 09/1984, with bag carrier article 1239487 or 1234597 chrom	118,24 €	140,70 €
46a_168c	2303693	Top case Classic 30 liters	154,96 €	184,40 €
46a_16a	1453158	Steering lock cover for BMW R65-R100RT from year of manufacture 09/1984	2,44 €	2,90 €
46a_173	700024	Bag carrier modification set for Hepco & Becker bags on-to BMW carriers	23,28 €	27,70 €
46a_173	35467	Retaining plate for Krauser bag	10,67 €	12,70 €
46a_174	700101	Bag carrier lock, Hepco & Becker	25,88 €	30,80 €
46a_174a	90106	Bag carrier lock Krauser K1 and K2 (1 pc.) If its for K1, you must drill an additional hole in the case.	57,31 €	68,20 €
46a_179	10010	Case hinge from Hepco & Becker for trunk 610.009	5,04 €	6,00 €
46a_179	70114	Case mounting plate from Hepco & Becker	8,24 €	9,80 €
46a_179a	9500001	Bag Set, Krauser-Classic für BMW R50/5-R100/7 until year of manufacture 09/1984 30 liter indent for passenger's hands, Improved version	380,08 €	452,30 €
46a_179e	1239269	Inner bag for Classic case, left side	51,93 €	61,80 €
46a_179e	9239269	Inner bag for Classic case, right side	51,93 €	61,80 €
46a_999	1233662	Identification plate for BMW R90/6	10,50 €	12,50 €
46a_999	1454536	Foot rest for BMW R65-R100PD, right side, rear	35,46 €	42,20 €
46a_999	1454388	Footrest washer for BMW R65-R100PD	1,51 €	1,80 €
46a_999	1242001	Screw for rear frame for BMW R50/5, R60/5 and R75/5, countersunk head	1,34 €	1,60 €
46a_999	37523	Side stand stop for BMW R45, R65 und R60/7-R80RT from year of manufacture 1979	0,50 €	0,60 €
46a_999	34511	Clamp bracket for Krauser pannier	11,18 €	13,30 €
46a_999	700110	Key for Hepco & Becker pannier please indicate key number	5,80 €	6,90 €
46a_999	2312791	Identification plate "plain" for BMW R45/R65 and R60/6-R100	20,92 €	24,90 €
46a_999	1236240	Grommet front panel for BMW R45 and R65 and battery cover for BMW R80ST, R80ST, R80GS and R100GS	1,43 €	1,70 €



Group 46b Fairing

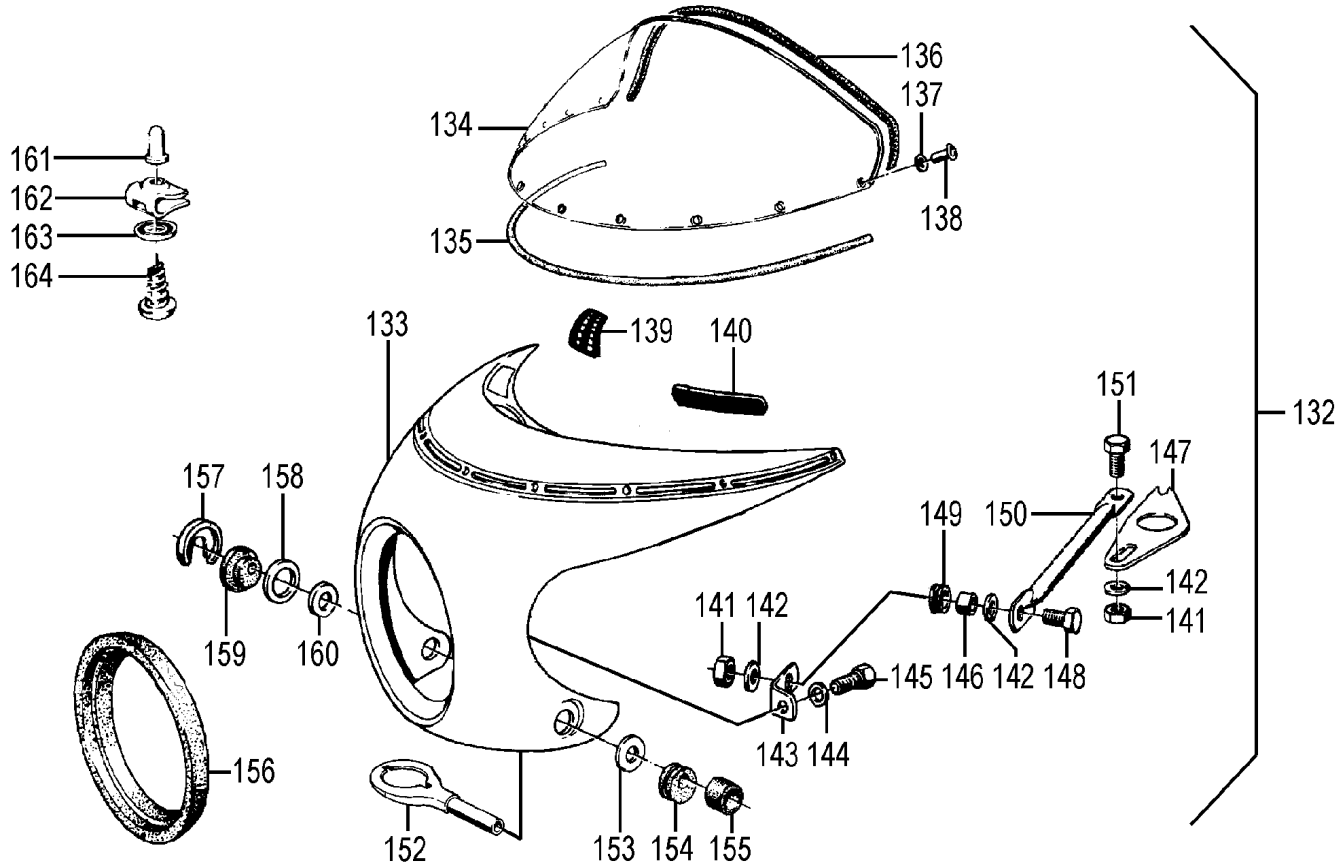

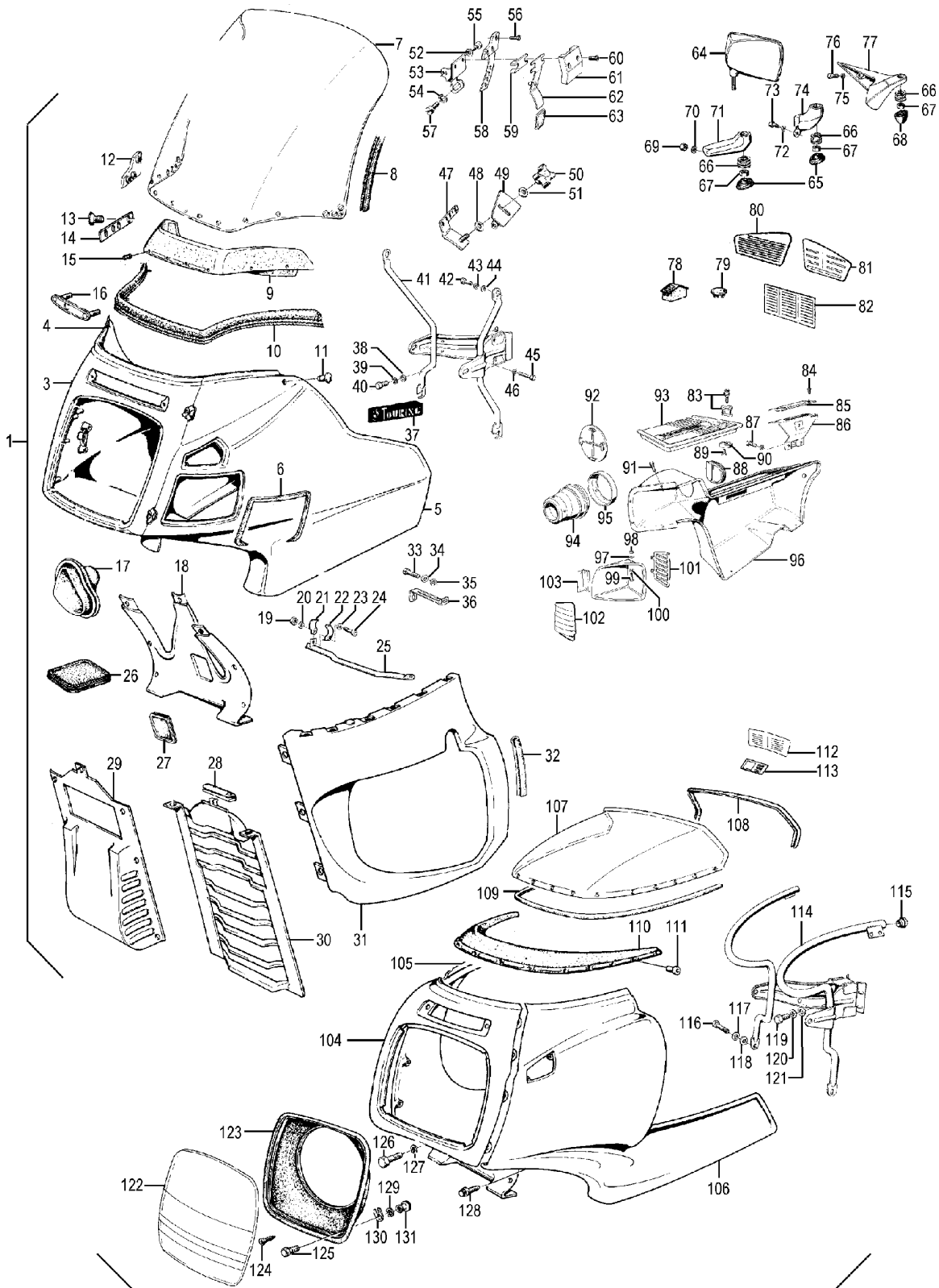

2

<u>Picture-No.</u>	<u>Article-No.</u>	<u>Description</u>	<u>Net</u>	<u>Gross</u>
46b_000	2325201	Emblem covering for BMW R100RT and R100T until year of manufacture 1984	7,14 €	8,50 €
46b_000	1239744	Cap for rear mirror cap for BMW R100RT until year of manufacture 09/1980, right side	1,34 €	1,60 €
46b_000	2303895	Support for windshield for BMW R65GS-R80ST, R80GS-R100PD and R80GS Basic	4,54 €	5,40 €
46b_000	2315099	Rubber bearing for BMW R80GS-R100PD, headlight cover	3,45 €	4,10 €
46b_000	2303902	Windshield for BMW R65GS-R100GS until year of manufacture 1990 primed	110,17 €	131,10 €
46b_006	1239021	Gasket for air-inlet RT-fairing	6,89 €	8,20 €
46b_006a	1238888	Grate RT fairing, right	3,11 €	3,70 €



46b_006b	1238887	Grate RT fairing, left	3,11 €	3,70 €
46b_007	37774	"Windshield for BMW ""RT"" - fairing until year of manufacture 12/1979" original BMW	212,10 €	252,40 €
46b_007	52480	"Windshield for BMW ""RT"" - fairing from year of manufacture 01/1980" original BMW	287,39 €	342,00 €
46b_007	40622	"Windshield for BMW ""RT"" - fairing, Speed 7"	142,02 €	169,00 €
46b_008	02180	Windshield edge protection for BMW "T" and "RT" - fairing	8,74 €	10,40 €
46b_009	1237773	Dashboard for BMW R65RT-R100RT fairing instruments not included	22,18 €	26,40 €
46b_010	1240649	Windshield gasket for BMW R45T-R100RT	29,41 €	35,00 €
46b_012	1241027	"Windshield clamp plate for BMW ""T"" and ""RT"" - fairing, left side until year of manufacture 12/1	5,46 €	6,50 €
46b_012	1241028	"Windshield clamp plate for BMW ""T"" and ""RT"" - fairing, right side, until year of manufacture 12	5,63 €	6,70 €
46b_015	49633	"Windshield rivet for BMW ""T"" and ""RT"" - fairing"	0,25 €	0,30 €
46b_016	1241031	"Windshield clamp plate for BMW ""T"" and ""RT"" - fairing, front, until year of manufacture 12/1984	16,72 €	19,90 €
46b_017a	35500	Fairing leg boot for BMW RS-, RT-models, left side	17,90 €	21,30 €
46b_017b	35501	Fairing leg boot for BMW RS-, RT-models, right side	17,90 €	21,30 €
46b_027	1235513	Gasket for BMW Models RS-, RT-fairing	3,78 €	4,50 €
46b_030	1238920	Fairing center part (engine) grounded	54,12 €	64,40 €
46b_030	9902497	Screw for fairing for BMW R100RS/RT and R45T/R65T	0,25 €	0,30 €
46b_037	1238975	Sticker "Touring" for fairing, golden	16,97 €	20,20 €
46b_053	1241171	"Windshield base plate for BMW ""T"" and ""RT"", left side until year of manufacture 12/1979"	4,45 €	5,30 €
46b_053	1241172	"Windshield base plate for BMW ""T"" and ""RT"", right side until year of manufacture 12/1979"	4,45 €	5,30 €
46b_058	1241023	"Windshield holder for BMW ""T"" and ""RT"", left side until year of manufacture 12/1979"	25,88 €	30,80 €
46b_058	1241024	"Windshield holder for BMW ""T"" and ""RT"", right side until year of manufacture 12/1979"	25,88 €	30,80 €
46b_062	1239552	"Windshield adjustor lever for BMW ""T"" and ""RT"", until year of manufacture 12/1979"	16,55 €	19,70 €
46b_064a	2302173	Rear Mirror for BMW R6RT-R100RT from year of manufacture 09/1984, left side convex	68,49 €	81,50 €
46b_064b	2302174	Rear Mirror for BMW R6RT-R100RT from year of manufacture 09/1984, right side convex	60,67 €	72,20 €
46b_064c	1241197	Rear Mirror head for BMW R60TIC-R100RS until year of manufacture 09/1984, left side convex	67,82 €	80,70 €
46b_064d	1241198	Rear Mirror head for BMW R60TIC-R100RS until year of manufacture 09/1984, right side	67,82 €	80,70 €
46b_065	1235568	Dust cap rear mirror base for BMW R100RS years of manufacture 09/1976-09/1984 and from 1987	1,68 €	2,00 €
46b_066	1235567	Mounting spring rear mirror for BMW all T-/RS-/RT-models	1,76 €	2,10 €
46b_067	98326	Nut M 6, self-locking zincked	0,17 €	0,20 €
46b_068	1240627	Cap for Rear Mirror for BMW T-/RT-Modells	3,28 €	3,90 €
46b_071a	1236129	Rear Mirror base for BMW R100RS years of manufacture 09/1976-09/1984 and from 1987, left side	31,09 €	37,00 €
46b_071b	1236130	Rear Mirror base for BMW R100RS years of manufacture 09/1976-09/1984 and from 1987, right side	31,09 €	37,00 €
46b_077a	1240623	Rear Mirror base for BMW R45RT-R100RT from year of manufacture 05/1980, left side	25,97 €	30,90 €
46b_077b	1240624	Rear Mirror base for BMW R45RT-R100RT from year of manufacture 05/1980, right side	25,97 €	30,90 €
46b_078	43644	Cover for Hazard warning light switch for BMW R60/6-R100 and R45/R65	13,61 €	16,20 €
46b_079	1238546	Sealing plug for instrument carrier for BMW RT and T-models Ø 21mm	2,61 €	3,10 €
46b_080	1239759	Sticker "Reifendruck", left side for BMW R45T, R65T, R65RT SF and R80-R100RT, Reifendruck = tire inflation pressure	7,14 €	8,50 €
46b_081	1239760	Sticker "Ölsorte Motor" on instrument panel right side for BMW R45, R65 and R80RT-R100RT, Ölsorte Motor = engine oil	7,14 €	8,50 €
46b_096	2307190	Gasket fairing side-box for all BMW T- and RT-Models, upper	14,96 €	17,80 €
46b_096	1239107	Gasket fairing side-box for all BMW RT-Models, lower	6,55 €	7,80 €
46b_100	1239143	Air-intake RT fairing, left side for all BMW models years of manufacture 1976-1995	40,59 €	48,30 €
46b_100	1239144	Air-intake RT fairing, right side for all BMW models years of manufacture 1976-1995	40,59 €	48,30 €
46b_107	35414	Windshield for BMW R100RS - fairing original BMW	139,58 €	166,10 €
46b_107	35415	Windshield for BMW R100RS - fairing, Speed 7	104,71 €	124,60 €
46b_109	35507	Windshield rubber seal for BMW R100RS - fairing	2,52 €	3,00 €
46b_110	1235405	Dashboard for BMW R100RS fairing instruments not included	31,09 €	37,00 €
46b_111	49632	"Windshield rivet for BMW ""S"" and ""RS"" - fairing"	0,50 €	0,60 €
46b_122	39110	Headlight lens for BMW all RT and RS fairings	47,23 €	56,20 €
46b_133	1233732	Cockpit "S" und "CS" - Fairing with dashboard, primed Original BMW	343,53 €	408,80 €
46b_133b	1233187	Cockpit "S" - Dashboard	29,66 €	35,30 €
46b_134	1235499	Windshield for BMW R90S and R100S - Cockpit original BMW	139,50 €	166,00 €



46b_134	35499	Windshield for BMW R90S and R100S - Cockpit, Speed 7	73,03 €	86,90 €
46b_134	9935499	"Windshield for BMW ""S"" Krauser" ONLY for Krauser-fairing, REMNANTS	66,47 €	79,10 €
46b_135	1233189	Windshield rubber seal for BMW R90S and R100S - fairing	2,69 €	3,20 €
46b_137	33166	Washer for windshield rivet for BMW S-, RS-, RT-Cockpit	1,18 €	1,40 €
46b_138	33909	"Windshield rivet for BMW ""S"", ""RS"", ""RT"", ""T"" and ""CS"" - fairing" plastic	1,09 €	1,30 €
46b_139	1233191	Sticker "Ölsorte Motor" in cockpit S for BMW R60/6-R90S, 1973/1974, right side Ölsorte Motor = engine oil	5,21 €	6,20 €
46b_139	1236236	Sticker "Ölsorte Motor" in cockpit for BMW R100S/R100CS/R100RS, right side Ölsorte Motor = engine oil	5,21 €	6,20 €
46b_140	1236235	Sticker "Zündkerzen - Reifendruck" for BMW Cockpit S, R60/6-R100CS, 1973/1974, left side Zündkerzen - Reifendruck = spark plug - tire inflation pressure Sticker "Reifendruck" in cockpit for BMW R100S/R100RS from year of manufacture 1975, left side and for BMW R45T, R65T, R65RT SF and R80RT-R100RT, Reifendruck = tire inflation	5,21 €	6,20 €
46b_140	1453085	Cockpit "S" - Nut M 6, self-locking	0,17 €	0,20 €
46b_141	9900191	Washer M 6, DIN125, Form A cined	0,08 €	0,10 €
46b_142	98410	Cockpit "S" - mounting bracket, black	9,08 €	10,80 €
46b_143	1240625	Lock washer A 6, Form B zincked	0,17 €	0,20 €
46b_144	98428	Screw M 6 x 10, hexagon	0,17 €	0,20 €
46b_145	98156	Cockpit "S" - Bushing for mounting strut	2,02 €	2,40 €
46b_146	1233253	Additional instrument mounting flap, black	5,97 €	7,10 €
46b_147	1240651	Grommet mounting strut for Cockpit "S"	1,51 €	1,80 €
46b_149	1233200	Cockpit "S" - Strud, black	25,88 €	30,80 €
46b_150	1240650	Screw for clutch 1-cylinder, also oilpump cover for BMW R60/6-R90S, M 6 x 16, hexagon	0,17 €	0,20 €
46b_151	98155	Indicator light holder for BMW R50/5-R100/7, front, chromed	33,87 €	40,30 €
46b_152	1233941	Cockpit "S" - Indicator light holder, front long version	47,06 €	56,00 €
46b_152	1233943	Cockpit "S" - mounting ring	5,97 €	7,10 €
46b_153	1233693	Cockpit "S" - mounting excentric rubber grommet	14,87 €	17,70 €
46b_154	1234406	Cockpit "S" - gasket for lamp	18,91 €	22,50 €
46b_156	1233186	Cockpit "S" - mounting cap	6,64 €	7,90 €
46b_157	1234405	Cockpit "S" - mounting rubber grommet	1,09 €	1,30 €
46b_158	1234407	Cockpit "S" - mounting excentric rubber grommet	14,87 €	17,70 €
46b_159	1234406	Cockpit "S" - mounting ring	5,97 €	7,10 €
46b_160	1233693	Mounting guidelines windshield for BMW R60/7-R100 until year of manufacture 09/1984 in GERMANY	3,27 €	3,50 €
46b_166	9796055	Wind deflector mounting set for BMW R65GS-R100GS for windshield 2303902	9,33 €	11,10 €
46b_999	9062391			



Group 52 Seat

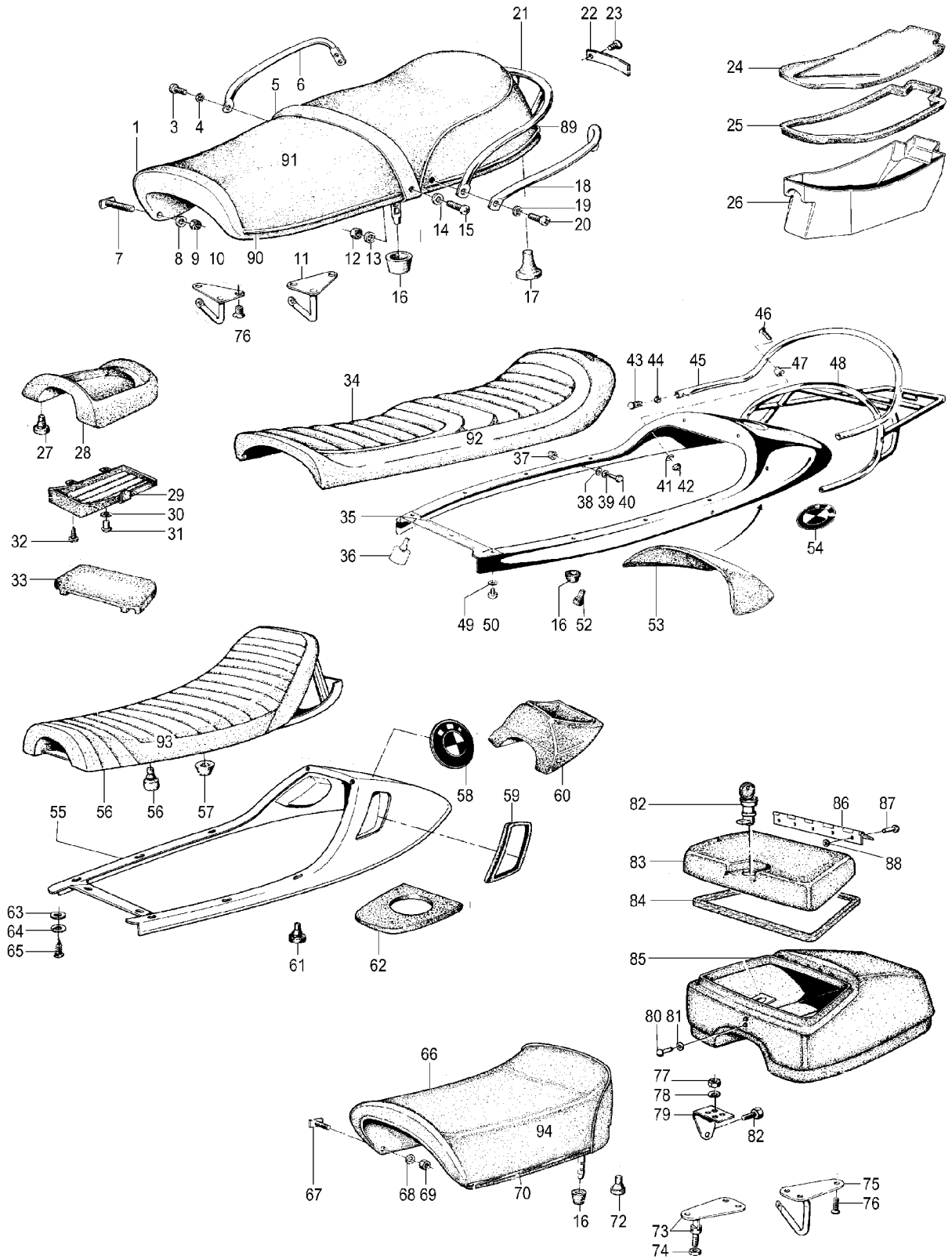

Picture-No.	Article-No.	Description	Net	Gross
52_000	1852347	Bump stop rubber for seat, tank and batterycover	5,21 €	6,20 €
52_000	115026	Dual seat with bump for BMW R50/5-R90/6, LWB Giullieri replica	198,24 €	235,90 €
52_000	34318	Safty clip dual seat for BMW R50/5-R100 and R45/R65	1,60 €	1,90 €
52_000	1452274	Cover for rear part seat bench for BMW R100RT, RS, R80 and R80RS	3,53 €	4,20 €
52_000	50252	Dual seat with bump for BMW R50/5, R60/5 and R75/5, shortwing base Giullieri replica	198,24 €	235,90 €
52_000	115025	Dual seat with bump for BMW R90S, R60/7-R100/7 and R45-R100, years of manufacture 1981-1995	215,46 €	256,40 €
52_001	39965	Dual seat for BMW R50/5, R60/5 and R75/5, long wheel base lenghtways pattern, with chrome rail, Reproduction	224,87 €	267,60 €



52_001	33962	Dual seat for BMW R50/5, R60/5 and R75/5 until year of manufacture 09/1971, short wheel base plain no pattern, with two chrome grips, Reproduction	221,68 €	263,80 €
52_001	33963	Dual seat for BMW R50/5, R60/5 and R75/5 from year of manufacture 09/1971, short wheel base lenghtways pattern, with one-piece chrome rail, Reproduction	224,87 €	267,60 €
52_001	71004	Dual seat cover for BMW R50/5, R60/5 and R75/5 until year of manufacture 09/1971, short wheel base plain	50,00 €	59,50 €
52_001	71006	Dual seat cover for BMW R60/7, R75/7, R80/7 and R100/7	50,92 €	60,60 €
52_001	30197	Dual seat for BMW R50/5, R60/5 and R75/5, short wheel base cross pattern, with one-piece chrome rail, original BMW	363,53 €	432,60 €
52_001	33960	Dual seat for BMW R50/5-R90/6, long wheel base cross pattern, with rail, original BMW	416,64 €	495,80 €
52_001	5003	Dual seat cover for BMW R50/5, R60/5 and R75/5 until year of manufacture 09/1971, short wheel base lenghtways pattern	58,40 €	69,50 €
52_001	33961	Dual seat for BMW R60/6, R75/6 and R90/6 cross pattern, with rail, Reproduction	224,87 €	267,60 €
52_001g	33964	Dual seat for BMW R60/7-R100/7 cross pattern, with rail, Reproduction	224,87 €	267,60 €
52_001h	37832	Dual seat for BMW R60/7-R100/7 cross ribbed pattern, with rail, original BMW	626,39 €	745,40 €
52_001k	71005	Dual seat cover for BMW R50/5-R90/6, long wheel base lenghtways pattern	55,55 €	66,10 €
52_001l	71003	Dual seat cover for BMW R50/5-R90/6, long wheel base cross pattern, black piping	55,55 €	66,10 €
52_003	9907639	Screw for seat grab handle for BMW /6-R100, M 5 x 10, raised countersunk head-crossed slot	1,01 €	1,20 €
52_006	30501	Dual seat bar pair for BMW R50/5, R60/5 and R75/5 until year of manufacture 09/1971 grab handles, ONLY for repro-dual seat (articlenr: 33962)	37,73 €	44,90 €
52_006b	1452420	Dual seat grab handle for BWM R65-R100 from year of manufacture 11/1986	25,88 €	30,80 €
52_007	99117	Screw-Set for trim strip dual-seat for BMW R50/5-R100/7	11,26 €	13,40 €
52_010	30314	Dual seat holder bracket for BMW R50/5-R90S, front	13,03 €	15,50 €
52_010	2530716	Dual seat holder bracket for BMW R60/7-R100RT, front	14,62 €	17,40 €
52_011	36351	Dual seat holder bracket for BMW R50/5-R100RT, RS, rear	13,03 €	15,50 €
52_011	1452425	Dual seat holder bracket for BMW R65, R65RT SF, R100RT and R100RS years 1985-1995, front and rear	13,78 €	16,40 €
52_016	30313	Buffer for dual seat lock pin for BMW R45, R65 and R50/5-R100	2,02 €	2,40 €
52_016a	30511	Dual seat lock pin for BMW /5 and up, with buffer to screw in, for replica dual seat	11,18 €	13,30 €
52_017	1236128	Dual seat rubber plug for BMW R45/R65, R80-R100RT, R80R and R100R 10mm	2,35 €	2,80 €
52_017	1230319	Dual seat rubber plug for BMW R50/5-R100, also for mono seat 5mm	1,93 €	2,30 €
52_020	9907639	Screw for seat grab handle for BMW /6-R100, M 5 x 10, raised countersunk head-crossed slot	1,01 €	1,20 €
52_021	32033	Dual seat bar for BMW R50/5, R60/5 and R75/5 until year of manufacture 09/1971, short wheel base chromed	57,73 €	68,70 €
52_021b	32966	Dual seat bar for BMW R50/5-R100/7 from year of manufacture 09/1971, long wheel base chromed	55,80 €	66,40 €
52_022	1238917	Double seat emblem for BMW R100RT	28,91 €	34,40 €
52_022	37764	Double seat emblem for BMW R75/5	19,58 €	23,30 €
52_022	2301936	Double seat emblem for BMW R80RT	21,76 €	25,90 €
52_022	2301295	Double seat emblem for BMW R100	25,88 €	30,80 €
52_024	1452427	Tool box cover for BMW R65-R80RT years 1985-1995, R80/100R years 1991-1995 R100 years 1987-1995, R80GS-R100PD years 1988-1990	7,73 €	9,20 €
52_024	40500	Tool box cover for BMW R90S and R60/7-R100	65,29 €	77,70 €
52_025	39963	Gasket tool box cover for BMW R45, R45T, R65 and R65T until year of manufacture 09/1980	3,45 €	4,10 €
52_025	32683	Gasket tool box cover for BMW R60/7-R100	10,00 €	11,90 €
52_025	32685	Gasket tool box cover for BMW R50/5-R90S for long wheel base and short wheel base (able to cut)	7,98 €	9,50 €
52_026	1456181	Tool box for BMW R65-R80RT years 1985-1995, R80/100R years 1991-1995 R100 years 1987-1995, R80GS-R100PD years 1988-1990	18,99 €	22,60 €
52_026	30396	Tool box for BMW R50/5, R60/5 and R75/5, long- and short wheel base	39,58 €	47,10 €
52_026	32640	Tool box for BMW R60/6-R100, long wheel base original BMW	31,51 €	37,50 €
52_026	1236175	Tool box for BMW R45 and R65 until year of manufacture 09/1980	30,25 €	36,00 €
52_026	1242167	Tool box for BMW R45 and R65 years of manufacture 09/1980-09/1984	51,85 €	61,70 €
52_034	2324830	Dual seat for BMW R100R, black original BMW	347,90 €	414,00 €
52_034	2307337	Dual seat cover for BMW R80GS and R100GS, yellow/black	54,29 €	64,60 €
52_034	01365	Dual seat for BMW R90S plain no pattern, without frame, Reproduction	190,34 €	226,50 €
52_034	71008	Dual seat cover for R90S plain no pattern	47,23 €	56,20 €
52_034	1453102	Dual seat for BMW R80ST, R65GS and R80G/S, black original BMW	354,79 €	422,20 €
52_034	30455	Dual seat cover for BMW R45 and R65, years 1978-1980	49,58 €	59,00 €
52_034	1452298	Dual seat for BMW R65RT SF, R80, R80RT from 1985 and R100RT from 1987 original BMW	389,41 €	463,40 €
52_034	1452530	Dual seat for BMW R80ST, R65GS and R80G/S, black plain no pattern, Reproduction	155,71 €	185,30 €
52_034	0071012	Dual seat cover for BMW R80ST, R65GS and R80G/S, black with pattern	50,00 €	59,50 €
52_034	0071013	Dual seat cover for BMW R45, R45T, R65 and R65T, years 1981-1984	47,23 €	56,20 €
52_034a	37834	Dual seat for BMW R80RT, R100S, CS, RS, RT, T, until year of manufacture 09/1984 and R90S (last version), cross pattern, without frame, Reproduction	206,05 €	245,20 €
52_034b	1237834	Dual seat for BMW R80RT, R100S/RT/T/CS/RT until year of manufacture 09/1984 original BMW	403,78 €	480,50 €



52_034e	71007	Dual seat cover for BMW R80RT, R100S/RT/T/CS/RS until year of manufacture 09/1984 also for BMW R90S "late version"	55,55 €	66,10 €
52_034g	1452293	Dual seat cover for BMW R65-R80RT from 1985 and R100RT/RS from 1987	59,41 €	70,70 €
52_034m	0071011	Dual seat cover for BMW R65GS and R80G/S, black plain no pattern	50,92 €	60,60 €
52_035	1232446	Mono seat frame for BMW R90S, R80RT und R100S-R100RS until year of manufacture 09/1984 grounded	220,67 €	262,60 €
52_036	1232904	Dual seat rubber plug for BMW R45/R65 and R90S-R100RT 16mm	2,44 €	2,90 €
52_037	1232459	Washer for seat handle/luggage carrier	1,34 €	1,60 €
52_040	98155	Screw for clutch 1-cylinder, also oilpump cover for BMW R60/6-R90S, M 6 x 16, hexagon	0,17 €	0,20 €
52_040	98153	Screw M 6 x 16, hexagon stainless steel	0,25 €	0,30 €
52_042	98326	Nut M 6, self-locking zincked	0,17 €	0,20 €
52_045	1232456	Dual seat bar for BMW R90S chrome	69,08 €	82,20 €
52_045b	1234635	Dual seat bar for BMW R80-R100RT until year of manufacture 09/1984 black	24,79 €	29,50 €
52_046	98163	Screw M 6 x 35, raised countersunk head, slotted stainless steel	0,59 €	0,70 €
52_047	1232458	Bushing for seat handle, luggage rack	2,61 €	3,10 €
52_048a	1239300	Luggage rack for BMW R90S, R80RT, R100S/RT/CS/RS chromed	97,82 €	116,40 €
52_048b	1240128	Luggage rack for BMW R90S, R80RT, R100S/RT/CS/RS black	75,55 €	89,90 €
52_050	9907639	Screw for seat grab handle for BMW /6-R100, M 5 x 10, raised countersunk head-crossed slot	1,01 €	1,20 €
52_053	1242360	Dual seat Duck tail for BMW R45, R45T, R65 and R65T from year of manufacture 09/1980	43,11 €	51,30 €
52_053	1237104	Dual seat Duck tail for BMW R45 and R65 until year of manufacture 09/1980	20,76 €	24,70 €
52_053	1233313	Gasket for dual seat frame for BMW R90S-100RT	18,15 €	21,60 €
52_054	33551	Double seat emblem for BMW R90S	12,77 €	15,20 €
52_054a	1236257	Emblem seat rear for BMW R45 and R65 until 09/1984, R65-R1150RT from 09/1984 Ø=60mm, Alu, stick-on label	11,18 €	13,30 €
52_055	2301695	Mono seat frame for BMW R100RS grounded	252,86 €	300,90 €
52_056	1237788	Mono seat for BMW R100RS, beige original BMW	229,08 €	272,60 €
52_056	452298	Dual seat for BMW R65, R80, R80RT from year of manufacture 09/1984 and for BMW R100RT/R100RS from year of manufacture 1987, Reproduction	167,90 €	199,80 €
52_056	452277	Dual seat Duck tail for BMW R65, R80 from 1985, R100 from 1987 including lower part, Reproduction	106,64 €	126,90 €
52_056	1240818	Dual seat for BMW R45 and R65 years of manufacture 1978-1980, black fits also years 1981-1984 models in combination with tail plastics 1978-1980 (articlenr: 1237104)	198,24 €	235,90 €
52_056	1242160	Dual seat for BMW R45, R45T, R65 and R65T years of manufacture 09/1980-09/194, black Reproduction	198,24 €	235,90 €
52_056	1237307	Mono seat cover for BMW R100RS until year of manufacture 09/1984, black	50,00 €	59,50 €
52_056bb	0037835	Mono seat for BMW R100RS, black, with rear part also for BMW R90S, R60/7-R100/7, CS, RT, Reproduction	323,87 €	385,40 €
52_060	1242174	Gasket for tool compartement for seat tail for BMW R45 and R65	1,51 €	1,80 €
52_060a	1240376	Tool compartement for seat tail for BMW R45 and R65 until year of manufacture 09/1980	7,73 €	9,20 €
52_060b	1242172	Tool compartement for seat tail for BMW R45 and R65, years of manufacture 09/1980-09/1984	34,12 €	40,60 €
52_061	1236128	Dual seat rubber plug for BMW R45/R65, R80-R100RT, R80R and R100R 10mm	2,35 €	2,80 €
52_061	1230319	Dual seat rubber plug for BMW R50/5-R100, also for mono seat 5mm	1,93 €	2,30 €
52_062	1234427	Gasket tool box cover for BMW R100RS, solo seat	17,23 €	20,50 €
52_066	0071009	Mono seat cover for BMW R60/6, R75/6 and R90/6, german police, black	47,23 €	56,20 €
52_066	0071010	Mono seat cover for BMW R60/7, R75/7, R80/7 and R100/7, german police, black	47,23 €	56,20 €
52_066	1152530	Solo seat for BMW R80G/S, ST and R65GS, black, WITH rear rack Reproduction	260,25 €	309,70 €
52_066a	30676	Solo seat for BMW R50/5-R90/6 until year of manufacture 09/1975, long wheel base original BMW	197,56 €	235,10 €
52_066b	5060755	Solo seat for BMW R50/5, R60/5 and R75/5, white cord, flat cover Reproduction	156,97 €	186,80 €
52_066c	30677	Solo seat for BMW R60/6-R90/6, LWB Reproduction	156,97 €	186,80 €
52_066d	37833	Solo seat for BMW R60/7-R100 and R45/R65 Reproduction	158,99 €	189,20 €
52_066gs	2307335	Solo seat for BMW R80GS/R100GS and R80R/R100R from year of manufacture 1988 black with rear rack, Reproduction	246,81 €	293,70 €
52_072	1236128	Dual seat rubber plug for BMW R45/R65, R80-R100RT, R80R and R100R 10mm	2,35 €	2,80 €
52_072	1230319	Dual seat rubber plug for BMW R50/5-R100, also for mono seat 5mm	1,93 €	2,30 €
52_073	42704	Solo seat hinge, front for solo seat	17,23 €	20,50 €
52_074	42706	Nut for single seat hinge, front see article 42704	7,14 €	8,50 €
52_076	00811	Screw for dual seat holder for BMW R50/5-R100	0,50 €	0,60 €
52_085	1234539	Radiobox R50/5-R100, Set	284,79 €	338,90 €
52_088	1238680	Cover fairing for BMW T- and RT-Models	1,68 €	2,00 €
52_090	31321	Trim strip Set dual seat for BMW R50/5, R60/5 and R75/5, short wheele base aluminium, incl. screws and nuts, ONLY FOR versions with 2 hand grips	43,19 €	51,40 €
52_090	31320	Trim strip Set dual seat for BMW R50/5-R90/6, long wheel base aluminum, incl. screws and nuts	50,00 €	59,50 €
52_092	1238679	Cover air-intake fairing for BMW T- and RT-Models	1,93 €	2,30 €



52_999 2307313 Dual seat for BMW R80GS and R100GS until year of manufacture 1987,
black original BMW

354,79 € 422,20 €

Group 61 Electric system

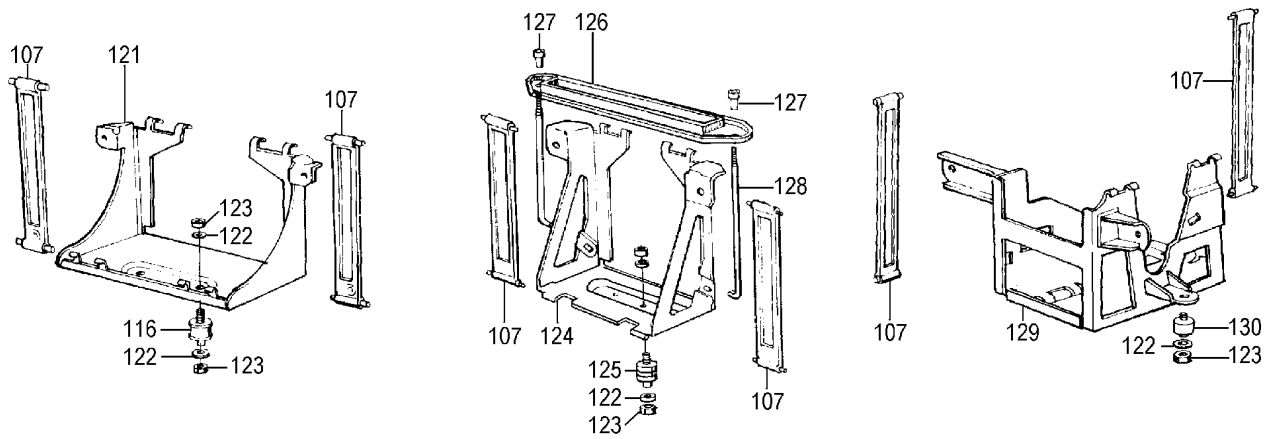
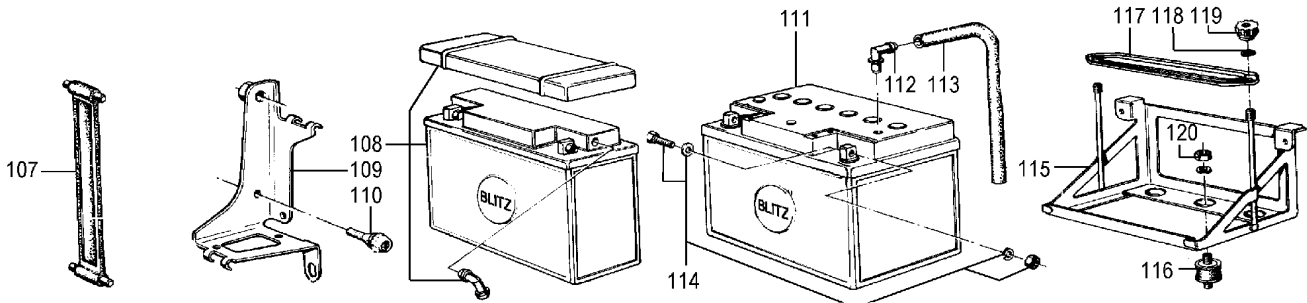
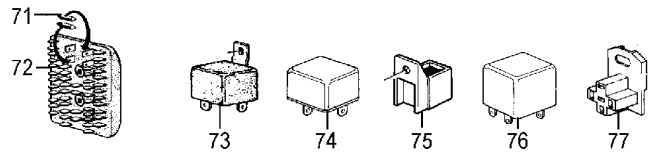

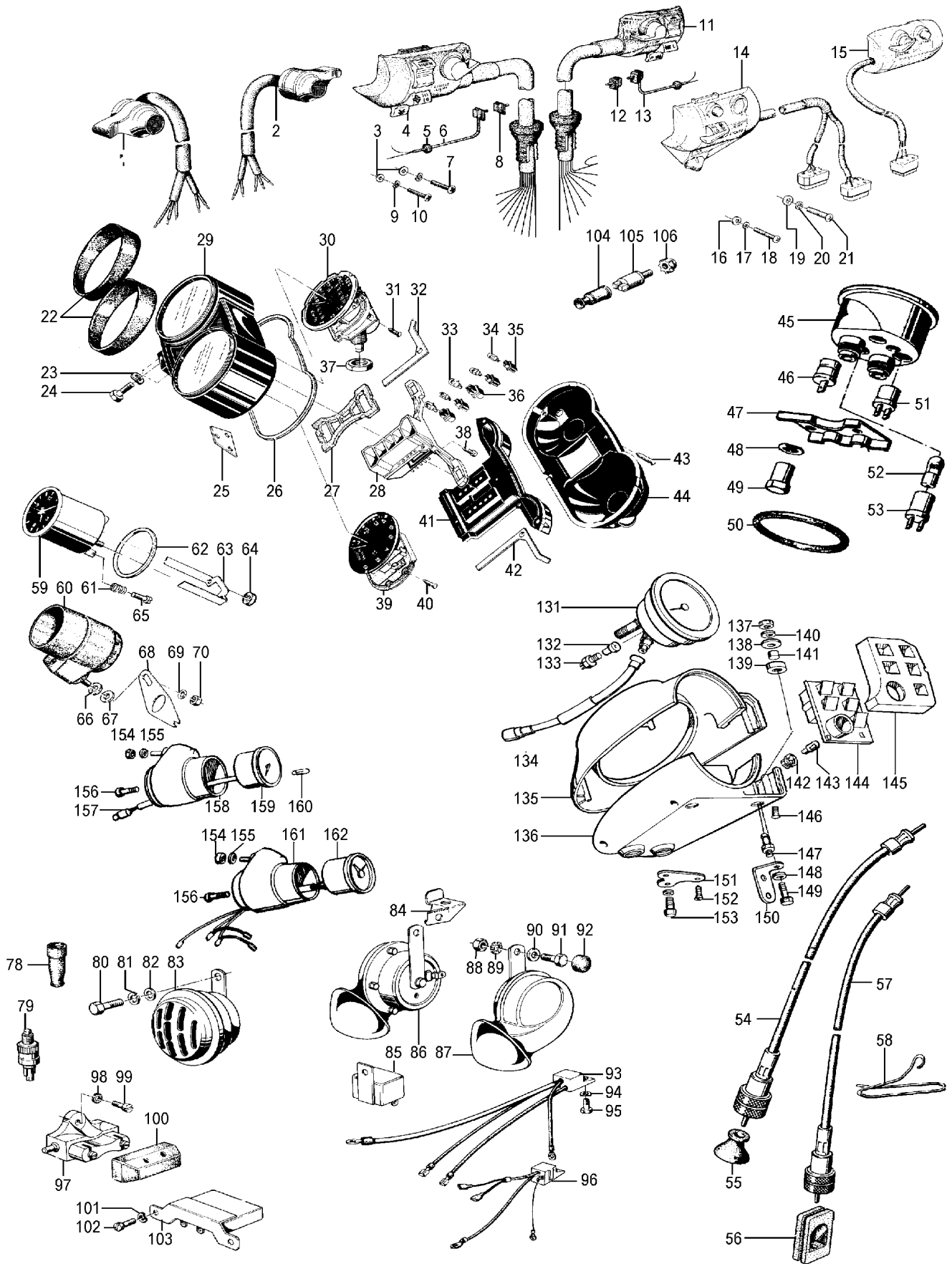

<u>Picture-No.</u>	<u>Article-No.</u>	<u>Description</u>	<u>Net</u>	<u>Gross</u>
61_0	98157	Screw M 6 x 20, hexagon	0,17 €	0,20 €
61_000	1243186	Cable set, tail light for BMW R60/6-R100 and R100RT	4,12 €	4,90 €
61_000	2316081	Heating grip retrofit kit R80R, R100R	149,83 €	178,30 €
61_000	270060	Isolating tube, 6mm price per meter	0,84 €	1,00 €
61_000	270080	Isolating tube, 8mm price per meter	1,09 €	1,30 €



61_000	2300473	Installation kit for female plug for BMW R65-R100RT from year of manufacture 1985 complete, to upgrade	35,97 €	42,80 €
61_000	98682	Isolating tube (shrink-to-fit), 12mm price per meter	1,26 €	1,50 €
61_000	2315221	Heating grip LH R850R-R1100RT, RS	45,46 €	54,10 €
61_000	1358107	Wiring harness, neutralswitch for BMW R60/6-R100 until year of manufacture 09/1977	15,38 €	18,30 €
61_000	98681	Isolating tube (shrink-to-fit), 10mm price per meter	1,26 €	1,50 €
61_000	98683	Isolating tube (shrink-to-fit) 3,2mm price per meter	4,79 €	5,70 €
61_000	98679	Isolating tube (shrink-to-fit), 4mm price per meter	0,50 €	0,60 €
61_000	1361706	Heating grip push-on contact R80GS-R1100RT	0,84 €	1,00 €
61_000	1459982	Heating grip switch R850R-R1100RT	18,15 €	21,60 €
61_000	99503	Bulb 12 Volt, 18 Watt, festoon-bulb	1,93 €	2,30 €
61_000	2315222	Heating grip RH R850-R1100RT, RS	50,00 €	59,50 €
61_000	98680	Isolating tube (shrink-to-fit), 5mm price per meter	0,67 €	0,80 €
61_000	9062462	Indicator light button repair kit for BMW motorcycles from year of manufacture 09/1980	3,95 €	4,70 €
61_000	5009	Indicator relay 12V, electronic, for bar-end indic. - Ochsenaugen	18,24 €	21,70 €
61_000	1243216	Battery cable plus for BMW R60/7-R100 from year of manufacture 09/1978	15,04 €	17,90 €
61_000	1452341	Battery carrier for BMW R65-80RT from year of manufacture 1985 and BMW R100 from year of manufacture 1987	18,99 €	22,60 €
61_000	1244038	Fuse box for BMW R45/R65 from year of manufacture 09/1980 and for BMW R100RS, R100RT, years 09/1986-01/1991	36,30 €	43,20 €
61_000	1353489	Cable set, indicator controll for BMW R50/5, R60/5 and R75/5	8,74 €	10,40 €
61_000	1238004	Holder Voltmeter for BMW R45 and R65, right side	3,03 €	3,60 €
61_000	1238003	Holder Voltmeter for BMW R45, R45/N and R65, left side	3,95 €	4,70 €
61_000	1243523	Wiring harness, neutralswitch for BMW R45-R100RT, all models years of manufacture 09/1977-09/1994	18,99 €	22,60 €
61_000	1243583	Flashing indicator for BMW R45-R65LS, left side	12,10 €	14,40 €
61_000	1243584	Flashing indicator for BMW R45-R65LS, right side	12,10 €	14,40 €
61_000a	1354674	Wiring harness for BMW R50/5, R60/5 and R75/5	91,51 €	108,90 €
61_000b	1358178	Wiring harness for BMW R60/6-R90S from year of manufacture 09/1974	222,27 €	264,50 €
61_000c	1357457	Wiring Harness for BMW R60/6-R90S, years of manufacture 09/1973-09/1974	222,35 €	264,60 €
61_000d	1243194	Wiring harness for BMW R60/7-R100/7 and R100S until year of manufacture 09/1977	222,35 €	264,60 €
61_000e	1243522	Wiring harness for BMW R80, R100RT and R100RS, years of manufacture 09/1977-09/1980	224,20 €	266,80 €
61_000f	1243521	Wiring harness for BMW R60/7-R100T and R100S, years of manufacture 09/1977-09/1980	230,92 €	274,80 €
61_000g	1243564	Wiring harness for BMW R45 and R65 until year of manufacture 08/1980, frame	97,73 €	116,30 €
61_000g	1244091	Wiring harness for BMW R45, R65, R65LS and R80ST from year of manufacture 09/1980, frame	121,09 €	144,10 €
61_000h	1244830	Wiring harness for BMW R80GS Basic	274,29 €	326,40 €
61_000h	1244425	Wiring harness for BMW R65RT SF and R80RT, years of manufacture 1985-1991 and for BMW R100RT/R100RS from year of manufacture 1987	230,92 €	274,80 €
61_000i	1244098	Wiring harness for BMW R80RT, R100RS and R100RT, years of manufacture 09/1980-09/1984	231,68 €	275,70 €
61_000j	1244093	Wiring harness for BMW R80/7, R80, R100T and R100CS, years of manufacture 09/1980-09/1984	230,92 €	274,80 €
61_000k	1244421	Wiring harness for BMW R65GS and R80G/S, years of manufacture 09/1980-09/1987	217,82 €	259,20 €
61_001a	51220	Lightswitch for BMW R50/5-R90S with Cable until year of manufacture 09/1974 CURRENTLY NOT AVAILABLE, DELIVERY DATE UNKNOWN	81,85 €	97,40 €
61_004e	1243598	Lightswitch for BMW R60/7-R100, left side, years of manufacture 09/1974-09/1978 steady light, cable length 380mm	96,39 €	114,70 €
61_006	43496	Switch clutch / brake for BMW R60/6-R100 from year of manufacture 10/1974 and for BMW R65GS-R100GS from year of manufacture 09/1980	33,95 €	40,40 €
61_011	2305231	Switch-combination left for BMW with steady light	166,55 €	198,20 €
61_011d	2305232	Switch-combination right for BMW R80/R100R, R80/R100GS from year of manufacture 09/1990 with light switch	166,55 €	198,20 €
61_013	53985	Grommet lightswitch / indicator switch/headlight for BMW R50/5, R60/5 and R75/5	1,01 €	1,20 €
61_014a	1243864	Switch-combination left for BMW cable: 230mm, including headlight switch	104,37 €	124,20 €
61_014b	1243865	Switch-combination left for BMW cable: 380mm, including headlight switch	104,37 €	124,20 €
61_014c	1243866	Switch-combination left for high handlebar for BMW cable: 520mm, including headlight switch	104,29 €	124,10 €
61_014d	1243814	Switch-combination, 78->, 230mm, (perm. headl.) cable : 230mm, with permanent headlight	71,76 €	85,40 €
61_014e	1243815	Switch-combination, 78->, 380mm, (perm.headl.) cable : 380mm, with permanent headlight	104,37 €	124,20 €
61_014f	1243816	Switch-combination left for high handlebar for BMW cable: 520mm, with steady light	84,45 €	100,50 €
61_014g	44420	Switch-combination left for BMW	104,37 €	124,20 €
61_014h	1244410	Switch-combination left for BMW including headlight switch	158,66 €	188,80 €
61_014i	1244418	Switch-combination, R 65RT-100RT, 85-> with permanent headlight	137,82 €	164,00 €



61_015b	1243812	Switch-combination right for BMW R60/7-R100RS from year of manufacture 09/1978 for high bars/RS-fairing, 380mm	104,54 €	124,40 €
61_015c	1243813	Switch-combination right for BMW R60/7-R100RS from year of manufacture 09/1978 for high bars/RS-fairing, 520mm	104,62 €	124,50 €
61_015d	1244417	Switch-combination right for BMW R45/R65-R80RT from year of manufacture 09/1984 GS-/ST-/PD from year of manufacture 09/1979 and R100 from year of manufacture 09/1986	96,47 €	114,80 €
61_022	1356676	Rubber ring for instruments for BMW R60/6-R100RT	11,18 €	13,30 €
61_026	1356671	Rubber seal for instrument housing from BMW R60/6 and up	1,76 €	2,10 €
61_028	1356665	Light support (inner PCB for clocks) R60/6-R100 ->09/77	167,23 €	199,00 €
61_028a	1243439	Light support R75/7-R100 09/77-09/80	167,23 €	199,00 €
61_028b	1244129	Light support R65-R100 09/80->	167,23 €	199,00 €
61_029	1356664	Instrument housing for BMW R60/6-R100RS, until year of manufacture 09/1977	212,10 €	252,40 €
61_029c	43431	Instrument combination for BMW R60/7, years of manufacture 09/1977-09/1980, W:0.819 revolution counter	357,48 €	425,40 €
61_029g	1243436	Instrument housing for BMW R60/6-R100, years of manufacture 09/1977-09/1980	173,03 €	205,90 €
61_029h	1244779	Instrument housing for BMW R80/7-R100 from year of manufacture 09/1980	173,03 €	205,90 €
61_029i	1236896	Handlebar crash plate for BMW R45/R65 and R80ST, upper part	263,95 €	314,10 €
61_030e	1358115	Speedo R60/6, R60/7 W=0.819, 32:9	180,76 €	215,10 €
61_030h	1244771	Speedo R80R-R100R, W:0,715	272,61 €	324,40 €
61_030i	1358126	Speedo MPH R90S, R100S, R100RS -> 09/77, W=1,078	276,97 €	329,60 €
61_033a	1350062	Bulb 12 Volt, 2 Watt, glass-socket	1,18 €	1,40 €
61_033b	9978372	Bulb 12 Volt, 3 Watt, glass-socket	1,18 €	1,40 €
61_034	9978375	Bulb 12Volt, 1,2 Watt, glass-socket	0,92 €	1,10 €
61_035	1244643	Bulb holder for BMW from R60/6 for 1,2 Watt bulb	5,46 €	6,50 €
61_036	1356714	Bulb holder for BMW from R60/6 for 3 Watt glas-socket bulb	2,18 €	2,60 €
61_037b	43112	Securing nut for revolution counter REMNANTS	1,01 €	1,20 €
61_039e	1244784	Revolution counter for BMW R80R-R100R, PD, Mystic	244,03 €	290,40 €
61_040	1244769	Screw for instrument-housing, 3 x 16	1,51 €	1,80 €
61_044	1356674	Cover instrument housing for BMW R60/6-R100, lower	34,71 €	41,30 €
61_044b	1236297	Cover instrument housing, for BMW R45-R65LS, R80ST, years of manufacture 1978-09/1984, lower	22,52 €	26,80 €
61_045	52621	Speedo with revolution counter, 20-200 km/h, gear ratio: 0,800 for BMW R50/5	245,80 €	292,50 €
61_045	53676	Speedo with revolution counter, 20-200 km/h, gear ratio: 0,715 for BMW R75/5	245,80 €	292,50 €
61_045	50566	Speedo with revolution counter, 20-200 km/h, gear ratio: 0,760 for BMW R60/5	245,80 €	292,50 €
61_045	5056601	Speedo with revolution counter, 10-120 mph, gear ratio: 1,215 for BMW R60/5	245,80 €	292,50 €
61_045	5367601	Speedo with revolution counter, 10-120 mph, gear ratio: 1,150 for BMW R75/5	245,80 €	292,50 €
61_045a	1243323	Speedo R45, R45T, W: 0,895	273,03 €	324,90 €
61_045b	43322	Speedo R45N W: 0.978 up until 09/84	264,03 €	314,20 €
61_045cc	5156601	Speedo for BMW R50/5 with rpm-counter, 10-120 MPH (Miles) Ratio: 1.280	245,80 €	292,50 €
61_045g	80091	Chrome rim for speedo for BMW R50/5-R75/5 with rubber gasket	17,23 €	20,50 €
61_049	50574	Nut for speedometer bracket for BMW R50/5, R60/5 and R75/5	0,76 €	0,90 €
61_050	56593	Gasket ring from BMW R50/5 and up (O-Ring) between speedo and shell	2,02 €	2,40 €
61_051	8680131	Bulb holder double-pole for BMW R50/5-R75/5, socket BA9S (charge indicator)	4,29 €	5,10 €
61_052	20051	Bulb 6 Volt, 2 Watt, socket BA9S e.g. control-light, sidelight	1,01 €	1,20 €
61_053	8081725	Bulb holder double-pole for BMW R50/5-R75/5, socket BA7S	4,96 €	5,90 €
61_054	57731	Speedo cable for BMW R45/R65, R80G/S and R60/6-R100R	12,94 €	15,40 €
61_054	1016	Speedo cable for BMW R26, R27, R50-R69S and R50/5-R75/5 small fixture diameter	11,60 €	13,80 €
61_054	2315115	Speedo cable for BMW R80GS/PD and R100GS/PD from year of manufacture 1987	72,35 €	86,10 €
61_055	80160	Grommet speedocable / gearbox for BMW R24-R69S and R50/5-R100	1,51 €	1,80 €
61_056	51554	Grommet revolution counter cable for BMW R50/5-R100RS until year of manufacture 09/1977	7,39 €	8,80 €
61_057	1357732	Revolution counter cable for BMW R50/5-R90/6	25,88 €	30,80 €
61_064	1459257	Battery carrier bridge twist-nut for BMW R65-R100RT from year of manufacture 09/1984 and additional instruments R50/5-R100	1,60 €	1,90 €
61_068	1240651	Additional instrument mounting flap, black	5,97 €	7,10 €
61_072a	1357593	Contact plate lamp for BMW R60/6-R90S until year of manufacture 09/1974	61,68 €	73,40 €
61_074	1244411	Relay for light for BMW R65-R80RT from year of manufacture 09/1984 and for BMW R100RS, R100RT from year of manufacture 1987	48,15 €	57,30 €
61_074a	58193	Relay headlight switch for BMW R60/6-R100 from year of manufacture 09/1974 WITHOUT Diode	13,11 €	15,60 €
61_074b	43049	Relay headlight switch for BMW R60/7-R100 from year of manufacture 1979 WITH Diode	52,18 €	62,10 €
61_074c	243086	Light relay for BMW R60/6-R100	10,92 €	13,00 €
61_076	2306014	Indicator relay for BMW R80GS-R100R Mystic from year of manufacture 1991	82,18 €	97,80 €
61_076	1244392	Indicator relay for BMW R45-R1100R from year of manufacture 09/1980 with hazard-warning signal flasher	31,51 €	37,50 €
61_076a	1352941	Indicator relay 12V for BMW R50/5-R75/5	12,10 €	14,40 €



61_076b	1358194	Indicator relay 12V, electronic for BMW R60/6-R100, manufactured from 09/1974-09/1980	92,52 €	110,10 €
61_078	44071	Grommet brake light switch, front for BMW models from year of manufacture 09/1980	2,77 €	3,30 €
61_083	1243486	Horn 12 Volt, Ø 120mm, from BMW 50/5 and up chromed	14,62 €	17,40 €
61_083b	2072	Horn 12 Volt, Ø 100mm chromed	13,19 €	15,70 €
61_085	1373585	Relay horn for BMW R45/R65 and R60/7-R100	34,12 €	40,60 €
61_097	6005	Brake light switch, years of manufacture 09/1954-09/1980, rear	5,97 €	7,10 €
61_097	8070184	Mounting plate for brake light switch article nr. 6005 for BMW R24-R25/3 and R51/2	12,94 €	15,40 €
61_097a	1459747	Brake light switch BMW R80GS-R100R from year of manufacture 1988, rear also for BMW R850GS-R1200C	31,60 €	37,60 €
61_098	98461	Tooth lock washer 4,3mm	0,08 €	0,10 €
61_100	8005	Cover cap for Brake light switch, rear	1,60 €	1,90 €
61_103	1352425	Contact plug for horn / brakelight switch for BMW R50/5	4,29 €	5,10 €
61_104	51646	Grommet brake light switch, front for BMW R50/5-R90S	3,45 €	4,10 €
61_105a34_022	1351662	Brake light switch, years of manufacture 09/1969-09/1974, front, with grommet and starter switch for BMW R60/6 until year of manufacture 09/1974	61,43 €	73,10 €
61_105b	1244070	Brake light switch, year of manufacture 09/1976-09/1984, front NOT FOR BMW R45 and R65 from year of manufacture 09/1980-09/1984	8,66 €	10,30 €
61_105c	1459569	Brake light switch for BMW-Models from year of manufacture 09/1984, front and for BMW R65-R80RT from year of manufacture 09/1984, rear	23,61 €	28,10 €
61_107A	1230392	Battery strap for BMW R50/5-R75/5 until year of manufacture 08/1973	6,55 €	7,80 €
61_107B	1243562	Battery strap for BMW R45/R65-R80RT, R80/R100R and R65GS-R100GS	9,92 €	11,80 €
61_108	1459014	Battery 12V, for BMW R50/5-R75/5, short wheel base maintenance-free – No shipment outside the European Union possible!	72,69 €	86,50 €
61_108	0050512	Battery 12V, for BMW R27-conversation, R50-R69S maintenance-free – No shipment outside the European Union possible!	39,92 €	47,50 €
61_108	1559014	Battery 12V, for BMW R45, R65 and R80 maintenance-free – No shipment outside the European Union possible!	72,69 €	86,50 €
61_108	1659014	Battery 12V, for BMW R80G/S and R80ST maintenance-free – No shipment outside the European Union possible!	72,69 €	86,50 €
61_108b	59014	Battery 12V, for BMW R50/5-R75/5, short wheel base (for own filling with acid) - (white)	60,92 €	72,50 €
61_108b	1059014	Battery 12V, for BMW R45 and R65 (for own filling with acid) - (white)	60,92 €	72,50 €
61_108b	1159014	Battery 12V, for BMW R80G/S and R80ST (for own filling with acid) - (white)	60,92 €	72,50 €
61_108d	3024	Battery 12V, for 12V-conversation, 12N5.5-3B (for own filling with acid) – (white), REMNANTS	29,33 €	34,90 €
61_109a	1230772	Battery carrier for BMW R50/5, R60/5 and R75/5, right side, short wing base	50,34 €	59,90 €
61_109b	1230771	Battery carrier for BMW R50/5, R60/5 and R75/5, left side, Short wing base	50,34 €	59,90 €
61_110	1231084	Rubber buffer for battery bracket for BMW from R50/5 and higher, short wing base and headlight from R60/6 and higher	2,44 €	2,90 €
61_111b	94025	Battery 12V, for R50/5-R100, long wheel base (for own filling with acid) - (white)	64,71 €	77,00 €
61_115	1233076	Battery carrier for BMW R60/6-R100, Long wheel base	111,01 €	132,10 €
61_116a	33028	Silent block battery holder for BMW R50/5-R100 until year of manufacture 09/1977 and R65GS-R100GS, 1980-1996 and R65-R100R, 1985-1995	6,89 €	8,20 €
61_116b	43530	Silent block battery holder for BMW models from year of manufacture 09/1977 and cockpit holder for BMW R80R and R100R	11,18 €	13,30 €
61_117	1233073	Battery carrier bridge for BMW R60/6-R100 until year of manufacture 08/1983	28,15 €	33,50 €
61_119	1459257	Battery carrier bridge twist-nut for BMW R65-R100RT from year of manufacture 09/1984 and additional instruments R50/5-R100	1,60 €	1,90 €
61_121	1243302	Battery carrier for BMW R45, R65, R65GS, R80G/S, ST	35,71 €	42,50 €
61_126	1452240	Battery carrier bridge for BMW R65-R80RT from year of manufacture 1985 and BMW R100 from year of manufacture 1987	18,99 €	22,60 €
61_127	1459257	Battery carrier bridge twist-nut for BMW R65-R100RT from year of manufacture 09/1984 and additional instruments R50/5-R100	1,60 €	1,90 €
61_128	1452342	Battery carrier spoke for BMW R65-R80RT from year of manufacture 1985 and R100 from year of manufacture 1987	2,18 €	2,60 €
61_135	1244042	Front housing headlamp, R65GS-R100GS >09/89	62,02 €	73,80 €
61_150a	1244133	Instrument holder for BMW R65 and R80G/S, upper, left	8,57 €	10,20 €
61_150b	1244134	Instrument holder for BMW R65 and R80G/S, upper, right	8,57 €	10,20 €
61_151	1244055	Instrument holder for BMW R65 and R80G/S, lower	4,37 €	5,20 €
61_157	1357591	Wiring harness, auxiliary instruments for BMW R90S, R100S and R100CS with bulb-holder	43,36 €	51,60 €
61_157b	1357703	Wiring harness, voltmeter for BMW R60/6-R100/7 and RT with bulb-holder	29,41 €	35,00 €
61_159b	44668	Voltmeter 09/77->	109,50 €	130,30 €
61_999	1459305	Hazard warning light switch for BMW R80R and R100R	29,41 €	35,00 €
61_999	43393	Fuse box housing for BMW R45 and R65 until year of manufacture 09/1980	4,62 €	5,50 €
61_999	1391630	Female plug for BMW R80-R100R until year of manufacture 1995	18,91 €	22,50 €
61_999	1459319	Ignition lock plastic washer for BMW R65-R100R	5,55 €	6,60 €
61_999	1244464	Grommet wiring harness / engine for BMW R60/7-R100 from year of manufacture 09/1978, 2-holes	2,18 €	2,60 €



Group 63 Light

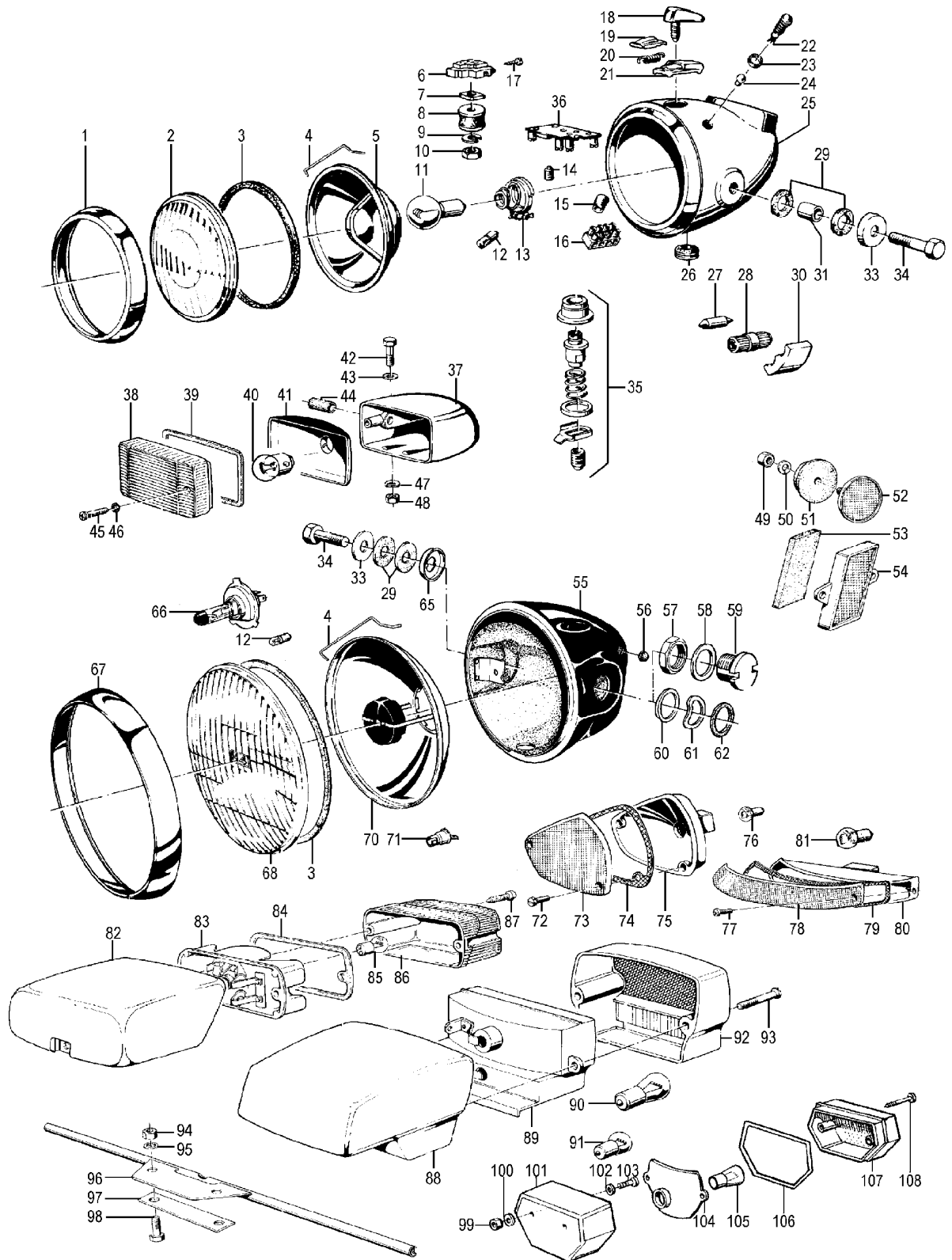

Picture-No.	Article-No.	Description	Net	Gross
63_0	270060	Isolating tube, 6mm price per meter	0,84 €	1,00 €
63_00	1052	Headlight guard for BMW R24-R75/5 chromed	17,23 €	20,50 €
63_000	2315655	Indicator light holder for BMW R80GS-R100PD, rear	8,24 €	9,80 €
63_000	9907988	Headlight screw for BMW R65GS-R100GS/PD	0,50 €	0,60 €
63_000	1244147	Headlight gasket ring forBMW R65GS-R100GS	6,89 €	8,20 €
63_000	1244024	Headlight carrier R65GS-R100GS	10,00 €	11,90 €
63_000	1244023	Headlight ring for BMW R65GS-R100GS	17,06 €	20,30 €
63_000	98682	Isolating tube (shrink-to-fit), 12mm price per meter	1,26 €	1,50 €
63_000	54159	Bar end indicator with 6V bulb and cable aluminium polished	25,29 €	30,10 €
63_000	98681	Isolating tube (shrink-to-fit), 10mm price per meter	1,26 €	1,50 €



63_000	89001	Bulb 12 Volt, 102/2 Watt, socket BA7S e.g. speedo	1,01 €	1,20 €
63_000	98683	Isolating tube (shrink-to-fit) 3,2mm price per meter	4,79 €	5,70 €
63_000	1453521	Lock cover ring for BMW R80R, R100R/Mystic and R80GS, R100GS/PD	0,59 €	0,70 €
63_000	98679	Isolating tube (shrink-to-fit), 4mm price per meter	0,50 €	0,60 €
63_000	78304	Bulb 12 Volt, 5 Watt, festoon-bulb	1,93 €	2,30 €
63_000	78305	Bulb 12 Volt, 10 Watt, festoon-bulb	1,93 €	2,30 €
63_000	99505	Bulb 12 Volt, 5 Watt e.g. license plate illumination	1,43 €	1,70 €
63_000	9907910	Sheet metal screw, 3,9x9,5mm, for headlight for BMW R65GS-R100GS	1,01 €	1,20 €
63_000	00111	Chrome rim 130mm, Hella-headlight p.e. XT 500, NSU	22,10 €	26,30 €
63_000	2011	Bar end indicator lens, "E" approved	7,06 €	8,40 €
63_000	98680	Isolating tube (shrink-to-fit), 5mm price per meter	0,67 €	0,80 €
63_000	99501	Bulb 12 Volt, 2 Watt, socket BA9S	1,01 €	1,20 €
63_000	1244764	Headlight bracket R80R, R100R black	73,70 €	87,70 €
63_001	1351651	Chrome rim for BMW R50/5-R75/5, Headlight	22,10 €	26,30 €
63_001b	20014	Direction indicator switch universal with clamp chromed	11,09 €	13,20 €
63_002	12013	Headlight lens "H4" for BMW R24-R75/5 and R45/R65 until year of manufacture 09/1984, front, BOSCH	23,36 €	27,80 €
63_002	1351650	Headlight lens for BMW R50/5, R60/5 und R75/5, Bilux, BOSCH	43,11 €	51,30 €
63_002	5603004	Headlight lens for BMW R24-R69S, BOSCH "old" style lettering	25,13 €	29,90 €
63_002a	11013	Headlight lens "H4" for BMW R24-R75/5 and R45/R65 until year of manufacture 09/1984, ZEV	10,34 €	12,30 €
63_002b	8007	Headlight lens for BMW R24-R69S	25,13 €	29,90 €
63_002c	43542	Headlight lens "H4" for BMW R50/5, R60/5, R75/5, R45, R65 and R80ST for LEFT-HAND-TRAFFIC	87,98 €	104,70 €
63_002C	1352557	Headlight lens for BMW R50/5, R60/5 and R75/5 fits also for R24-R69S for LEFT-HAND-TRAFFIC	43,19 €	51,40 €
63_003	1007	Headlight lens gasket for BMW R24-R75/5, front	1,93 €	2,30 €
63_003a	1356403	Headlight lens gasket for BMW R60/6-R100	15,71 €	18,70 €
63_004	48181	Headlight clip	0,59 €	0,70 €
63_005	600111	H4-Headlight insert for BMW-models, 130mm, WITHOUT bulb	29,41 €	35,00 €
63_005a	78001	Reflector for halogen headlight for BMW R50/5, R60/5, R75/5 and R45/R65 WITH bulb-holder and spring	26,64 €	31,70 €
63_005b	6011	H4-Headlight insert for BMW R24-R69S, R50/5-R75/5, R45 and R65, "plastic-reflector", WITHOUT bulb with bulb-holder and spring	29,41 €	35,00 €
63_005bb	6316011	H4-Headlight insert for BMW R24-R69S, R50/5-R75/5, R45 and R65, "metal-reflector", WITHOUT bulb with bulb-holder and spring	29,41 €	35,00 €
63_006	1363083	Plug base Indicator relay for BMW R45/R65 and R60/6-R100 REMNANTS	1,93 €	2,30 €
63_006	08018	H4-plug base, also as indicator plug base for BMW R50-R100	5,55 €	6,60 €
63_008	56139	Silent block indicator relais for BMW R50/5, R60/5 and R75/5 in headlight	1,76 €	2,10 €
63_010	1233070	Spoke wheel for BMW R50/5-R60/6, front for drum brake, measurement rim: 1.85 x 19	535,63 €	637,40 €
63_011	8001006	Bulb 12 Volt, LED, socket BA20D, white for Headlight, (replacement for 35/35 Watt) WITHOUT compliance	15,63 €	18,60 €
63_011a	64185	Bulb 12 Volt, 35/35 Watt, socket BA20D	6,55 €	7,80 €
63_012	99504	Bulb 12 Volt, 4 Watt e.g. position light	1,01 €	1,20 €
63_012a	78242	Bulb 6 Volt, 3 Watt e.g. sidelight	1,01 €	1,20 €
63_012b	2301607	Indicator light holder for BMW R50/5-R100/7, front, black	37,82 €	45,00 €
63_012c	2005121	Bulb 12 Volt, LED, socket BA9S, white e.g. side-light	2,44 €	2,90 €
63_016a	50508	Wiring connector 12pc. 6.0	1,93 €	2,30 €
63_016a	50507	Wiring connector 12pc. 2.5	1,76 €	2,10 €
63_018	48119	Ignition key for BMW R25/3-R75/5 metal version	5,97 €	7,10 €
63_018	8014	Ignition key for BMW R25/3-R75/5 black	6,22 €	7,40 €
63_019	9013	Ignition cover slide for BMW R25/3-R27, R51/3, R67/3, R68 and R50-R69S	3,87 €	4,60 €
63_020	48191	Spring for ignition cover slide for BMW R25/3-R27, R51/3, R67/3, R68 and R50-R69S	1,18 €	1,40 €
63_021	48189	Cover for ignition switch, single	13,03 €	15,50 €
63_021a	6013	Cover for ignition switch set complete with spring and sliding cover	17,82 €	21,20 €
63_022a	56987	Indicator control lens blinker for BMW R50/5, R60/5 and R75/5, green	10,00 €	11,90 €
63_022b	1356986	Indicator control lens blinker for BMW R50/5, R60/5 and R75/5, yellow	10,00 €	11,90 €
63_022d	48129	Indicator control lens neutral for BMW-models until year of manufacture 1954, green true to original	10,00 €	11,90 €
63_025	56278	Headlight for BMW R50/5, R60/5 and R75/5, complete WITHOUT speedometer	649,16 €	772,50 €
63_026	43476	Grommet wiring harness / shell for BMW R50/5 and up also for cable management R51/2-R68	1,09 €	1,30 €
63_026	19007	Grommet speedocable / headlight for BMW R24-R69S and for revolution counter cable / headlight for BMW R50/5-R75/5	1,76 €	2,10 €
63_026	53985	Grommet lightswitch / indicator switch/headlight for BMW R50/5, R60/5 and R75/5	1,01 €	1,20 €
63_027	98611	Fuse 8A, white or black, Bakelite®	0,34 €	0,40 €
63_027	0098611	Fuse 8A, black, 16mm, Bakelite®	0,25 €	0,30 €



63_028	98620	Fuse holder for Bakelite fuses "flying fuse"	2,61 €	3,10 €
63_029	8008	Headlight rubber, round (washer) (you need 4 pcs for one Headlight!)	1,34 €	1,60 €
63_031	50138	Spacer rubber for headlight ear	1,76 €	2,10 €
63_033	50134	Headlight washer stainless steel, polished	3,45 €	4,10 €
63_034	13661	Headlight bolt stainless steel, polished	2,61 €	3,10 €
63_035	1013	Ignition lock assembly for BMW R25-R75/5	38,91 €	46,30 €
63_036	48173	Contact plate for BMW R50/5, R60/5 and R75/5	104,54 €	124,40 €
63_037a	50495	Indicator light housing from BMW R50/5-R100 fits for reflector and accessory shoe aluminum polished	25,13 €	29,90 €
63_037b	1350494	Indicator light for BMW R50/5, R60/5 and R75/5 aluminum polished	34,54 €	41,10 €
63_037bb	1350495	Indicator light for BMW R50/5, R60/5 and R75/5 aluminium polished, with "E" -mark	36,39 €	43,30 €
63_037c	1243442	Indicator light for BMW R60/6-R100R plastic	20,59 €	24,50 €
63_037ca	1243447	Indicator light for BMW R60/6-R100R plastic, with "E"-mark	21,60 €	25,70 €
63_037cb	1243444	Indicator light housing for BMW R60/6-R100 fits for reflector and accessory shoe black, plastic	11,26 €	13,40 €
63_037d	1350642	Cable set, indicators for BMW R50/5-R75/5, front	12,94 €	15,40 €
63_037e	1357588	Wiring harness, indicator for BMW R60/6-R90S, front	8,24 €	9,80 €
63_037f	1243206	Cable set, indicators for BMW and R100S/RS/T/RT, front	21,51 €	25,60 €
63_038	1243445	Indicator light lens for BMW R50/5-R100 with "E"-mark	5,13 €	6,10 €
63_038	1358183	Indicator light lens for BMW from R50/5 original BMW	10,76 €	12,80 €
63_038a	2243445	Indicator light lens for BMW R50/5-R100	3,61 €	4,30 €
63_039	1351407	Gasket for indicator light lens for BMW R50/5-R100 original BMW	1,18 €	1,40 €
63_039	80115	Gasket ring for BMW R24-R69S (O-Ring between speedo and shell) and gasket indicator glas for BMW R50/5 and up	1,18 €	1,40 €
63_040	99502	Bulb 12 Volt, 21 Watt, socket BA15S ball-bulb	1,43 €	1,70 €
63_041	1243443	Indicator light reflector for BMW R50/5-R100	6,30 €	7,50 €
63_044	1351257	Grommet for indicator light for BMW R50/5-R90S	0,59 €	0,70 €
63_045	9907643	Indicator light lens screw for BMW R50/5-R100	1,60 €	1,90 €
63_046	9963002	Gasket ring for indicator light lens screw	0,50 €	0,60 €
63_052	1354792	Side reflector red, bag-set for BMW R50/5-R90S and R45-R65LS US-Version!	9,08 €	10,80 €
63_055	43483	Headlight for BMW R60/6-R100, complete WITHOUT speedometer	291,26 €	346,60 €
63_057	43279	Ignition lock mounting nut for BMW R60/6-R100, outer	4,96 €	5,90 €
63_057	43278	Ignition lock mounting nut for BMW R60/6-R100, inner	4,96 €	5,90 €
63_059	43273	Ignition lock for BMW R60/6-R100RT until year of manufacture 09/1974 3 positions	86,30 €	102,70 €
63_061	1357502	Headlight rubber for BMW R60/6-R100, left side for ignition look	2,86 €	3,40 €
63_062	038126	Washer drive shaft flange for BMW R26 and R27, 1,0mm also as washer for ignition lock for BMW /6 and up	1,93 €	2,30 €
63_066	8001008	Bulb 12 Volt, LED, socket PT43, white for Headlight, (replacement for 35/35 Watt) WITHOUT compliance	15,63 €	18,60 €
63_066a	1354619	Bulb 12 Volt, 60/55 Watt, Halogen-H4, socket P43T	5,21 €	6,20 €
63_066b	54620	Bulb 12 Volt, 100/80 Watt, Halogen-H4, socket P43T	8,49 €	10,10 €
63_066c	54622	Bulb 12 Volt, 55/100 Watt, Halogen-H4, socket P43T	8,49 €	10,10 €
63_066d	54621	Bulb 12 Volt, 100/80 Watt, Halogen-H4, socket P45T	11,09 €	13,20 €
63_066d	54618	Bulb 12 Volt, 60/55 Watt, Halogen-H4, socket P45T	7,06 €	8,40 €
63_066e	1354620	Bulb 12 Volt, 60/55 Watt, Halogen-H4, socket P43T Nightbreaker plus 110% light efficiency !	14,62 €	17,40 €
63_066f	78006	Bulb 12 Volt, 35/35 Watt, Halogen-H4, socket PX43T	7,82 €	9,30 €
63_067a	1356402	Chrome rim for BMW R60/6-R100/7, Headlight	39,58 €	47,10 €
63_067b	1243539	Chrome rim for BMW R45, R65 and R80ST, Headlight	95,13 €	113,20 €
63_068a	13013	Headlight lens "H4" for BMW R60/6-R100R	27,65 €	32,90 €
63_068b	1358148	Headlight lens "H4" for BMW R60/6-R100 for LEFT-HAND-TRAFFIC	90,34 €	107,50 €
63_070a	1355396	Reflector headlight for BMW R60/6-R100R and R45/R65	158,57 €	188,70 €
63_070b	1243537	Reflector for halogen headlight for BMW R50/5-R75/5, R45/R65 and R80ST original BMW	176,89 €	210,50 €
63_071	80130	Bulb holder single-pole for position light with H4, socket BA9S	5,38 €	6,40 €
63_073-075	1243227	Indicator complete for BMW RT-Fairing, left side	51,85 €	61,70 €
63_073-075	1243228	Indicator complete for BMW RT-Fairing, right side	51,85 €	61,70 €
63_073a	1243233	Indicator light lense for BMW R45T-R100RT, left side	25,13 €	29,90 €
63_074	1244322	Gasket for indicator light lens for BMW R45T-R100RT, left side	12,69 €	15,10 €
63_074	1244321	Gasket for indicator light lens for BMW R45T-R100RT, left side	12,69 €	15,10 €
63_079	1244320	Parking light gasket R45T-R100RT	4,79 €	5,70 €
63_082	33031	Taillight housing for BMW R50/5-R100 until year of manufacture 09/1980 used, new painted	68,32 €	81,30 €
63_084	1351524	Gasket taillight lens for BMW R50-R100 until year of manufacture 09/1978	6,72 €	8,00 €
63_085	78381	Bulb 12 Volt, 21/5 Watt, socket BA15D	2,18 €	2,60 €
63_086	50403	Lens, tail light for BMW R50/5-R100 until year of manufacture 09/1978	23,95 €	28,50 €
63_086b	1350403	Lens, tail light for BMW R50/5-R100 until year of manufacture 09/1978 original BMW	57,31 €	68,20 €



63_087	06760	Screw for tail light lens for BMW R50/5 and up	1,34 €	1,60 €
63_088	43756	Taillight for BMW R45/R65 from 1978 and R80-R100R from 1980, complete also replacement for R50/5-R90S	90,00 €	107,10 €
63_088b	1243520	Wiring harness, tail light for BMW R60/7-R100RT, years of manufacture 09/1977-08/1978	28,49 €	33,90 €
63_089a	1243685	Reflector taillight for BMW R45/R65, R60/7-R100 until year of manufacture 1995	32,77 €	39,00 €
63_090	78381	Bulb 12 Volt, 21/5 Watt, socket BA15D	2,18 €	2,60 €
63_092	43758	Lens, tail light for BMW R45, R65 und R60/7-R100 from year of manufacture 09/1978	25,88 €	30,80 €
63_096	2307242	Indicator light holder for BMW R80R-100R, right side silver	53,19 €	63,30 €
63_096	1244715	Indicator light holder for BMW R80R and R100R, front and rear	8,57 €	10,20 €
63_096a	1243618	Indicator light holder for BMW R50/5-R100, rear stainless steel, polished	38,91 €	46,30 €
63_096b	1244352	Indicator light holder for BMW R50/5-R100, rear, black	41,93 €	49,90 €
63_105	78381	Bulb 12 Volt, 21/5 Watt, socket BA15D	2,18 €	2,60 €
63_106	1244080	Gasket taillight for BMW R65GS-R100GS, years of manufacture 1980-1992	6,47 €	7,70 €
63_999	98102	Screw for bar end indicator lens, M 3 x 10	0,08 €	0,10 €
63_999	2006	Bar end indicator, Hella (Bull's eye) aluminium polished	53,53 €	63,70 €
63_999	1350492	Grommet taillight for BMW R50/5-R100RT	3,28 €	3,90 €

Group 95 Literature, bits and pieces

<u>Article-No.</u>	<u>Description</u>	<u>Net</u>	<u>Gross</u>
9799000	Repair manual for BMW R80GS-R100R years of manufacture 1991-1996 (GERMAN LANGUAGE) original BMW	60,75 €	65,00 €
9010	Cable tape 150x3,6mm black	0,08 €	0,10 €
067175	Goggle Jeanted T1/2 Spare glasses set, mirrored-glass	34,54 €	41,10 €
9798350	Repair manual for BMW R80G/S from year of manufacture 09/1980 (GERMAN LANGUAGE) original BMW	39,63 €	42,40 €
068002	Goggle Aviator Vintage, leather chrome	146,30 €	174,10 €
27028	Owner's manual for BMW R45 and R65 (GERMAN LANGUAGE)	23,36 €	25,00 €
27029	Owner's manual for BMW R45, R65 and R65LS (GERMAN LANGUAGE)	23,36 €	25,00 €
27030	Repair manual for BMW R45/R65 until year of manufacture 09/1984 Model 82/83	58,88 €	63,00 €
9796330	Spare parts catalogue for BMW R45 and R65 in GERMAN	40,19 €	43,00 €
9798270	Owner's manual for BMW R80RT-R100RT until year of manufacture 09/1984 (GERMAN LANGUAGE)	16,07 €	17,20 €
67062	Goggle Aviator Retro, leather chrome	125,55 €	149,40 €
61250	Google alternate strap T1/T2	27,73 €	33,00 €
366300	Sonax Motorrad cleaner ,1L spray bottle	12,52 €	14,90 €
366341	Sonax Motorrad cleaner, 1L replacement-bottle	11,18 €	13,30 €
24000	Fuel tank seal mastic "Tankcure", 450g for one fuel tank ! (up to 24L tank)	29,41 €	35,00 €
60327	Goggle-Classic for half-shell helmet, chrome frame, black	34,54 €	41,10 €
04119	Goggle Aviator Retro optical chrome, for spectacle wearer	177,48 €	211,20 €
13070	Varnish pen, black	9,33 €	11,10 €
27026	Owner's manual for BMW R60/6-R90S - ENGLISH LANGUAGE	26,64 €	28,50 €
24003	Helmet Jet, fiberglass, black/silver, no ECE, S extra small shell, brown leather lining	77,90 €	92,70 €
04114	Goggle Aviator Retro, natural rubber chrome	113,36 €	134,90 €
022001	Rust remover "Tankcure"	15,55 €	18,50 €
9015	Cable strap 150x3,6mm black	0,17 €	0,20 €
9019	Cable tape 360x7,5mm black	0,50 €	0,60 €
336201	Sonax Gasket remover, 300ml	9,16 €	10,90 €
4008	Spare parts catalogue for BMW R5 and R6 in GERMAN	26,82 €	28,70 €
999401	Test light, 6-24 Volt	8,74 €	10,40 €
90190	Cable tape 285 x 4,7	0,17 €	0,20 €
5025	Cleaner for stainless steel, 250ml spraybottle	12,94 €	15,40 €
15057	Repair manual for BMW R80R and R100R (GERMAN LANGUAGE)	37,29 €	39,90 €
1083	Polishing wadding Nevr Dull	7,06 €	8,40 €
96165	List of models R32-R100RS, with data copy	2,15 €	2,30 €
04116	Goggle Aviator Spare glasses set, yellow	13,78 €	16,40 €
9017	Cabel strap 200 x 3,6 mm black	0,17 €	0,20 €
9798860	Repair manual for BMW R65-R100RT years of manufacture 09/1984-1995 (GERMAN LANGUAGE) original BMW	71,12 €	76,10 €
0411401	Goggle Aviator Retro, natural rubber gunmetal	113,36 €	134,90 €
4600210	Goggle alternate strap Aviator Retro	21,60 €	25,70 €
0501501	Goggle Cilmax 501, leather chrome	58,57 €	69,70 €
0067174	Google Jeanted T1/2 Spare glasses Set, tinted glass	21,68 €	25,80 €
9798861	Repair manual for BMW R65-R100RT years of manufacture 1984-1995 (ENGLISH LANGUAGE)	64,21 €	68,70 €
0004116	Goggle Aviator Retro Spare glasses Set, clear	14,62 €	17,40 €
9799070	Owner's manual for BMW R80R-R100R from year of manufacture 08/1992 (GERMAN LANGUAGE)	21,78 €	23,30 €



1889254	Helmet Jet, fiberglass, black/silver, no ECE, L extra small shell, brown leather lining	77,90 €	92,70 €
1889255	Helmet Jet, fiberglass, black/silver, no ECE, XL extra small shell, brown leather lining	77,90 €	92,70 €
1889265	Helmet Jet, fiberglass, green/silver, no ECE, XL extra small shell, brown leather lining	77,90 €	92,70 €
1004116	Goggle Aviator Retro Spare glasses set, smoke	13,78 €	16,40 €
2233444	Rust remover "FERTAN", 250ml No shipment outside the European Union possible!	16,05 €	19,10 €
9019000	Cable tape 300 x 4,6 mm, stainless steel	0,67 €	0,80 €
9796332	Auxiliary Catalogue for BMW R50/5-R100RT FOUR languages in ONE book: German, English, Dutch, Swedish, original BMW	52,52 €	56,20 €
998376	Total Power Grease, Innotec Spray-fat	14,03 €	16,70 €
70210	Owner's manual for BMW R50/5-R75/5 (GERMAN LANGUAGE)	23,36 €	25,00 €
4026	Spare parts catalogue for BMW R50-R69S (German, English, French)	17,65 €	21,00 €
30685	Tool set for BMW R50/5-R100 until year of manufacture 1984 21 pieces, original BMW	131,93 €	157,00 €
70211	Owner's manual for BMW R60/6-R90S (GERMAN LANGUAGE)	23,36 €	25,00 €
70212	Owner's manual for BMW R60/7-R100RS (GERMAN LANGUAGE)	23,36 €	25,00 €
70219	Spare parts catalogue for BMW R51, R61, R66 and R71 IN GERMAN	26,82 €	28,70 €
98740	Owner's manual for BMW R65-R100RT from year of manufacture 1985 (GERMAN LANGUAGE) original BMW	18,22 €	19,50 €
9029	Spare parts catalogue for BMW R51/2 in GERMAN	18,13 €	19,40 €
9028	Spare parts catalogue for BMW R51/3-R67/3 IN GERMAN	18,13 €	19,40 €
9099140	Spare parts catalogue for BMW R50/5, R60/5 and R75/5 in GERMAN	37,48 €	40,10 €
4057	Spare parts catalogue for BMW R57 and R63 IN GERMAN	23,46 €	25,10 €
1004	Repair manual for BMW R60/7-R100RS until years of manufacture 1982/1983 (GERMAN LANGUAGE)	68,50 €	73,30 €
9020	Spare parts catalogue for BMW R68 in GERMAN	18,13 €	19,40 €
4003	Spare parts catalogue for BMW R75 Wehrmacht with side car IN GERMAN, REMNANTS	32,15 €	34,40 €
1001	Repair manual for BMW R50/5, R60/5 and R75/5 (GERMAN LANGUAGE)	46,07 €	49,30 €
4001	Spare parts catalogue for STEIB sidecars in GERMAN	28,97 €	31,00 €
1000	Repair manual for BMW R60/6-R90S (GERMAN LANGUAGE)	41,78 €	44,70 €
1002	Repair manual for BMW R45 and R65 years of manufacture 1978-1980 (GERMAN LANGUAGE)	37,29 €	39,90 €
3002	Repair manual for BMW R60/7-R100RT years of manufacture 1976-1980 (GERMAN LANGUAGE)	37,29 €	39,90 €
9798461	Repair manual for BMW R60/7-R100RS (ENGLISH LANGUAGE)	41,21 €	44,10 €
27025	Owner's manual for BMW R50/5-R75/5 - ENGLISH LANGUAGE	35,23 €	37,70 €
9796621	Auxiliary Catalogue for BMW R100-R100RT, GERMAN language original BMW	28,50 €	30,50 €
70218	Spare parts catalogue for BMW R11 and R16 series 1/5 IN GERMAN	26,26 €	28,10 €
872042	Book: "Schrader-Motor-Chronik, BMW-Motorräder Singles, Boxer-, GS- und K-Modelle seit 1970", GERMAN A documentation from Jan Leek, 1.edition 2007	21,31 €	22,80 €
0872041	Book: "Schrader-Motor-Chronik, BMW-Motorräder seit 1970, Singles, Boxer- und K-Modelle", GERMAN LANG A documentation from Jan Leek, 1.edition 2000	21,31 €	22,80 €
01558	Book: "BMW Motorräder seit 1923", GERMAN LANGUAGE from Wolfgang Zeyen and Jan Leek, 1.Edition 2004	53,46 €	57,20 €
01955	Book: "Typenkompass, BMW, Motorräder seit 1945", GERMAN LANGUAGE from Jan Leek, 1.Edition 2012	11,21 €	12,00 €
0035942	Book: "Schrader-Typen-Chronik, BMW Zweiventiler Motorräder 1969 - 1996", GERMAN LANGUAGE A documentation from Andy Schwietzer, 1.Edition 2011	12,10 €	12,95 €
87134	Book: "BMW-Zweiventiler von 1969 bis 1985, Boxer ab /5, Band 1" GERMAN LANGUAGE from Andy Schwietzer, 3. revised and replished Edition 2008	31,96 €	34,20 €
0025485	Book: "Der Kupferwurm" and "Besser machen, Arbeiten an Motorrädern" in one Vol. , GERMAN LANGUAGE from Carl Hertweck, special Edition: 2. Edition 2006	42,71 €	45,70 €
9806631	Book: "BMW-Zweiventiler von 1980 bis 1996, Boxer ab R80G/S, Band 2" GERMAN LANGUAGE from Andy Schwietzer, 1.Edition 2008	31,96 €	34,20 €
3038028	Book: "BMW-Motorräder, Die Jahrhundert-Story", GERMAN LANGUAGE from Frank Rönicke, 1. Edition 2015	32,06 €	34,30 €
3038806	Book: "BMW Boxer, Die Zweiventil-Twins 1969-1996", GERMAN LANGUAGE from Ian Falloon, 1. Edition 2016	27,94 €	29,90 €
8066319	Book: "BMW-Zweiventiler von 1969 bis 1996, Boxer Technik, Band 3" GERMAN LANGUAGE from Helmut Heusler, 2.ext.Edition 08/2013	41,78 €	44,70 €
1885648	Helmet half shell, fiberglass, black, chequered, S	69,16 €	82,30 €
1889122	Helmet half shell, fiberglass, black, chequered, M	69,16 €	82,30 €
1889202	Helmet Jet, ECE-22.05, black, S	60,59 €	72,10 €
1889204	Helmet Jet, ECE-22.05, black, L	60,59 €	72,10 €
1889215	Helmet Jet, ECE-22.05, white, XL	60,59 €	72,10 €
1889216	Helmet Jet, ECE-22.05, white, XXL	60,59 €	72,10 €
1889225	Helmet Jet, ECE-22.05, white, chrome-edge, XL black textile lining, REMNANT STOCK!	86,55 €	103,00 €
1889226	Helmet Jet, ECE-22.05, white, chrome-edge, XXL black textile lining, REMNANT STOCK!	86,55 €	103,00 €
1889702	Helmet Jet, ECE-22.05, black, chequered, S black textile lining	86,47 €	102,90 €
1889703	Helmet Jet, ECE-22.05, black, chequered, M black textile lining	86,47 €	102,90 €
1889704	Helmet Jet, ECE-22.05, black, chequered, L black textile lining	95,13 €	113,20 €
4006	Spare parts catalogue for BMW R20 and R23 IN GERMAN	20,56 €	22,00 €
9022	Spare parts catalogue for BMW R25 IN GERMAN	18,13 €	19,40 €



9021	Spare parts catalogue for BMW R24 in GERMAN	18,13 €	19,40 €
9024	Spare parts catalogue for BMW R25/3 in GERMAN	18,13 €	19,40 €
9025	Spare parts catalogue for BMW R26 and R27 in GERMAN	19,63 €	21,00 €
4012	Spare part catalogue for BMW R12 and R17 IN GERMAN	22,24 €	23,80 €
4004	Spare parts catalogue for BMW R35 in GERMAN	20,56 €	22,00 €
9023	Spare parts catalogue for BMW R25/2 in GERMAN	18,13 €	19,40 €
09002	Booklet: Chart about BMW R25/2 and R51/3	8,13 €	8,70 €
010980	Sonax Power-glue Teroson 3g tube	3,45 €	4,10 €
30752	Tool bag, 19cm high WITHOUT CONTENT	11,18 €	13,30 €
10020	Booklet: Service and repair of the electrical system (GERMAN LANGUAGE) for BMW R24-R25/3 and R51/3-R69S, 6V and 12V	8,66 €	10,30 €
00040	WD-40, anti-rost Spray 400ml	7,82 €	9,30 €
3075217	Tool bag, 17cm high WITHOUT CONTENT	11,18 €	13,30 €
3075215	Tool bag, 15cm high WITHOUT CONTENT	11,18 €	13,30 €
0106740	Start pilot (start-up aid), 300ml	6,22 €	7,40 €
7131139	Rider's mask, black, cotton	4,37 €	5,20 €
8961034	Folding leaf sight, toned for jet helmets with 3 button fixing, REMNANTS	23,36 €	27,80 €



In order to accomplish a fast dispatch, we ask you to give to us your credit card details

Please fill out this side and **fax it to us at +49 69 23 38 40**

Credit card direct debit authorisation

Hereby I authorize

Ulis Motorradladen GmbH
Gutleutstrasse 144
D-60327 Frankfurt am Main

to deduct invoice amounts of my credit card account.

Name.....

Customer's number (if known).....

Street.....

ZIP / Town / State / Country.....

Name of Account owner.....

Name of the bank.....

Credit card number.....

Date of expiration.....

CV code (three digits on the back of your card in the signature area).....

Date / Signature.....



How to find us

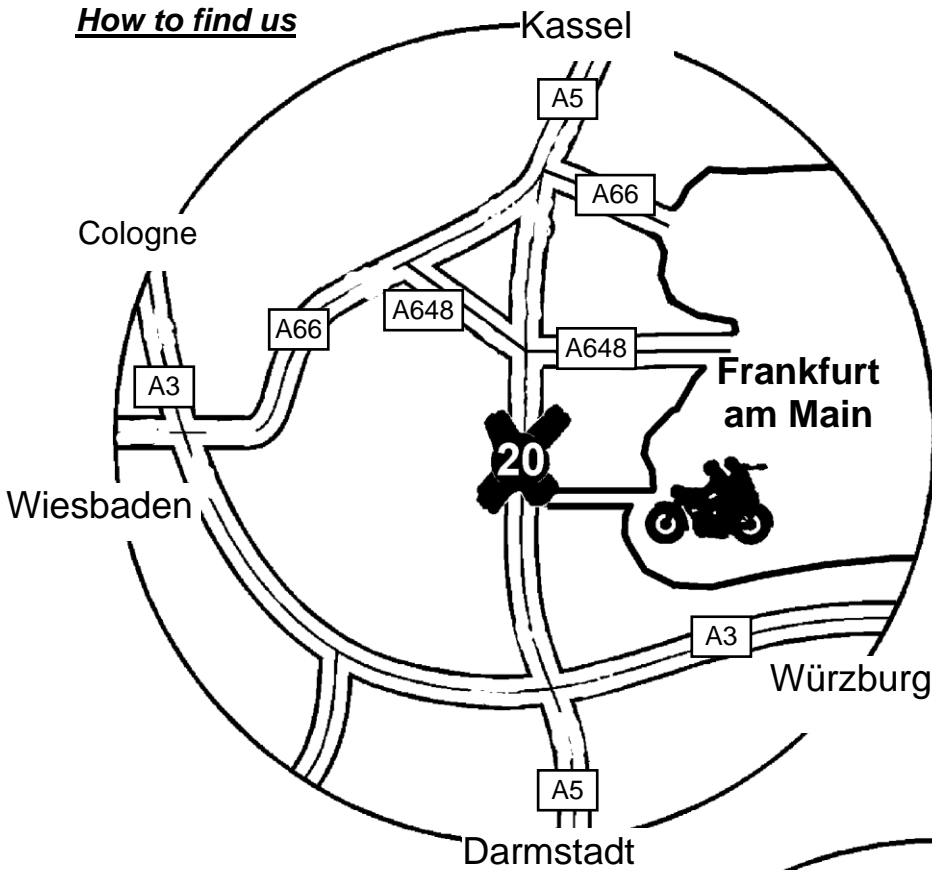

Attention!
The exit 20 – WESTHAFEN can only be used when you are coming from the North.

If you are coming from the South, you have to make a U - Turn at the WESTKREUZ
First direction WIESBADEN, then direction BASEL

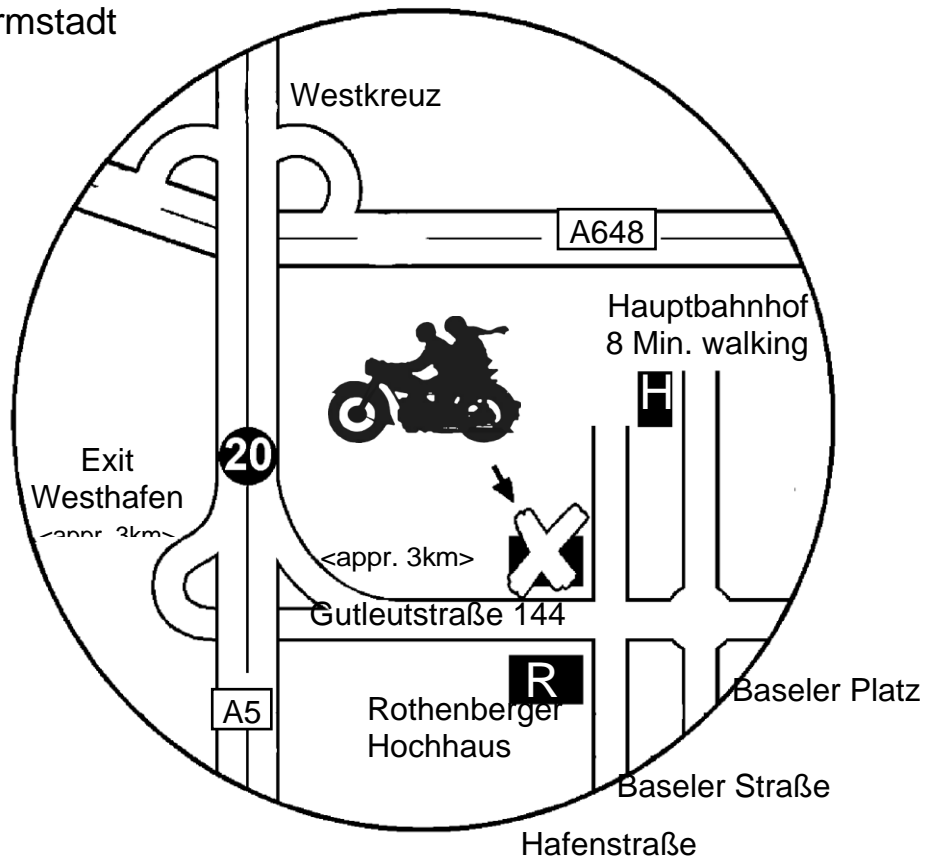

Ulis Motorradladen GmbH

Gutleutstrasse 144
D – 60327 Frankfurt am Main
Germany

Telefon +49 (69) 23 93 19
Telefax +49 (69) 23 38 40

Info@UlisMotorradladen.de
www.UlisMotorradladen.de

WGS84:
50°06'27"North / 08°38'47"East

We're open:
Tu-Fr 10:00-18:30 / Sat 10:00-13:00