



Ulis Motorradladen

BMW Motorcycles

Spare Parts

Accessory

CATALOGUE 2018

BMW R24 to R69S - 1949 to 1969

Table of content:

Terms and Conditions	3
Impressum	5
Group M: Engine all Singles	6
Group N: Engine housing, Cylinder, Piston all Twins	12
Group W: Inner engine parts all Twins	16
Group G: Gearbox all Singles	23
Group H: Gearbox all Twins 1955-1969	27
Group I: Gearbox all Twins 1948-1956	31
Group K: Rear transmission R25, R25/2, R25/3	34
Group C: Rear transmission all Twins 1948-1956	36
Group P: Rear swing arm and transmission all models 1955-1969	38
Group T: Fork and steering R24, R25, R25/2	42
Group Q: Fork and steering R25/3	45
Group R: Fork and steering R51/2-R68	48
Group S: Front swing and steering all models 1955-1969, rims, spokes, tires	52
Group F: Frame, fenders, tank, seats all models 1948-1956	59
Group J: Frame, fender, tank, seat for all models 1955-1969	66
Group A: Exhaust system all models 1948-1969	73
Group E: Electrics	76
Group V: Carburetor, airfilter all models 1948-1969	84
Group Z: Sidecar spare parts	88
Group L: Literature, Manuals	91
Credit card direct debit authorisation	94
How to find Ulis Motorradladen	95

Ulis Motorradladen GmbH
Gutleutstrasse 144
D-60327 Frankfurt am Main
Germany

Telefon +49 (0) 69 / 17536440
Telefax +49 (0) 69 / 175364499
Info@UlisMotorradladen.de
www.UlisMotorradladen.de
www.UlisMotorradladen.com

Shop is open:

Tuesday to Friday from 10:00 – 12.30 and 13.30 – 18.00
Saturday 10.00 -- 13:00, Sunday and Monday closed.

**The direct line to your needs**

At the times indicated, the responsible employees deal exclusively with your calls. That enough lines are free and therefore longer waiting times are avoided, please call always the fitting number for your needs from the following overview.

Sale - spare parts - The Hotline for your orders!

Tuesday - Friday : 10.00 a.m. to 12.00 noon and 3.00 p.m. to 5.00 p.m.
Saturday : 10.00 a.m. to 1.00 p.m.
Tel.: 0049 (0) 69-1753644-10

Technical consulting - Technical questions about our products

Tuesday - Friday : 5.00 p.m. to 5.30 p.m.
Tel.: 0049 (0) 69-1753644-30

Ebay settlement - with questions about a purchase on Ebay

Tuesday - Friday : 10.00 a.m. to 12.00 noon
Tel.: 0049 (0) 69-1753644-11

IT / Online Store - login problems or questions regarding the use

Tuesday - Friday : 10.00 a.m. to 12.00 noon and 3.00 p.m. to 5.00 p.m.
Tel.: 0049 (0) 69-1753644-42

Additional departments

Tuesday - Friday : 10.00 a.m. to 12.00 noon and 3.00 p.m. to 5.00 p.m.

Switchboard

Here you can call if you are not sure which department is responsible for your concern. They connect you to the appropriate contact person.
Tel.: 0049 (0) 69-1753644-0

Shipping

For questions about a package which is on the way to you, the employees can help you here.
Tel.: 0049 (0) 69-1753644-12

Repairs/Workshop

If you want to repair a motorcycle or parts thereof, or have a bike/part with us for repair, you can contact us with your concerns here.
Tel.: 0049 (0) 69-1753644-31

Purchase

If you are a supplier of us, or want to be, that's the correct number:
Tel.: 0049 (0) 69-1753644-20

Accounting

For questions about a payment or reminder you can call here:
Tel.: 0049 (0) 69-1753644-41

Fax: 00 49 (0)69 - 1753644-99

E-Mail: Info@UlisMotorradladen.de



Dear BMW friends and riders,

Welcome to Ulis Motorradladen!

Thank you for your interest in our products for older BMW motorcycles. This is our latest edition of an English version of our catalog, we hope this edition will help you locate your parts more easily. Parts descriptions are translated in English language. We apologize for mistakes beforehand.

A note to owners of BMW motorcycles built after 1969: We stock nearly all spare parts for these models and we have a catalog for them exclusively. All catalogs are available for download from our web-site as zipped .pdf files. All software tools to unzip and read them are free and readily available.

In this catalog you'll see each part category preceded by a diagram. By cross-referring a part description with the picture in the diagram, we hope to eliminate misunderstandings and incorrect part orders. The diagrams and listings also show that we do indeed keep all parts for old BMWs in stock and ready for shipment.

Please notice that we offer many used parts. We do not sell junk—rather good, useable parts. For example, if you order a used crankcase breather for a R60/6, the part you receive will in no way be inferior to a new factory part. The price of a used part is generally half the price of the new part. Exceptions to this are rare parts that are no longer available.

We are a customer-oriented company. If you have technical questions regarding your BMW we are happy to answer them. We have been riding, servicing and selling old BMWs for years—we are experts regarding what we sell. We answer all inquiries in the order they are received and as soon as possible. Suggestions are always welcome!

Terms and Conditions

The shipping-cost will be charged according to the conditions displayed in a list you will find on our website under www.ulismotorradladen.de or in conjunction with an online-order you place.

The forwarder and the shipping-method we will determine for you, depending on the nature of the goods you buy.

All shipments however are insured against loss.

The payment-method „COD cost on delivery“ will result in an extra fee (see shipping-cost list).

Online-orders include the shipping-cost and all additions and will be processed when you confirm the order.

Please notice:

Every order will result in shipping-cost, no matter if you order few or many items. No shipment will be transport-fee free.

The shipping-cost includes the German VAT in any case, which is no error.

The average runtime within Germany is 1-5 labourdays.

The average runtime in foreign countries varies from 5-60 labourdays, depending on the destination.

Due to specific conditions in the land of the destination (holidays, weather-conditions, legal conditions) delays can occur and cannot be influenced by Uli's..

Uli's cannot guarantee that the parcel will arrive in time. The shipping-companies themselves do not guarantee the delivery within the standard-runtime, unless you do not order additional service performances.

Special shipping-performances can be ordered, resulting in additional freight-cost, such as EXPRESS-shipments or courier services. The cost and the equivalent conditions can be asked for at Uli's helpdesk.

We are capable to ship complete motorcycles, sidecars and combinations as well. Cost and delivery conditions under request.

Payment Conditions

- Bankdraft:

We draw the total from your bank-account, if it is bank in Germany. You do not have to care or worry for anything.

The quickest and most convenient way to pay. Bankdraft from banks outside of Germany are not possible.

- Creditcard:

Please transfer your creditcard details to us, We need the long number, expiry-date and the 3-digit security-code. Do not use email to transmit the data! Only Fax, telephone and our webshop are safe. We accept Visa-Euro-Master-Amexcard. Maestro- or bankingcards are not valid.

- Prior payment

We will send an email (or Fax) to you, including an order-confirmation with a detailed list of what you buy and the total cost all together. If you transfer the money to one of our bank-accounts, the goods will be sent out without delay.

Using the online-shop, you can proceed with the payment as soon as the buying process is finished. Mention the document-number, please.

Reparation of Components

If you send in components of motorcycles for reparation, please do not forget to include a detailed description of the labour you want us to perform. Without such a description, the work cannot be done.

Please clean the parts before you send them in. If you should fail to do so, we would probably have to charge an additional cleaning-fee. Pack the things carefully, many valuable parts break or get scratched due to improper packing. The letter you send with the component must also include your full name and home-address.

**Repeal**

It is your privilege as a end-customer to repeal the contract within the first 14 days after your purchase. This right is only valid if we had sent the parts to you, not if you had bought them in our shop locality. Please declare your repeal within 14 days in written form (a.e. letter, fax, email) or by phone.

Send the Reapeal to:

Ulis Motorradladen GmbH
Gutleutstrasse 144
60327 Frankfurt
Germany
Email: info@ulismotorradladen.de
Fax: 0049 - 69 - 1753644 - 99
Phone: 0049 - 69 - 1753644 - 0

You can claim back the full amount, if:

- the commodity has been bought at Uli's,
- the goods are not damaged
- the goods have not been used, regardless of minor traces of usual inspections

Parts that have been used or damaged might not be subject for a refund or for claims. In some cases, we would refund the value with an equivalent decuction.

The return-shipping-cost will not be covered by Uli's, you must pay them.

This return-shipping-costs are displayed in our online shop, befor you send the order in the last step.

They will be:

EUR 7,65 inside germany

EUR 20,90 from all other european continent countrys

EUR 44,50 from all countrys outside the european continent.

If you must pay more shipping fee for a standard parcel, we will refund this more costs.

The refund of the money must be do within 14 days.

No Repeal for bussiness customers, clubs and societys.

If you have the wish to send back goods, please ask us before!

No Repeal if you bought the good in our local shop.

If you have the wish to send back goods, please ask us before!

Exchange

The condition for an exchange of a commodity is that the goods have returned to Uli's.

The goods you return will be subject to a credit, and the parts you want to buy instead will be charged as usual.

Reclamation

Everything you buy at Uli's includes „Gewährleistung“, which means that you have the right to claim a broken, defective or unfunctional product alt Uli's up to a period of 24 months, but only if we had sent the part to you. If you had picked up the commodity in our shop locality, the right is invalid.

The right mentioned above is valid 12 moths only if the commodity is secondhand.

Of course we inspect all secondhand and used parts thoroughly before we sell them.

In case of a righteous reclamation of goods, Uli's will cover all transportation-fees, also for their return.

Your shipmets to us

will be accepted under the condition that the transportation-fee has been paid for. Shipments that include a duty for Uli's will be refused. Exemptions are made if the return is subject to an agreement with Uli's.

If it should be your wish not to expend transportation-fees prior to the return, we would like you to get in contact with us.

Uli's has means to organize reasonable collect-services. If you should fail to contact us before you send in a parcel with a duty for Uli's, we would probably deduct the cost from later refunds. Please do not send „unfree“ parcels!

Prices

All pricelists in connection with Uli's Motorradladen, such as the PDF-file you find under www.ulismotorradladen.de include reserved prices. Changes in prices can and will occur. We do not guarantee for printed prices.

The prices in the online-shop are currently adopted and valid in general.

Every pricelist includes prices with VAT and without VAT. All prices are in Euro. Pricelists in other currencies than EURO do not exist. Also, the invoices we set up are in EURO exclusively.

Best Regards,

Schöne Grüße aus Frankfurt,

Ulis Motorradladen



Impressum

Ulis Motorradladen GmbH

BMW Motorräder – Ersatzteile – Zubehör
Gutleutstrasse 144

D-60327 Frankfurt am Main
Germany

Telefon +49 (69) 1753644-0
Telefax +49 (69) 1753644-99
eMail Info@UlisMotorradladen.de
Internet <http://www.UlisMotorradladen.de>
<http://www.UlisMotorradladen.com>

Managing director Ulrich Seiwert
District court Frankfurt HRB40289
VAT-No: / UstIdNr: DE 174059929

Payments can be transfered to:

Postgiroamt Frankfurt
Account No 11 52 38-608
Bank Id No 500 100 60
Iban:DE43500100600115238608
SwiftBic: PBNK DE FF

Commerzbank Frankfurt
Account No 384 766 400
Bank Id No 500 800 00
Iban:DE67500800000384766400
SwiftBic: DRES DE FF

Copyright @ Ulis Motorradladen GmbH 2018.

Reprint, copying or any kind of publishing – even parts of it – needs our written permission!

We apologize for all possible mistakes and price changes.



Group M: Engine all Singles

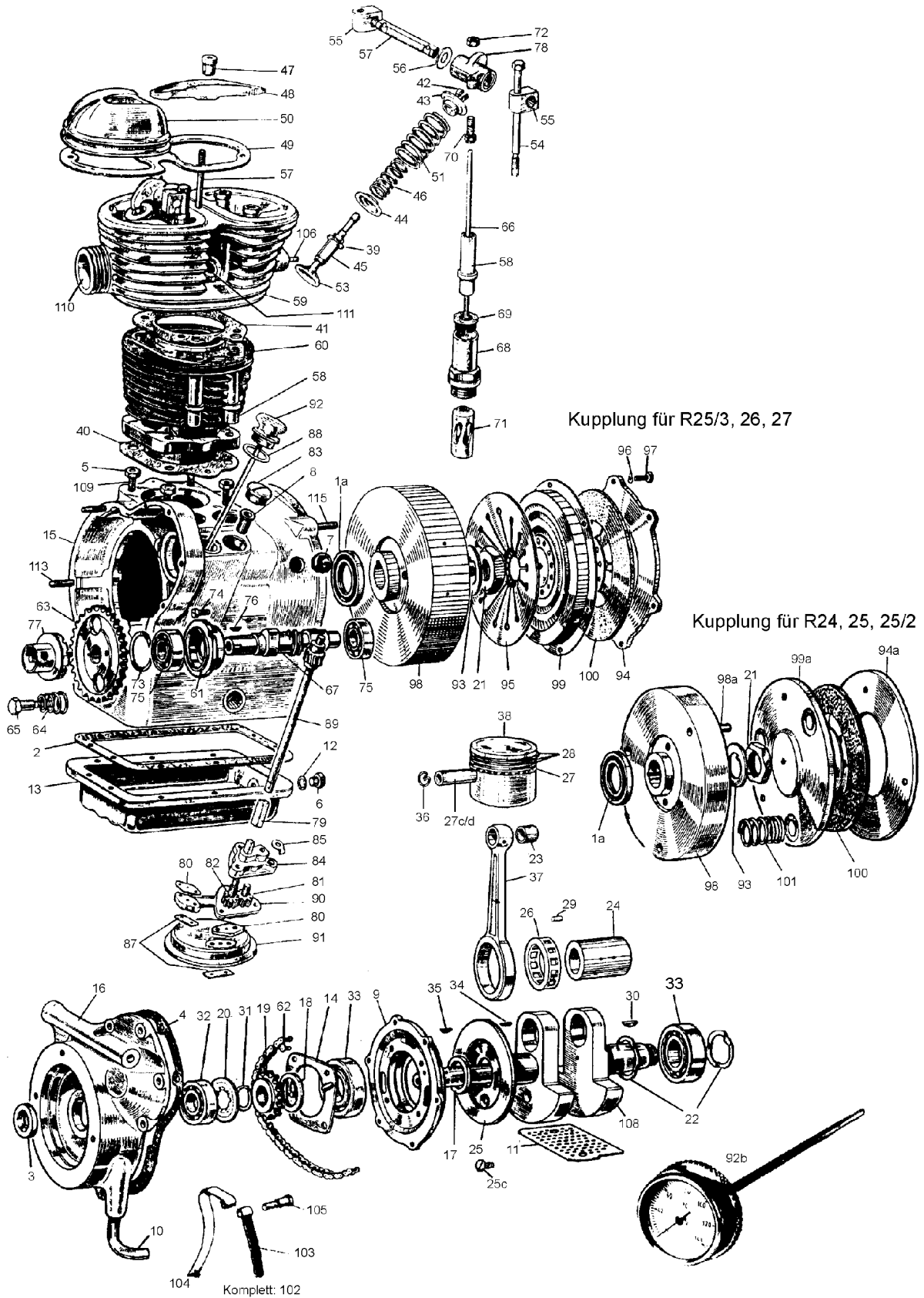

Picture-No.	Article-No.	Description	Net	Gross
M000	600014	Engine gasket set (No.M01) for BMW R24 and R25, complete	26,47 €	31,50 €
M000A	600003	Engine gasket set (No.M02), for BMW R25/2 and R25/3	26,47 €	31,50 €
M000B	600008	Engine gasket set (No.M03), for BMW R26, complete	26,47 €	31,50 €
M000C	600009	Engine gasket set (No.M04) for BMW R27, complete	31,72 €	37,75 €
M001	01124	Radial seal ring, crankshaft rear for BMW R26, R27 and R51/3-R69S, silicon white, with spin	13,36 €	15,90 €
M001A	07100	Radial seal ring, crankshaft rear for BMW R24, R25, R25/2 and R25/3	7,44 €	8,85 €
M001A	01123	Radial seal ring, crankshaft rear for BMW R26, R27 and R51/3-R69S, silicone white	10,76 €	12,80 €



M001A	01122	Radial seal ring, crankshaft rear for BMW R26, R27 and R51/3-R69S	8,82 €	10,50 €
M001A	0112201	Radial seal ring, crankshaft rear for BMW R26, R27 and R51/3-R69S, "VITON" with spin	17,23 €	20,50 €
M001D	99177	Repair-Set for flywheel seal-seat for BMW R24, R25, R25/3 and R25/3	36,89 €	43,90 €
M001E	99204	Repair-Set for flywheel seal-seat for BMW R26, R27 and R51/3-R69S	41,93 €	49,90 €
M002	01104	Oil pan gasket for BMW R24-R27, Cork	3,32 €	3,95 €
M002	0001104	Oil pan gasket for BMW R24-R27, Paper	3,32 €	3,95 €
M003	02129	Radial seal ring camshaft for BMW R27	3,53 €	4,20 €
M003	02110	Radial seal ring, crankshaft front for BMW R24-R27	4,03 €	4,80 €
M003B	1002127		16,39 €	19,50 €
M004	02114	Timing cover gasket for BMW R24-R27	2,69 €	3,20 €
M005A	37789	Cylinder base 12-point nut for cardan coupling	2,31 €	2,75 €
M005B	85002	Cylinder base nut 6-point for BMW R24-R60S, wrench size 14mm, M10 zincked	1,51 €	1,80 €
M005C	98370	Cylinder base nut 6-point for BMW R24-R60S, wrench size 14mm, M10 stainless steel	2,35 €	2,80 €
M006	07163	Oil drain screw for BMW R24-R69S, M14, magnetic zincked	3,19 €	3,80 €
M006	62893	Oil drain screw, M15 x 1,5	5,80 €	6,90 €
M006B	62892	Oil drain screw, M16	6,30 €	7,50 €
M007A	01106	Rubber plug for timing control hole, black for BMW R25-R69S and R50/5-R100	1,26 €	1,50 €
M007B	43016	Rubber plug for timing control hole, white for BMW R25-R69S and R50/5-R100	1,26 €	1,50 €
M008	01112	Bushing oil pump shaft for BMW R24-R27	8,32 €	9,90 €
M009	9913470	Screw for bearing plate 1-cylinder and alternator cover BMW R51/2, M 6 x 18, hexagon	0,30 €	0,36 €
M009A	90031	Bearing shield crank shaft for BMW R24 and R25, front aluminium, used	65,55 €	78,00 €
M009B	02104	Bearing shield crank shaft for BMW R25-R27, front NEW	91,39 €	108,75 €
M010	01114	Engine breather pipe for BMW R24, R25, R26 and R27 zincked	10,76 €	12,80 €
M011	01116	Screen plate engine for BMW R24-R69S used - please indicate typ!!!	7,39 €	8,79 €
M012	2027	Gasket ring oil drain screw, M14x20x2	0,67 €	0,80 €
M013	07000	Oil pan for BMW R24-R27 with distance piece for oil screen, bigger version Capacity: ca. 1,75 liter (instead of 1,25 liter), aluminium	74,96 €	89,20 €
M014	02124	Flange for front bearing cover for BMW R24-R27 used	16,72 €	19,90 €
M015A	01009	Engine housing for BMW R25, R25/2 and R25/3 used	159,66 €	190,00 €
M015B	01008	Engine housing for BMW R26 used	268,91 €	320,00 €
M015C	01007	Engine housing for BMW R27 used	268,91 €	320,00 €
M016	4031	Timing cover for BMW R24-R26 used	41,93 €	49,90 €
M016	5031	Timing cover for BMW R27 used	100,84 €	120,00 €
M017	0016114	Spacer ring on crankshaft between chainwheel and bearing for BMW R24-R27 new old stock + new produced	3,36 €	4,00 €
M018	0016116	Spacer ring on crankshaft between chainwheel and bearing for BMW R24, R25, R25/2 and R25/3	5,46 €	6,50 €
M019	16500	Chain wheel crankshaft for BMW R26 and R27 Original BMW-NEW PART	50,34 €	59,90 €
M019	1611801	Chain wheel crank shaft for BMW R24, R25, R25/2 and R25/3 New Old Stock	50,34 €	59,90 €
M019A	16118	Chain wheel crankshaft for BMW R24, R25, R25/2 and R25/3 used	29,37 €	34,95 €
M020	16120	Splash guard crank shaft bearing for BMW R24-R27, front	4,03 €	4,80 €
M021	16122	Fly wheel screw for BMW R24-R27	2,94 €	3,50 €
M022A	16124	Spring washer for crankshaft for BMW R25, R25/2 and R25/3, rear	2,06 €	2,45 €
M022B	16130	Spring washer for crankshaft for BMW R26, R27 and R50-R69S, rear	2,27 €	2,70 €
M023	4027	Piston pin bushing for BMW R24-R25/3 and R51/2-R67/3 18mm	7,39 €	8,80 €
M023	3027	Piston pin bushing for BMW R26, R27, R68 and R50-R69S 20mm	7,39 €	8,80 €
M024	16551	Crank pin for BMW R24, R25, R26 and R27	24,58 €	29,25 €
M025	00106	Screw for oil slinger for BMW R24-R69S	0,46 €	0,55 €
M025A	16119	Oil slinger for BMW R26 "new" and R27	12,52 €	14,90 €
M025B	16112	Oil slinger for BMW R25, R25/2, R25/3 and R26 "old"	12,52 €	14,90 €
M026A	16125	Roller cage for 5mm rollers, small version	28,11 €	33,45 €
M026B	17004	Roller cage for 7mm rollers for BMW R25, R25/2, R25/3, R26 and R27 used	25,13 €	29,90 €
M027A	14217	Piston ring - 68,00-70,50mm, compression define your needed oversize!!!	7,23 €	8,60 €
M027A	1142171	Piston ring - 69,00mm, compression 1st ring	7,23 €	8,60 €
M027A	1014217	Piston ring - 68,00mm, compression 1st ring, chrome plated	7,23 €	8,60 €
M027A	2014217	Piston ring - 68,00mm, compression 2nd ring	7,23 €	8,60 €
M027B	14160	Piston ring - 68,00 - 70,50mm, oil scraper ring please indicate size!!!	10,25 €	12,20 €
M027C	40822	Piston pin - 18mm for BMW R24-R68	8,19 €	9,75 €
M028	14330	Piston ring set (3 pcs) - 68,00-70,00mm please indicate size!!!	24,20 €	28,80 €
M029A	16824	Conrod roller 5x10	0,41 €	0,49 €
M029B	168245	Conrod roller 5x10 +0,04 overmeasure	0,41 €	0,49 €
M029B	168246	Conrod roller 5x10 +0,05 overmeasure	0,41 €	0,49 €
M029B	168244	Conrod roller 5x10 +0,03 overmeasure	0,41 €	0,49 €
M029B	168243	Conrod roller 5x10 +0,02 overmeasure	0,41 €	0,49 €
M029B	168241	Conrod roller 5x10 +0,01 overmeasure	0,41 €	0,49 €
M029C	168247	Conrod roller 7x10 +0,02 overmeasure	0,41 €	0,49 €



M029C	168248	Conrod roller 7x10 +0,03 overmeasure	0,41 €	0,49 €
M029C	168249	Conrod roller 7x10 +0,04 overmeasure	0,41 €	0,49 €
M029C	168250	Conrod roller 7x10 +0,05 overmeasure	0,41 €	0,49 €
M029C	168250	Conrod roller 7x10 +0,05 overmeasure	40,00 €	47,60 €
M029C	168250	Conrod roller 7x10 +0,05 overmeasure	50,00 €	59,50 €
M029C	16140	Conrod roller 7x10	0,41 €	0,49 €
M029D	168242	Conrod roller 7x10 +0,01 overmeasure	0,41 €	0,49 €
M030A	16132	Woodruff key crank shaft for BMW R25/3-R69S, rear	2,10 €	2,50 €
M030B	5148001	Woodruff key for crank shaft BMW R24, R25 and R25/2, rear	1,51 €	1,80 €
M031	34129	Lock ring crank shaft for BMW R24, R25, R25/2 and R25/3	0,46 €	0,55 €
M032	4064	Bearing crank shaft for BMW R24-R27 front end and /5 4-speed gearbox and for BMW R24-R69S input shaft front and output shaft rear	7,35 €	8,75 €
M033A	2064	Bearing crank shaft for BMW R24-R27, front and R24-R25/3, rear and crown wheel outer for BMW R25, R26 and R27	10,42 €	12,40 €
M033B	62060	Bearing crank shaft for BMW R24-R27 front, and R24-R25/3, rear reinforced, with nylon cage	45,88 €	54,60 €
M033C	3064	Bearing crank shaft for BMW R26 and R27, rear and R51/2-R69S and crownwheel for BMW R51/3-R68, outer	12,44 €	14,80 €
M033D	1085	Bearing crank shaft for BMW R26 and R27, rear and R51/2-R69S reinforced, with nylon cage, higher bearing play	45,80 €	54,50 €
M034	51440	Woodruff key crank shaft for BMW R24-R27, front and chainwheel R51/2 for inner oil pump wheel for wide key (= Article-No.: 58971)	1,51 €	1,80 €
M035	51454	Woodruff key generator rotor for BMW R24-R26	1,51 €	1,80 €
M036A	9026	Piston pin retainer - 18mm wire hoop, cross section: round	1,07 €	1,27 €
M036A	0019026	Piston pin retainer - 18mm lock hoop, cross section: squared	1,07 €	1,27 €
M036B	14202	Piston pin retainer - 20mm	1,05 €	1,25 €
M037A	90440	Conrod-Set for BMW R25, R25/2 and R25/3 with crank pin and roller cage	135,00 €	160,65 €
M037AA	1090440	Conrod for BMW R25, R25/2 and R25/3 for 300 conversion	90,00 €	107,10 €
M037B	90441	Conrod-Set for BMW R26 (narrow version) with crank pin and roller cage	135,00 €	160,65 €
M037BA	904508	Conrod-Set for BMW R26 (wide version) with crank pin and roller cage	135,00 €	160,65 €
M037C	90442	Conrod-Set for BMW R27 with crank pin and roller cage	135,00 €	160,65 €
M037DA	0090440	Conrod for BMW R25, R25/2 and R25/3	90,00 €	107,10 €
M037DB	0090441	Conrod for BMW R26	90,00 €	107,10 €
M037DB	0090443	Conrod for BMW R50, R50/2 and R50S	90,00 €	107,10 €
M037DC	0091442	Conrod for BMW R27	90,00 €	107,10 €
M038A	0012000	Piston for BMW R24, R25 and R25/2 - 68,00mm, complete with rings, pin and clips Tuning	100,84 €	120,00 €
M038A2B	12004	Piston for BMW R24-R25/3 - 68,00mm, Original KS/Nüral complete with rings, pin and clips, REMNANTS	134,45 €	160,00 €
M038A2C	0012008	Piston for BMW R24, R25 and R25/2 - 68,50mm, complete with rings, pin and clips Tuning	100,84 €	120,00 €
M038A3B	0012009	Piston for BMW R24, R25 and R25/2 - 69,00mm, complete with rings, pin and clips Tuning	100,84 €	120,00 €
M038A4C	0012010	Piston for BMW R24, R25 and R25/2 - 69,50mm, complete with rings, pin and clips Tuning	100,84 €	120,00 €
M038A5	0012011	Piston for BMW R24, R25 and R25/2 - 70,00mm, complete with rings, pin and clips Tuning	100,84 €	120,00 €
M038AA	912000	Piston for BMW R25/3 - 68,00mm, complete with rings, pin and clips Tuning	100,84 €	120,00 €
M038AB	912008	Piston for BMW R25/3 - 68,50mm, complete with rings, pin and clips Tuning	100,84 €	120,00 €
M038AC	912009	Piston for BMW R25/3 - 69,00mm, complete with rings, pin and clips Tuning	100,84 €	120,00 €
M038AD	912010	Piston for BMW R25/3 - 69,50mm, complete with rings, pin and clips Tuning	100,84 €	120,00 €
M038AE	912011	Piston for BMW R25/3 - 70,00mm, complete with rings, pin and clips Tuning	100,84 €	120,00 €
M038B1	0012110	Piston for BMW R26 - 68,00mm, complete with rings, pin and clips	100,84 €	120,00 €
M038B1a	12251	Piston for BMW R50S and R26 Tuning - 68,00mm (67,94mm) complete with rings, pin and clips	100,84 €	120,00 €
M038B2A	0012115	Piston for BMW R26 - 68,50mm, complete with rings, pin and clips	100,84 €	120,00 €
M038B2C	12254	Piston for BMW R50S and R26 Tuning - 68,50mm (67,44mm) complete with rings, pin and clips	100,84 €	120,00 €
M038B3	0012129	Piston for BMW R26 - 69,00mm, complete with rings, pin and clips	100,84 €	120,00 €
M038B3A	12257	Piston for BMW R50S and R26 Tuning - 69,00mm (68,94mm) complete with rings, pin and clips	100,84 €	120,00 €
M038B4A	0012133	Piston for BMW R26 - 69,50mm, complete with rings, pin and clips	100,84 €	120,00 €
M038B4C	922001	Piston for BMW R50S and R26 Tuning - 69,50mm (69,44mm) complete with rings, pin and clips	100,84 €	120,00 €
M038B5A	0012137	Piston for BMW R26 - 70,00mm, complete with rings, pin and clips	100,84 €	120,00 €
M038B5B	12116	Piston for BMW R26 - 70,00mm, complete with rings, pin and clips original, REMNANTS	134,45 €	160,00 €
M038B5C	922002	Piston für BMW R50S and R26 Tuning - 70,00mm (69,94mm) complete with rings, pin and clips	100,84 €	120,00 €
M038C1	910123	Piston für BMW R27 - 68,00mm, complete with rings, pin and clips	100,84 €	120,00 €
M038C2	910124	Piston for BMW R27 - 68,50mm, complete with rings, pin and clips	100,84 €	120,00 €
M038C3	910125	Piston for BMW R27 - 69,00mm, complete with rings, pin and clips	100,84 €	120,00 €
M038C4	910126	Piston for BMW R27 - 69,50mm, complete with rings, pin and clips	100,84 €	120,00 €



M038C5	910127	Piston for BMW R27 - 70,00mm, complete with rings, pin and clips	100,84 €	120,00 €
M038C6	1200300	Piston for BMW R26 und R27 - 72,00mm, complete with rings, pin and clips 300ccm	100,84 €	120,00 €
M039	999002	Lock ring for valve guide, 13mm for BMW R24-R67/3 and R50-R60/2	0,21 €	0,25 €
M040A	10108	Cylinder base gasket for BMW R24-R27, paper	2,10 €	2,50 €
M040B	1010801	Cylinder base gasket for BMW R24-27, aluminium, 0,5mm	4,54 €	5,40 €
M040C	1010802	Cylinder base gasket for BMW R24-27, aluminium, 1,0mm	4,75 €	5,65 €
M040D	1010803	Cylinder base gasket for BMW R24-27, aluminium, 1,5mm	4,87 €	5,80 €
M041A	10054	Cylinder head gasket for BMW R24-R25/3	4,33 €	5,15 €
M041A	0010054	Cylinder head gasket for BMW R24-R25/3 with silicone rings lapping torsional moment not under 50Nm!	4,87 €	5,80 €
M041B	9054	Cylinder head gasket for BMW R26, R27 and R51/3-R60/2	4,33 €	5,15 €
M041C	0022118	Cylinder head gasket for BMW R26, R27 and R51/3-R60/2 with silicone rings lapping torsional moment not under 50Nm!	4,87 €	5,80 €
M042	26824	Valve keeper for BMW R26, R27, R50/2 and R60/2, short cone	2,44 €	2,90 €
M042	26460	Valve keeper for BMW R24-R26, R51/2-R67/3, R50 and R60, long cone	2,44 €	2,90 €
M042	26502	Valve keeper for BMW R27, R50/2 and R60/2, double groove	2,65 €	3,15 €
M043	21806	Upper valve plate for BMW R24-R26, R51/2-R67/3, R50 and R60, long cone	7,44 €	8,85 €
M043	21807	Upper valve plate for BMW R27, R50/2 and R60/2, double groove	10,29 €	12,25 €
M043	2068	Upper valve plate for BMW R26, R27, R50/2 and R60/2, short cone	7,44 €	8,85 €
M044	26128	Lower valve plate for BMW R24-R67/3 and R50-R60/2	3,19 €	3,80 €
M045	100271	Valve guide 7mm inner / 13,10mm outer / 43mm long with lock ring	6,64 €	7,90 €
M045	100272	Valve guide 7mm inner / 13,15mm outer / 43mm long with lock ring	6,64 €	7,90 €
M045	100273	Valve guide 7mm inner / 13,20mm outer / 43mm long with lock ring	6,64 €	7,90 €
M045	100274	Valve guide 7mm inner / 13,25mm outer / 43mm long with lock ring	6,64 €	7,90 €
M045	100275	Valve guide 7mm inner / 13,30mm outer / 43mm long with lock ring	6,64 €	7,90 €
M045	100276	Valve guide 7mm inner / 13,35mm outer / 43mm long with lock ring	6,64 €	7,90 €
M045	10027	Valve guide 7mm inner / 13,06mm outer / 43mm long with lock ring	6,64 €	7,90 €
M045	1002775	Valve guide 7mm inner / 13,40mm outer / 43mm long with lock ring	9,66 €	11,50 €
M045	1002776	Valve guide 7mm inner / 13,50mm outer / 43mm long with lock ring	9,66 €	11,50 €
M045	1002722	Valve guide 7mm inner / 13,15mm outer / 49,8mm long with lock ring	6,81 €	8,10 €
M045	1002732	Valve guide 7mm inner / 13,20mm outer / 49,8mm long with lock ring	6,81 €	8,10 €
M045	1002742	Valve guide 7mm inner / 13,25mm outer / 49,8mm long with lock ring	6,81 €	8,10 €
M046	11018	Valve spring for BMW R24-R67/3 and R50-R60/2, inner	2,44 €	2,90 €
M047	21156	Valve cover nut for BMW R24-R27 and R51/2	3,32 €	3,95 €
M048	65031	Bracket for Valve cover for BMW R24-R27 and R51/2 used	10,08 €	12,00 €
M049	19054	Valve cover gasket for BMW R24-R67/3, R50/R60/2 and R50/5-R100	3,19 €	3,80 €
M050	10033	Valve cover-half for BMW R24-R27 used	18,49 €	22,00 €
M051	9018	Valve spring for BMW R24-R67/3 and R50-R60/2, outer	2,90 €	3,45 €
M051	10018	Valve spring set for BMW R24-R67/3 and R50-R60/2, (4 pieces)	10,25 €	12,20 €
M052A	0034140	Bushing, rocker arm for BMW R25/3-R27	7,14 €	8,50 €
M053	26109	Exhaust valve for BMW R24-R60/2, armored, long cone, 32mm	23,53 €	28,00 €
M053A	51472	Exhaust valve for BMW R24-R60/2, armored, double groove, 32mm	23,53 €	28,00 €
M053B	26107	Exhaust valve for BMW R24-R60/2, armored, short cone, 32mm	23,53 €	28,00 €
M053D	26170	Intake valve, double groove, 34mm	19,33 €	23,00 €
M053E	26101	Intake valve, short conus, 34mm	19,33 €	23,00 €
M053F	26501	Intake valve, long cone, 34mm	19,33 €	23,00 €
M054	21136	Screw for mounting cylinder head for BMW R25/2-R27, R51/3-R67/3 and R50-R60/2	7,44 €	8,85 €
M055B	21119	Distance washer rocker arm bracket for BMW R25-R69S	0,42 €	0,50 €
M056	34112	Thrust washer for rocker arm for BMW R24-R60/2	2,48 €	2,95 €
M057	03380	Stud bolt rocker cover for BMW R24, R25 and R51/2 M6x60	3,28 €	3,90 €
M057	03390	Stud bolt rocker cover for BMW R25/2, R25/3, R26 and R27 M8x75	2,94 €	3,50 €
M057	034130	Rocker arm shaft for BMW R25/3, R26 and R27	28,32 €	33,70 €
M057B	0034100	Rocker arm shaft for BMW R24, R25 and R51/2	22,27 €	26,50 €
M058	10105	Push rod tube for BMW R24, R25, R25/2 and R25/3 stainless steel	12,90 €	15,35 €
M058	10111	Push rod tube for BMW R26 and R27 stainless steel	12,90 €	15,35 €
M058	10110	Push rod tube for BMW R26 and R27 chromed	12,90 €	15,35 €
M059	104001	Cylinder head for BMW R25, R25/2, R26 and R27, OVERHAULT, naked WITHOUT valves	436,89 €	519,90 €
M059C	30030	Cylinder head rebuild-job for BMW R24-R60/2 new valve guides, springs, valves (dragged-in)	117,65 €	140,00 €
M060	10011	Cylinder for BMW R26 and R27, new	490,00 €	583,10 €
M060	1001101	Cylinder for BMW R26 and R27, bore 72mm, new for conversion to 300cc	490,00 €	583,10 €
M060A	10013	Cylinder bore and hone job - UP TO messure 70,00mm	69,33 €	82,50 €
M060A	1001313	Cylinder hone job	11,76 €	13,99 €
M060A	3003030	Cylinderhead planning job	16,81 €	20,00 €
M060B	10014	Cylinder sleeve replacing to 68,00mm Please send in your cylinder, including the number of your webshop-order. We resleeve your existing cylinder.	151,26 €	180,00 €



M060E	10004	Cylinder for BMW R25, R25/2 and R25/3, rebored	378,15 €	450,00 €
M061	37031	Bearing shield cam shaft for BMW R25-R27 used	9,20 €	10,95 €
M062	32100	Timing chain for BMW R24-R27	8,30 €	9,88 €
M063	38031	Chain wheel, camshaft for BMW R24-R27 used	14,71 €	17,50 €
M063A	38032	Chain wheel, camshaft for BMW R24-R26 Tuning	35,97 €	42,80 €
M063B	0032102	Chain wheel, camshaft for BMW R24-R27 new	26,01 €	30,95 €
M064A	53031	Engine breather spring for BMW R24, R25 and R26 used	1,43 €	1,70 €
M064B	54031	Engine breather spring for BMW R27	2,86 €	3,40 €
M065	52031	Engine breather screw for BMW R24, R25, R26 and R27 used	1,85 €	2,20 €
M066	33120	Push rod for BMW R24, R25, R25/2 and R25/3	22,98 €	27,35 €
M066	33122	Push rod for BMW R26 and R27	22,98 €	27,35 €
M067	0031000	Cam shaft for BMW R24-R26	205,88 €	245,00 €
M067B	31004	Cam shaft for BMW R27	229,75 €	273,40 €
M068	33501	Tappet guide for BMW R25/2, R25/3, R26 and R27, hexagon	30,17 €	35,90 €
M068	104031	Tappet guide for BMW R25, R25/2, R25/3, R26 and R27 used	13,20 €	15,71 €
M069	33016	Push rod rubber seal for BMW R25, R25/2, R25/3, R26 and R27	1,51 €	1,80 €
M069	0020811	Push rod rubber seal for BMW R24 and R25	2,35 €	2,80 €
M070	34126	Valve adjusting screw for BMW R25/2, R25/3, R26 and R27	7,14 €	8,50 €
M070	0034166	Valve adjusting screw for BMW R24, R25 and R51/2	12,94 €	15,40 €
M071	33127	Tappet for BMW R27, R50/2 and R60/2, standard convex typ	32,35 €	38,50 €
M071	33128	Tappet for BMW R27, R50/2 and R60/2, 1st oversize convex typ	32,35 €	38,50 €
M071	33129	Tappet for BMW R27, R50/2 and R60/2, 2nd oversize convex typ	32,35 €	38,50 €
M071AA	0033100	Tappet for BMW R24-R25/3, R26, R51/3, R50 and R60, standard flat type	32,35 €	38,50 €
M072	34128	Nut for valve adjusting screw	0,42 €	0,50 €
M073	30102	Inner lock washer for camshaft for BMW R24-R27, R51/3-R68 and R50-R69S used	1,93 €	2,30 €
M074	98170	Screw M 6 x 16, cylinder-head Allen® key, flat	0,25 €	0,30 €
M074A	30104	Mounting-screw for camshaft for BMW R24-R69S	0,25 €	0,30 €
M075	6203	Bearing cam shaft R24-R69S, crankshaft R51/3-R69S, front end, with 17mm cone wheel bearing R25-R25/2, pinion shaft R24, auxiliary shaft /5 4-gear box, crankshaft most front R51/3-R69	6,22 €	7,40 €
M076	51414	Woodruff key cam shaft for BMW R24-27 and R51/2 and oilpump for BMW R50/5-R90S until year of manufacture 1975	1,51 €	1,80 €
M077	43031	Engine breather for BMW R24-R26 used	18,49 €	22,00 €
M078	34002	Rocker arm for BMW R24-R60/2, complete used, please indicate which motorcycle type!!!	50,42 €	60,00 €
M080	52135	Gasket oil pump screen for BMW R24-R69S	0,97 €	1,15 €
M081	52120	Oil pump counter wheel for BMW R24-R27 used	12,78 €	15,21 €
M082	52112	Oil pump wheel for BMW R24-R27 used	12,78 €	15,21 €
M083A	52109	Oil pump cover for BMW R25/2 stainless steel	10,25 €	12,20 €
M083B	52111	Oil pump cover for BMW R25/3, R26 and R27 zincked	7,35 €	8,75 €
M083B	52110	Oil pump cover for BMW R25/3, R26 and R27 stainless steel	11,09 €	13,20 €
M087	52130	Lock plate oil pump / oil pan for BMW R24-R69S	1,68 €	2,00 €
M088	63420	Gasket ring oil dipstick also for oil pump cover for BMW R25/3-R27	0,50 €	0,60 €
M089	52116	Oil pump drive shaft for BMW R24-R26 used	16,72 €	19,90 €
M089a	0052116	Oil pump drive shaft for BMW R24-R26 NEW, original BMW, REMNANTS	69,66 €	82,90 €
M090	52106	Oilpump for BMW R24-R27, complete, WITHOUT oil pump screen used	62,94 €	74,90 €
M091	107031	Oil pump screen for BMW R24-R69S used	10,08 €	12,00 €
M092B	1056	Oil temperatur dipstick for BMW R24-R69S length: 235mm	37,77 €	44,95 €
M092C	09111	Oil dipstick for BMW R24-R27 polished	25,13 €	29,90 €
M093	70118	Fly wheel lock plate for BMW R24, R25, R25/2 and R25/3	2,77 €	3,30 €
M093	0016504	Fly wheel lock plate for BMW R26 and R27	2,77 €	3,30 €
M094A	70104	Thrust ring clutch for BMW R24, R25 and R25/2, rear	46,01 €	54,75 €
M094B	70100	Thrust ring clutch for BMW R25/3, R26 and R27, rear	52,10 €	62,00 €
M095	6103110	Clutch spring for BMW R26 and R27 and Isetta NEW	48,07 €	57,20 €
M095	6103103	Clutch spring for BMW R25/3 NEW	48,07 €	57,20 €
M096	98454	Spring washer B 6, DIN137 zincked	0,05 €	0,06 €
M097	98155	Screw for clutch 1-cylinder, also oilpump cover for BMW R60/6-R90S, M 6 x 16, hexagon	0,13 €	0,15 €
M098	68002	Fly wheel for BMW R24, R25, R25/2 and R25/3 used - Please indicate type!	159,66 €	190,00 €
M098	68022	Fly wheel for BMW R26 and R27 used	189,03 €	224,95 €
M098A	70108	Fly wheel bolt for BMW R25 and R25/2	13,36 €	15,90 €
M099	70500	Pressure plate clutch for BMW R26 and R27, front	69,03 €	82,15 €
M099A	70112	Pressure plate clutch for BMW R24, R25 and R25/2, front NEW – ORIGINAL BMW REMNANTS !!!	67,14 €	79,90 €
M099B	70010	Pressure plate clutch for BMW R25/3, front	68,91 €	82,00 €
M100A	6054	Clutch friction disc for BMW R24, R25 and R25/2	43,70 €	52,00 €
M100B	1054	Clutch friction disk for BMW R25/3, R26 and R27	43,70 €	52,00 €
M101	7018	Clutch spring for BMW R24, R25 and R25/2, Set (=3 pieces)	15,13 €	18,00 €
M102	99922	Chain tensioner set for BMW R24-R27 complete	12,02 €	14,30 €



M103	32110	Chain tensioner slide for BMW R24-R27	6,01 €	7,15 €
M103	99922	Chain tensioner set for BMW R24-R27 complete	12,02 €	14,30 €
M104	32535	Chain tensioner spring for BMW R24-R27	4,45 €	5,30 €
M104	99922	Chain tensioner set for BMW R24-R27 complete	12,02 €	14,30 €
M105	99922	Chain tensioner set for BMW R24-R27 complete	12,02 €	14,30 €
M105	99011	Screw for chain tensioner for BMW R24-R27	2,44 €	2,90 €
M106	98562	Stud bolt engine / gearbox for BMW R50-R69S, carburettor flange R25-R69S and fork /5, M8x25	3,32 €	3,95 €
M108A	16002	Crankshaft for BMW R24, R25, R25/2 and R25/3 IN EXCHANGE	208,40 €	248,00 €
M108AA	0016002	Crankshaft for BMW R24, R25, R25/2 and R25/3 NEW	281,22 €	334,65 €
M108B	16003	Crankshaft for BMW R26 IN EXCHANGE	208,40 €	248,00 €
M108BA	0016003	Crankshaft for BMW R26 NEW	281,22 €	334,65 €
M108BAA	1016003	Crankshaft for BMW R26, 72mm Hub NEW	381,22 €	453,65 €
M108BAAA	1016004	Crankshaft for BMW R26, 72mm Hub IN EXCHANGE	275,00 €	327,25 €
M108C	16020	Crankshaft for BMW R27 IN EXCHANGE	208,40 €	248,00 €
M108CA	0016020	Crankshaft for BMW R27 NEW	281,22 €	334,65 €
M108CAA	1016020	Crankshaft for BMW R27, 72mm Hub NEW	381,22 €	453,65 €
M108CAAA	1016021	Crankshaft for BMW R27, 72mm Hub IN EXCHANGE	275,00 €	327,25 €
M109	9903416	Stud bolt cylinder base for BMW R24-R27 and R51/3-R69S	5,00 €	5,95 €
M110	1068	Repair of exhaust thread (when a rest of your old thread still exists)	107,56 €	128,00 €
M111	00094	Spark-thread repair	118,07 €	140,50 €
M111	98501	Thread insert for short spark plug	4,16 €	4,95 €
M111	98502	Thread insert for long spark plug, for BMW R50/2, R60/2 and R69S	5,00 €	5,95 €
M112A	1017	Permanent lubricant VR500 Plastilube, 5.5 ml NO copper, lead or other heavy metal	1,51 €	1,80 €
M112B	46011	Copper paste, 100 gr	8,32 €	9,90 €
M113	03209	Stud bolt valve cover for BMW R51/3-R69S, timing cover R24-R69S gearbox cover R24-R69S and /5 4-gear, M6x25	1,51 €	1,80 €
M114A	024571	Sealing compound (Elastic gasket grease), 85ml	6,47 €	7,70 €
M114B	024570	Sealing compound (Elastic gasket grease), 40ml Hylomar M	4,96 €	5,90 €
M114C	024573	Sealing compound, Curil K, (gasket grease), 75ml	9,16 €	10,90 €
M115	98564	Stud bolt engine / gearbox for BMW R24-R27 M8x30	2,69 €	3,20 €
M116A	3064	Bearing crank shaft for BMW R26 and R27, rear and R51/2-R69S and crownwheel for BMW R51/3-R68, outer	12,44 €	14,80 €
M116B	1085	Bearing crank shaft for BMW R26 and R27, rear and R51/2-R69S reinforced, with nylon cage, higher bearing play	45,80 €	54,50 €
M116C	1086	Bearing crank shaft for BMW R26 and R27, rear and R51/2-R69S nylon cage	41,93 €	49,90 €
M116E	9008599	Bearing crank shaft for BMW R26 and R27, rear and R51/2-R69S with brass cage, reinforced	62,94 €	74,90 €



Group N: Engine housing, Cylinder, Piston all Twins

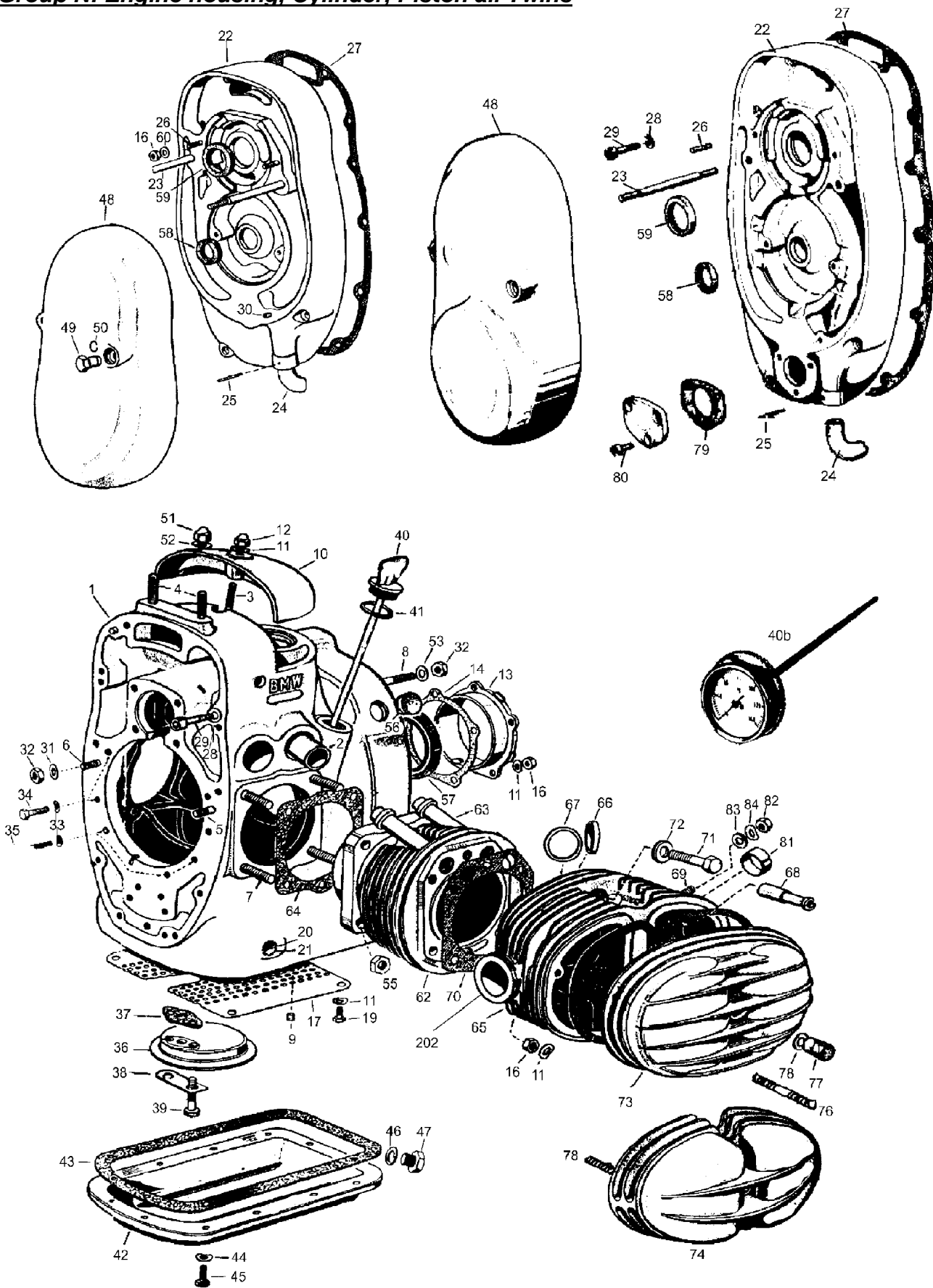

<u>Picture-No.</u>	<u>Article-No.</u>	<u>Description</u>	<u>Net</u>	<u>Gross</u>
N000	600016	Engine gasket set (no.M07), R68, R69, complete	56,26 €	66,95 €
N000A	600005	Engine gasket set (No.M06), for BMW R51/3-R67/3, complete	56,26 €	66,95 €
N000B	600006	Engine gasket set (No.M08) for BMW R50 and R60 "old", complete	56,26 €	66,95 €
N000C	600007	Engine gasket set (No.M09) for BMW R50/2, R50S, R60/2, complete	56,26 €	66,95 €
N000D	600010	Engine gasket set (No.M10), for BMW R69S, complete	56,26 €	66,95 €



N000E	600013	Engine gasket set (No.M05), for BMW R51/2, complete	58,74 €	69,90 €
N001	8036188	Grommet ignition timing for BMW R51/2, R68 and R69	10,50 €	12,50 €
N001A	01005	Engine housing for BMW R51/3-R60 "early" used	252,10 €	300,00 €
N001B	01031	Engine housing for BMW R50/2, R60/2, R69 and R69S used, price from	420,17 €	500,00 €
N003	98558	Stud bolt engine breather cover for BMW R51/3-R69S M6x60	3,53 €	4,20 €
N003	03209	Stud bolt valve cover for BMW R51/3-R69S, timing cover R24-R69S gearbox cover R24-R69S and /5 4-gear, M6x25	1,51 €	1,80 €
N004	98562	Stud bolt engine / gearbox for BMW R50-R69S, carburettor flange R25-R69S and fork /5, M8x25	3,32 €	3,95 €
N006	8890001	N006. This part is not available as new part. You can request is as used part!	9.999,99 €	9.999,99 €
N007	1241928	Stud bolt rear drive / swing arm for BMW R50/5-R100 and R45/R65 until year of manufacture 09/1980 and for cylinder base for BMW R51/3-R69S	2,10 €	2,50 €
N007	9903416	Stud bolt cylinder base for BMW R24-R27 and R51/3-R69S	5,00 €	5,95 €
N008	98566	Stud bolt engine / gearbox for BMW R51/2-R68 M8x35	3,28 €	3,90 €
N008	98562	Stud bolt engine / gearbox for BMW R50-R69S, carburettor flange R25-R69S and fork /5, M8x25	3,32 €	3,95 €
N010	106031	Cover for engine breather for BMW R51/3-R69S used	9,20 €	10,95 €
N011	98454	Spring washer B 6, DIN137 zincked	0,05 €	0,06 €
N012A	32070	Knurled nut breather cover for BMW R51/3-R68	2,56 €	3,05 €
N012B	99006	Cap nut M 6 stainless steel	0,84 €	1,00 €
N012B	0002193	Cap nut for engine breather cover for BMW R50-R69S Original REMNANTS!!!	2,48 €	2,95 €
N013	79001	Bearing shield crank shaft for BMW R50/2, R60/2, R69, R69S and R68, rear	82,35 €	98,00 €
N013A	01162	Bearing shield crank shaft for BMW R51/3, R50 "old", R60 "old" and R67, rear	70,00 €	83,30 €
N014	01164	Gasket bearing shield for BMW R51/3-R69S	1,43 €	1,70 €
N016	98323	Nut M 6 zincked	0,13 €	0,15 €
N017	01116	Screen plate engine for BMW R24-R69S used - please indicate typ!!!	7,39 €	8,79 €
N019	98156	Screw M 6 x 10, hexagon	0,13 €	0,15 €
N022A	7031	Timing cover for BMW R50/2, R60/2 and R69S used	168,07 €	200,00 €
N022B	6031	Timing cover for BMW R51/3-R67/3 and R50/R60 "early" used	109,24 €	130,00 €
N023A	01178	Stud bolt generator cover for BMW R51/3-R68 M6/M6, old version	8,36 €	9,95 €
N023B	01177	Stud bolt generator cover for BMW R51/3-R69S M8/M6	7,73 €	9,20 €
N024	02167	Engine breather pipe for BMW R51/3-R68, R50, R60 and R69 zincked, with angular end	10,76 €	12,80 €
N024A	02166	Engine breather pipe for BMW R50/2, R60/2 and R69S, short zincked, with straight end	10,76 €	12,80 €
N027	02164	Timing cover gasket for BMW R51/2	10,00 €	11,90 €
N027A	92172	Timing cover gasket for BMW R51/3-R69S	2,94 €	3,50 €
N028	98411	Washer M 6, DIN433 cincked	0,05 €	0,06 €
N029	98168	Screw M 6 x 40, cylinder-head Allen® key	0,25 €	0,30 €
N031	8890002	N031. This part is not available as new part. You can request is as used part!	9.999,99 €	9.999,99 €
N032	8890003	N032. This part is not available as new part. You can request is as used part!	9.999,99 €	9.999,99 €
N033	8890004	N033. This part is not available as new part. You can request is as used part!	9.999,99 €	9.999,99 €
N034	8890005	N034. This part is not available as new part. You can request is as used part!	9.999,99 €	9.999,99 €
N035	8890006	N035. This part is not available as new part. You can request is as used part!	9.999,99 €	9.999,99 €
N036	107031	Oil pump screen for BMW R24-R69S used	10,08 €	12,00 €
N037	52135	Gasket oil pump screen for BMW R24-R69S	0,97 €	1,15 €
N038	52130	Lock plate oil pump / oil pan for BMW R24-R69S	1,68 €	2,00 €
N039	98159	Screw M 6 x 30, hexagon with shaft	0,15 €	0,18 €
N040A	09126	Oil dipstick for BMW R51/3-R69S polished	28,74 €	34,20 €
N040B	09127	Oil dipstick for BMW R51/3-R69S used	15,13 €	18,00 €
N040B	1056	Oil temperatur dipstick for BMW R24-R69S length: 235mm	37,77 €	44,95 €
N041	63420	Gasket ring oil dipstick also for oil pump cover for BMW R25/3-R27	0,50 €	0,60 €
N042A	63031	Oil pan for BMW R51/3-R69S used	29,41 €	35,00 €
N042B	07029	Oil pan for BMW R51/3-R69S with distance piece for oil screen Capacity: ca. 2,5 liter, aluminium	83,11 €	98,90 €
N043A	07156	Oil pan gasket for BMW R51/3-R69S, Cork	3,99 €	4,75 €
N043A	0007156	Oil pan gasket for BMW R51/3-R69S, Paper	4,79 €	5,70 €
N043B	07150	Oil pan gasket for BMW R51/2, Cork	8,32 €	9,90 €
N044	98454	Spring washer B 6, DIN137 zincked	0,05 €	0,06 €
N045	98155	Screw for clutch 1-cylinder, also oilpump cover for BMW R60/6-R90S, M 6 x 16, hexagon	0,13 €	0,15 €
N046	2027	Gasket ring oil drain screw, M14x20x2	0,67 €	0,80 €
N047	07163	Oil drain screw for BMW R24-R69S, M14, magnetic zincked	3,19 €	3,80 €
N048	02187	Generator cover for BMW R50-R69S, 12V three-phase current	116,81 €	139,00 €
N048	117031	Generator cover for BMW R51/3-R69S, 6V used	243,70 €	290,00 €
N048	1002178	Generator cover for BMW R51/3-R68 and R50-R69S, 6 Volt	116,81 €	139,00 €
N048	1002179	Generator cover for BMW R51/3-R68 and R50-R69S, 6 Volt with revolution counter on cam shaft	159,66 €	190,00 €
N049	02191	Generator cover nut for BMW R51/3-R69S, hexagon with locking ring, wrench size 10	5,50 €	6,55 €



N049A	0001194	Generator cover nut for BMW R51/2-R68 until year of manufacture 1954, slotted	15,21 €	18,10 €
N050	07161	Lock ring for tool box screw for BMW R24-R25/2, R26, R27 and R51/2-R68	0,29 €	0,35 €
N051A	99008	Cap nut M 8 zincked	0,80 €	0,95 €
N051B	99007	Cap nut M 8 stainless steel	1,60 €	1,90 €
N055	98370	Cylinder base nut 6-point for BMW R24-R60S, wrench size 14mm, M10 stainless steel	2,35 €	2,80 €
N055	37789	Cylinder base 12-point nut for cardan coupling	2,31 €	2,75 €
N055	85002	Cylinder base nut 6-point for BMW R24-R60S, wrench size 14mm, M10 zincked	1,51 €	1,80 €
N056A	01106	Rubber plug for timing control hole, black for BMW R25-R69S and R50/5-R100	1,26 €	1,50 €
N056B	43016	Rubber plug for timing control hole, white for BMW R25-R69S and R50/5-R100	1,26 €	1,50 €
N057	99204	Repair-Set for flywheel seal-seat for BMW R26, R27 and R51/3-R69S	41,93 €	49,90 €
N057	01124	Radial seal ring, crankshaft rear for BMW R26, R27 and R51/3-R69S, silicon white, with spin	13,36 €	15,90 €
N057	16220	Radial seal ring, crankshaft rear for BMW R51/2	10,04 €	11,95 €
N057	01123	Radial seal ring, crankshaft rear for BMW R26, R27 and R51/3-R69S, silicone white	10,76 €	12,80 €
N057	01122	Radial seal ring, crankshaft rear for BMW R26, R27 and R51/3-R69S	8,82 €	10,50 €
N057	0112201	Radial seal ring, crankshaft rear for BMW R26, R27 and R51/3-R69S, "VITON" with spin	17,23 €	20,50 €
N057F	99196	Repair-Set for flywheel seal-seat for BMW R51/2 and pre-war BMWs	35,29 €	42,00 €
N058	02196	Radial seal ring, crankshaft front for BMW R51/3-R60 old and R68, R69 Kickstarter R24-R27, R50-R69S, / 5 + 5 speed gearbox	3,70 €	4,40 €
N058	02197	Radial seal ring, crankshaft front for BMW R50/2-R69S and kick starter for BMW R51/3-R68	3,70 €	4,40 €
N059	002190	Radial seal ring, camshaft for BMW R51/2 and pre-war	3,36 €	4,00 €
N059	56562	Radial seal ring, wheel and camshaft for BMW R51/3-R69S	3,91 €	4,65 €
N059	02199	Radial seal ring, camshaft for BMW R68 and R69	4,20 €	5,00 €
N062A	10031	Cylinder for BMW R60 and R60/2, used ASK FOR STOCK, please indicate size !!!	403,36 €	480,00 €
N062B	10013	Cylinder bore and hone job - UP TO messure 70,00mm	69,33 €	82,50 €
N062B	1001313	Cylinder hone job	11,76 €	13,99 €
N062B	3003030	Cylinderhead planning job	16,81 €	20,00 €
N062C	10012	Cylinder bore and hone job - OVER messure 70,00mm	85,00 €	101,15 €
N062D	10014	Cylinder sleeve replacing to 68,00mm Please send in your cylinder, including the number of your webshop-order. We resleeve your existing cylinder.	151,26 €	180,00 €
N062E	10015	Cylinder sleeve replacing to 72,00mm Please send in your cylinder, including the number of your webshop-order. We resleeve your existing cylinder.	161,34 €	191,99 €
N063	50213	Push rod tube for BMW R68, R69 and R69S stainless steel	13,36 €	15,90 €
N063	0050213	Push rod tube for BMW R60 and R60/2 stainless steel	13,36 €	15,90 €
N063	0101150	Push rod tube for BMW R51/2	20,97 €	24,95 €
N063	0010151	Push rod tube for BMW R51/3 stainless steel	20,97 €	24,95 €
N063	0010152	Push rod tube for BMW R67, R67/2 and R67/3 stainless steel	20,97 €	24,95 €
N063B	50215	Push rod tube for BMW R50, R50/2 and R50S stainless steel	13,36 €	15,90 €
N064A	10158	Cylinder base gasket for BMW R51/3-R69S, special seal paper	1,93 €	2,30 €
N064B	10161	Cylinder base gasket for BMW R50-R69S, aluminium, 0,5mm	2,52 €	3,00 €
N064C	10163	Cylinder base gasket for BMW R50-R69S, aluminium, 1,5mm	4,12 €	4,90 €
N064D	10154	Cylinder base gasket for BMW R51/2, paper	2,94 €	3,50 €
N065A	21042	Cylinder head for BMW R50-R60/2, OVERHAULT, nacked, left side	436,89 €	519,90 €
N065A	21041	Cylinder head for BMW R50-R60/2, OVERHAULT, nacked, right side	436,89 €	519,90 €
N065B	2104202	Cylinder head for BMW R50-R60/2, OVERHAULT, completely ready to install, left side	529,33 €	629,90 €
N065B	2104101	Cylinder head for BMW R50-R60/2, OVERHAULT, completely ready to install, right side	529,33 €	629,90 €
N065C2	021031	Cylinder head for BMW R69S, right side, new WITHOUT valves, REMNANTS	756,30 €	900,00 €
N065D	30030	Cylinder head rebuild-job for BMW R24-R60/2 new valve guides, springs, valves (dragged-in)	117,65 €	140,00 €
N065E	29030	Cylinder head rebuild-job for BMW R69S and R60/5-R80/7 Sent in ALL parts!	120,00 €	142,80 €
N066	00095	Valve seat ring replacing (ring and working time)	100,84 €	120,00 €
N066	54126	Valve seat ring Intake for BMW R25-27, R51/2-R67/3, R50S and for BMW R50-R60/2	14,87 €	17,70 €
N066	21122	Valve seat ring Intake for BMW R68, R69 and R69S	15,88 €	18,90 €
N067	21123	Valve seat ring Exhaust for BMW R68, R69 and R69S	16,72 €	19,90 €
N067	53700	Valve seat ring Exhaust for BMW R25, R25/3-R50S, R67-R67/3 and for R60, R60/2	16,72 €	19,90 €
N069	98562	Stud bolt engine / gearbox for BMW R50-R69S, carburettor flange R25-R69S and fork /5, M8x25	3,32 €	3,95 €
N070A	9054	Cylinder head gasket for BMW R26, R27 and R51/3-R60/2	4,33 €	5,15 €
N070AB	0022118	Cylinder head gasket for BMW R26, R27 and R51/3-R60/2 with silicone rings lapping torsional moment not under 50Nm!	4,87 €	5,80 €
N070B	21148	Cylinder head gasket for BMW R51/2	5,00 €	5,95 €
N070C	22168	Cylinder head gasket for BMW R68, R69 and R69S with silicone rings lapping torsional moment not under 50Nm!	4,87 €	5,80 €
N071	22108	Screw for mounting cylinder head for BMW R69S (short), M10 x 40 wrench size 14	5,46 €	6,50 €
N072	22166	Washer cylinder head screw for BMW R69 and R69S	3,07 €	3,65 €



N072	98501	Thread insert for short spark plug	4,16 €	4,95 €
N073	80030	Valve cover for BMW R51/3-R67/3 and R50-R60/2	54,20 €	64,50 €
N074	23027	Valve cover for BMW R68, R69 and R69S	83,82 €	99,75 €
N074	0023025	Valve cover for BMW R50S	116,72 €	138,90 €
N075	19054	Valve cover gasket for BMW R24-R67/3, R50/R60/2 and R50/5-R100	3,19 €	3,80 €
N075	18054	Valve cover gasket for BMW R68, R69 and R69S	4,03 €	4,80 €
N076	03380	Stud bolt rocker cover for BMW R24, R25 and R51/2 M6x60	3,28 €	3,90 €
N076A	08142	Stud bolt valve cover for BMW R68, R69, R69S and R50/5-R100 M8x50	3,19 €	3,80 €
N076B	08329	Stud bolt valve cover for BMW R51/3-R60/2 M8x40	4,12 €	4,90 €
N077	102001	Valve cover nut for BMW R51/3-R69S and R50/5-R100 chromed	3,32 €	3,95 €
N078	03209	Stud bolt valve cover for BMW R51/3-R69S, timing cover R24-R69S gearbox cover R24-R69S and /5 4-gear, M6x25	1,51 €	1,80 €
N079	02171	Gasket for revolution counter cover	2,10 €	2,50 €
N079f	8080155	Cover revolution counter drive for BMW R50-R69S	24,37 €	29,00 €
N080	98165	Screw M 6 x 16, cylinder-head Allen® key	0,17 €	0,20 €
N081	43168	Centering bushing carburettor for BMW R69S	4,12 €	4,90 €
N082	98352	Nut M 8 zinked	0,17 €	0,20 €
N083	98414	Washer M 8, DIN125, Form A cinced	0,06 €	0,07 €
N084	22082	Spring washer B 8, DIN137A zinked	0,08 €	0,10 €
N202	1068	Repair of exhaust thread (when a rest of your old thread still exists)	107,56 €	128,00 €
N203	90139	Wrench for finned exhaust nut forged steel, professional workshop quality	23,53 €	28,00 €
N204	00094	Spark-thread repair	118,07 €	140,50 €
N204A	46011	Copper paste, 100 gr	8,32 €	9,90 €
N204B	1017	Permanent lubricant VR500 Plastilube, 5.5 ml NO copper, lead or other heavy metal	1,51 €	1,80 €
N999	42161	Pin for revolution counter drive for BMW R50/2-R69S	0,29 €	0,35 €
N999	98180	Screw M 6 x 25, cylinder-head, slotted e.c. for wheel case cover BMW R51/2 (you need 9 screws)	0,29 €	0,35 €
N999	52169	Revolution counter gear on oilpump drive for BMW R50-R69S	42,86 €	51,00 €
N999	80159	Revolution counter drive for BMW R50-R69S for gear oil pump wheel	382,35 €	455,00 €
N999	9913470	Screw for bearing plate 1-cylinder and alternator cover BMW R51/2, M 6 x 18, hexagon	0,30 €	0,36 €



Group W: Inner engine parts all Twins

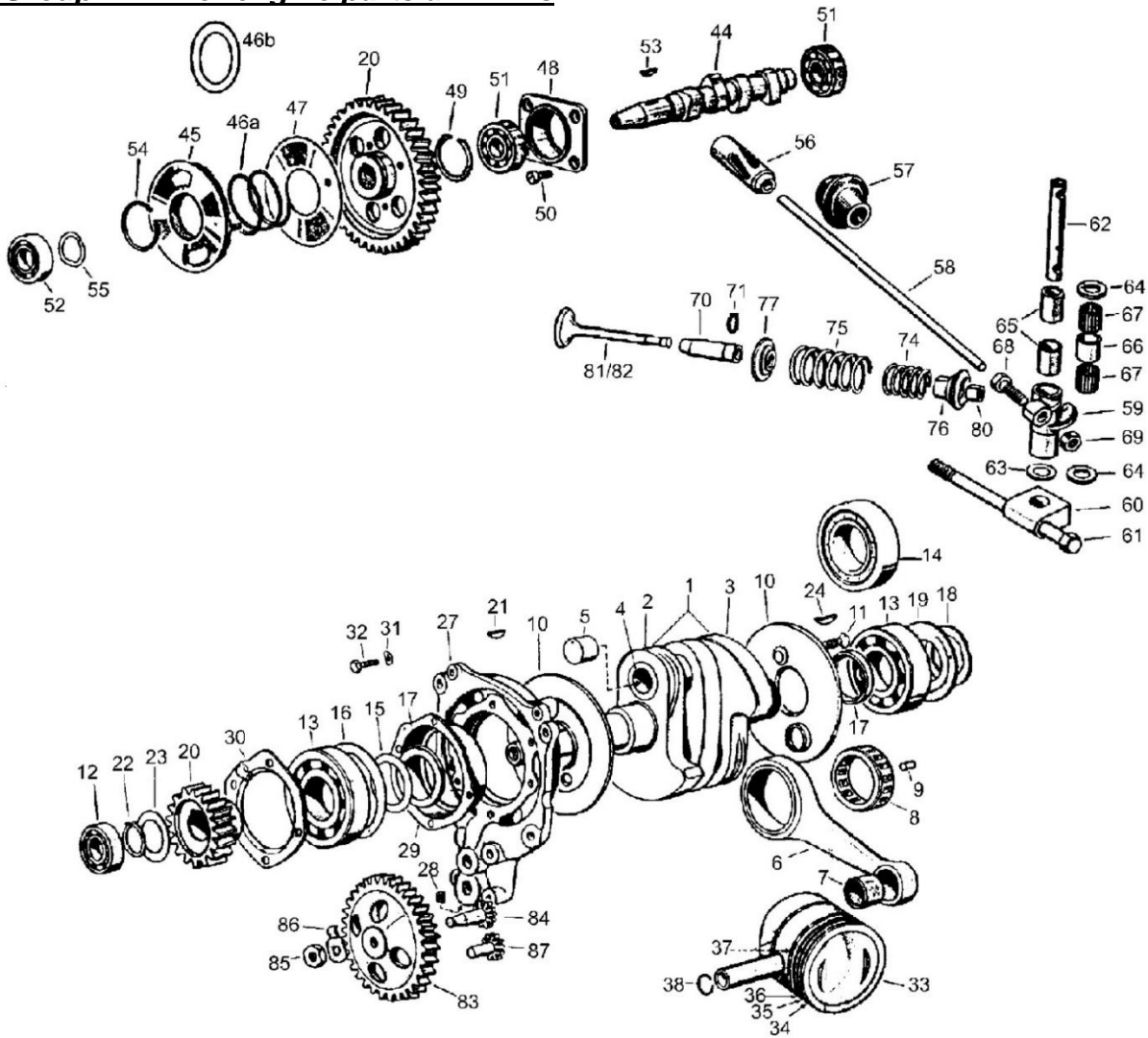

R51/2-R68

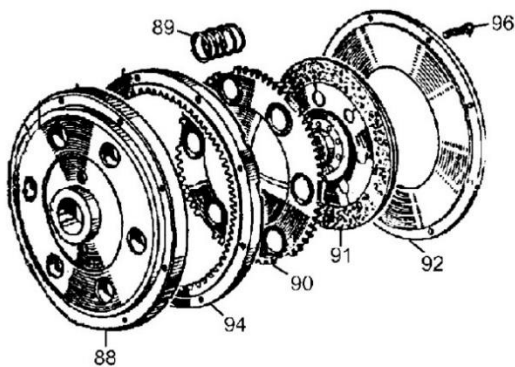

R50-69S

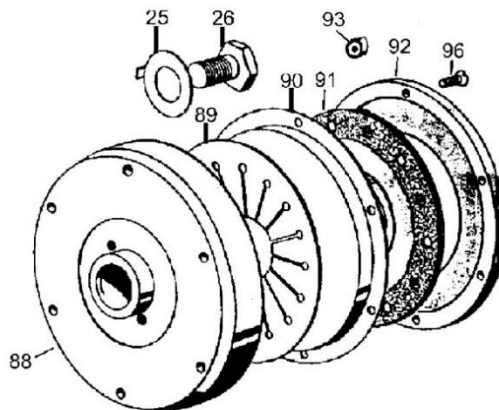

<u>Picture-No.</u>	<u>Article-No.</u>	<u>Description</u>	<u>Net</u>	<u>Gross</u>
W0002A	0016234	Crank pin for BMW R51/3 and R50 "old"	24,58 €	29,25 €
W0002B	0016262	Crank pin for BMW R50/2 and R50S	24,58 €	29,25 €
W0002C	02016246	Crank pin for BMW R50/2 and R50S, long	24,58 €	29,25 €
W0002D	0016233	Crank pin for BMW R67-R67/3 and R60 "old"	29,75 €	35,40 €
W0002E	0016231	Crank pin for BMW R68, R69 and R60/2, conical	29,75 €	35,40 €
W0002F	0016263	Crank pin for BMW R60/2 and R69S	29,75 €	35,40 €
W0002G	10016263	Crank pin for BMW R60/2 and R69S, long	29,75 €	35,40 €
W001	16039	Crankshaft for BMW R50 IN EXCHANGE	403,36 €	480,00 €



W001A	16060	Crankshaft for BMW R50/2 and R50S IN EXCHANGE	403,36 €	480,00 €
W001B	16027	Crankshaft for BMW R51/3 IN EXCHANGE	403,36 €	480,00 €
W001C	16045	Crankshaft for BMW R60 IN EXCHANGE	403,36 €	480,00 €
W001CA	0016045	Crankshaft for BMW R60 (old version) NEW	924,37 €	1.100,00 €
W001D	16062	Crankshaft for BMW R60/2, 125er Conrod IN EXCHANGE	403,36 €	480,00 €
W001DA	0016062	Crankshaft for BMW R60/2, 125er Conrod NEW	924,37 €	1.100,00 €
W001DAB	0016063	Crankshaft for BMW R60/2, 125er Conrod reinforced center, NEW	924,37 €	1.100,00 €
W001E	16031	Crankshaft for BMW R67, R67/2 and R67/3 IN EXCHANGE	403,36 €	480,00 €
W001EA	0016031	Crankshaft for BMW R67, R67/2 and R67/3 NEW	924,37 €	1.100,00 €
W001F	16035	Crankshaft for BMW R68 and R69 IN EXCHANGE	403,36 €	480,00 €
W001FA	0016036	Crankshaft for BMW R68 and R69 NEW	924,37 €	1.100,00 €
W001G	16066	Crankshaft for BMW R69S IN EXCHANGE	403,36 €	480,00 €
W001N	0016066	Crankshaft for BMW R69S NEW	924,37 €	1.100,00 €
W001NA	0016067	Crankshaft for BMW R69S reinforced center, NEW	924,37 €	1.100,00 €
W003	0016285	Crankweb for BMW R60/2, R68, R69 and R69S, rear NEW	319,33 €	380,00 €
W006AA	90443	Conrod-Set for BMW R51/2 with crank pin and roller cage	135,00 €	160,65 €
W006AB	90444	Conrod-Set for BMW R51/3 with crank pin and roller cage	135,00 €	160,65 €
W006B	90445	Conrod-Set for BMW R67, R67/2 and R67/3 with crank pin and roller cage	135,00 €	160,65 €
W006C	90446	Conrod-Set for BMW R50 "old" with crank pin and roller cage	135,00 €	160,65 €
W006D	90447	Conrod-Set for BMW R50/2 and R50S with crank pin and roller cage	135,00 €	160,65 €
W006D	9044701	Conrod-Set for BMW R50/2 and R50S (long) with crank pin and roller cage	135,00 €	160,65 €
W006E	90448	Conrod-Set for BMW R60/2 (125mm) with cylindric crank pin and roller cage	135,00 €	160,65 €
W006EA	90451	Conrod-Set for BMW R60/2 (125mm) with conic crank pin and roller cage	135,00 €	160,65 €
W006EE	9044800	Conrod-Set for BMW R60/2 (long for last model) with cylindric crank pin and roller cage	135,00 €	160,65 €
W006F	90449	Conrod-Set for BMW R60 "old" (130mm) with crank pin and roller cage	135,00 €	160,65 €
W006G	90450	Conrod-Set for BMW R69S with crank pin and roller cage	135,00 €	160,65 €
W006GA	904418	Conrod-Set for BMW R68 and R69 with crank pin and roller cage	135,00 €	160,65 €
W006GA	90452	Conrod-Set for BMW R69S (long for last model) with crank pin and roller cage	135,00 €	160,65 €
W006HA	0090441	Conrod for BMW R26	90,00 €	107,10 €
W006HA	0090443	Conrod for BMW R50, R50/2 and R50S	90,00 €	107,10 €
W006HB	0090442	Conrod for BMW R60/2	84,37 €	100,40 €
W006HC	0092441	Conrod for BMW R51/3	90,00 €	107,10 €
W006HD	0092442	Conrod for BMW R60, R68, R69 and R69S	84,37 €	100,40 €
W006HD	0092443	Conrod for BMW R51/2	84,37 €	100,40 €
W006HD	0092444	Conrod for BMW R67, R67/2 and R67/3	84,37 €	100,40 €
W007	3027	Piston pin bushing for BMW R26, R27, R68 and R50-R69S 20mm	7,39 €	8,80 €
W007A	4027	Piston pin bushing for BMW R24-R25/3 and R51/2-R67/3 18mm	7,39 €	8,80 €
W008A	17720	Roller cage for 5mm rollers, big version	28,12 €	33,46 €
W008B	16128	Roller cage for 7mm rollers for BMW R51/3-R69S used	28,12 €	33,46 €
W008C	0168124	Conrod bearing - 32x42x15,2 for BMW R24-R27, R51/2, R51/3, R50 and R50/2 silver-coated	30,25 €	36,00 €
W008D	168123	Conrod bearing - 32x42x15,2 for BMW R24-R27, R51/2, R51/3, R50 and R50/2 copper-coated	28,15 €	33,50 €
W009	168245	Conrod roller 5x10 +0,04 overmeasure	0,41 €	0,49 €
W009	168246	Conrod roller 5x10 +0,05 overmeasure	0,41 €	0,49 €
W009	168247	Conrod roller 7x10 +0,02 overmeasure	0,41 €	0,49 €
W009	168248	Conrod roller 7x10 +0,03 overmeasure	0,41 €	0,49 €
W009	168249	Conrod roller 7x10 +0,04 overmeasure	0,41 €	0,49 €
W009	168250	Conrod roller 7x10 +0,05 overmeasure	0,41 €	0,49 €
W009	168250	Conrod roller 7x10 +0,05 overmeasure	40,00 €	47,60 €
W009	168250	Conrod roller 7x10 +0,05 overmeasure	50,00 €	59,50 €
W009	168244	Conrod roller 5x10 +0,03 overmeasure	0,41 €	0,49 €
W009	16140	Conrod roller 7x10	0,41 €	0,49 €
W009	168243	Conrod roller 5x10 +0,02 overmeasure	0,41 €	0,49 €
W009	16824	Conrod roller 5x10	0,41 €	0,49 €
W009	168241	Conrod roller 5x10 +0,01 overmeasure	0,41 €	0,49 €
W009	168242	Conrod roller 7x10 +0,01 overmeasure	0,41 €	0,49 €
W010A	16216	Oil slinger for BMW R51/2, R51/3 and R50 "old"	12,52 €	14,90 €
W010B	16217	Oil slinger for BMW R67, R67/2, R67/3 and R60 "old"	12,52 €	14,90 €
W010C	16219	Oil slinger for BMW R50/2 and R50S	12,52 €	14,90 €
W010D	16221	Oil slinger for BMW R60/2 and R69S	12,52 €	14,90 €
W010DA	16218	Oil slinger for BMW R68 and R69	13,78 €	16,40 €
W011	00106	Screw for oil slinger for BMW R24-R69S	0,46 €	0,55 €
W012	6203	Bearing cam shaft R24-R69S, crankshaft R51/3-R69S, front end, with 17mm cone wheel bearing R25-R25/2, pinion shaft R24, auxiliary shaft /5 4-gear box, crankshaft most front R51/3-R69	6,22 €	7,40 €
W012A	7064	Bearing crank shaft for BMW R50/2, R60/2 and R69S, front end with 20mm cone	7,14 €	8,50 €



W013A	3064	Bearing crank shaft for BMW R26 and R27, rear and R51/2-R69S and crownwheel for BMW R51/3-R68, outer	12,44 €	14,80 €
W013B	1085	Bearing crank shaft for BMW R26 and R27, rear and R51/2-R69S reinforced, with nylon cage, higher bearing play	45,80 €	54,50 €
W013C	1086	Bearing crank shaft for BMW R26 and R27, rear and R51/2-R69S nylon cage	41,93 €	49,90 €
W013E	9008599	Bearing crank shaft for BMW R26 and R27, rear and R51/2-R69S with brass cage, reinforced	62,94 €	74,90 €
W014	1066	Spherical roller bearing crank shaft, rear for BMW R50S, R68, R69 and R69S with solid brass cage	159,58 €	189,90 €
W014	1065	Spherical roller bearing crank shaft, rear for BMW R50S, R68, R69 and R69S with plastic cage	136,89 €	162,90 €
W015A	16268	Spacer ring for crankshaft for BMW R50/2, R60/2 and R69S front	4,62 €	5,50 €
W015B	16240	Spacer ring crankshaft for BMW R51/3-R60 early front	3,32 €	3,95 €
W016	0016244	Distance washer crank shaft bearing for BMW R51/3-R67/3, front and R50/R60 "old" (not for /2 models), (crank shaft with 17mm Konus)	7,23 €	8,60 €
W017A	16212	Spacer ring for crankshaft for BMW R51/3-R67, R50/R60 old (4,2mm) front and rear	4,12 €	4,90 €
W017B	0016266	Spacer ring for crankshaft for BMW R50/2, R60/2 and R69S rear	3,78 €	4,50 €
W018	16130	Spring washer for crankshaft for BMW R26, R27 and R50-R69S, rear	2,27 €	2,70 €
W019	16252	Oil splash plate for crankshaft for BMW R51/3-R69S	4,58 €	5,45 €
W020	16389	Timing gear set for BMW R51/3-R69S, two gears with designation 0 only the newer gearing is available	323,40 €	384,85 €
W020	32129	Timing chain for BMW R51 and R51/2	58,74 €	69,90 €
W020	1638901	Timing gear set for BMW R51/3-R69S, two gears with designation -1 only the newer gearing is available	323,40 €	384,85 €
W020	1638902	Timing gear set for BMW R51/3-R69S, two gears with designation -2 only the newer gearing is available	323,40 €	384,85 €
W020	1638903	Timing gear set for BMW R51/3-R69S, two gears with designation -3 only the newer gearing is available	323,40 €	384,85 €
W020	1638904	Timing gear set for BMW R51/3-R69S, two gears with designation -4 only the newer gearing is available	323,40 €	384,85 €
W020	1638905	Timing gear set for BMW R51/3-R69S, two gears with designation -5 only the newer gearing is available	323,40 €	384,85 €
W020	1638906	Timing gear set for BMW R51/3-R69S, two gears with designation -6 only the newer gearing is available	323,40 €	384,85 €
W020	1638907	Timing gear set for BMW R51/3-R69S, two gears with designation -7 only the newer gearing is available	323,40 €	384,85 €
W020	1638908	Timing gear set for BMW R51/3-R69S, two gears with designation -8 only the newer gearing is available	323,40 €	384,85 €
W020	1638909	Timing gear set for BMW R51/3-R69S, two gears with designation -9 only the newer gearing is available	323,40 €	384,85 €
W020	1638910	Timing gear set for BMW R51/3-R69S, two gears with designation -10 only the newer gearing is available	323,40 €	384,85 €
W020	1638911	Timing gear set for BMW R51/3-R69S, two gears with designation +1 only the newer gearing is available	323,40 €	384,85 €
W020	1638912	Timing gear set for BMW R51/3-R69S, two gears with designation +2 only the newer gearing is available	323,40 €	384,85 €
W020	1638913	Timing gear set for BMW R51/3-R69S, two gears with designation +3 only the newer gearing is available	323,40 €	384,85 €
W020	1638914	Timing gear set for BMW R51/3-R69S, two gears with designation +4 only the newer gearing is available	323,40 €	384,85 €
W020	1638916	Timing gear set for BMW R51/3-R69S, two gears with designation +6 only the newer gearing is available	323,40 €	384,85 €
W020	1638917	Timing gear set for BMW R51/3-R69S, two gears with designation +7 only the newer gearing is available	323,40 €	384,85 €
W020	1638918	Timing gear set for BMW R51/3-R69S, two gears with designation +8 only the newer gearing is available	323,40 €	384,85 €
W020	1638919	Timing gear set for BMW R51/3-R69S, two gears with designation +9 only the newer gearing is available	323,40 €	384,85 €
W020	1638920	Timing gear set for BMW R51/3-R69S, two gears with designation +10 only the newer gearing is available	323,40 €	384,85 €
W021	51480	Woodruff key crank shaft R51/2-R100, front	1,51 €	1,80 €
W022	34171	Lock ring crank shaft for BMW R51/3-R68 and R50, R60 "old"	0,42 €	0,50 €
W024	16132	Woodruff key crank shaft for BMW R25/3-R69S, rear	2,10 €	2,50 €
W025	16224	Fly wheel lock plate for BMW R51/2, R51/3 and R67	2,77 €	3,30 €
W025a	0016225	Fly wheel lock plate for BMW R68 and R50-R69S	3,28 €	3,90 €
W026A	16228	Fly wheel screw for BMW R51/3-R67/3 wrench size 36mm	13,36 €	15,90 €
W026B	16251	Fly wheel screw for BMW R50-R69S and R68 wrench size 41mm	13,28 €	15,80 €
W027	109001	Bearing shield crank shaft for BMW R50/2, R60/2, R69 and R69S, front NEW	173,82 €	206,85 €
W027A	02029	Bearing shield crank shaft for BMW R51/3-R67/3, front used	143,10 €	170,29 €
W027B	02151	Bearing shield crank shaft for BMW R50 and R60 "old", front used	142,77 €	169,90 €
W029	02156	Bearing shield bushing crank shaft for BMW R51/3-R69S, front used	58,74 €	69,90 €
W030A	02176	Bearing shield cover for BMW R51/3-R67/3 and R50-R60 "old" used	30,68 €	36,51 €
W030B	02174	Bearing shield cover for BMW R50/2-R69S and R68 used	30,67 €	36,50 €
W032	9913499	Screw for bearing shield mounting for BMW R50-R69S, M 6 x 28	0,42 €	0,50 €
W033	9912250	Piston for BMW R50S - 68,00mm (67,93mm), complete with rings, pin and clips Original Nüral, REMNANTS	140,25 €	166,90 €



W033A1	12294	Piston for BMW R50 and R50/2 - 68,00mm, complete with rings, pin and clips	100,84 €	120,00 €
W033A2	12295	Piston for BMW R50 and R50/2 - 68,50mm, complete with rings, pin and clips	100,84 €	120,00 €
W033A4	12296	Piston for BMW R50 and R50/2 - 69,00mm, complete with rings, pin and clips	100,84 €	120,00 €
W033A6	12297	Piston for BMW R50 and R50/2 - 69,50mm, complete with rings, pin and clips	100,84 €	120,00 €
W033A6	2297695	Piston for BMW R50 and R50/2 - 69,50mm, complete with rings, pin and clips KS	134,45 €	160,00 €
W033A7	12298	Piston for BMW R50 and R50/2 - 70,00mm, complete with rings, pin and clips	100,84 €	120,00 €
W033A7	1229870	Piston for BMW R50 and R50/2 - 70,00mm, complete with rings, pin and clips original	134,45 €	160,00 €
W033A7	1229669	Piston for BMW R50 and R50/2 - 69,00mm, complete with rings, pin and clips original	144,20 €	171,60 €
W033B	12251	Piston for BMW R50S and R26 Tuning - 68,00mm (67,94mm) complete with rings, pin and clips	100,84 €	120,00 €
W033B1	12254	Piston for BMW R50S and R26 Tuning - 68,50mm (67,44mm) complete with rings, pin and clips	100,84 €	120,00 €
W033B2	12257	Piston for BMW R50S and R26 Tuning - 69,00mm (68,94mm) complete with rings, pin and clips	100,84 €	120,00 €
W033B3	922001	Piston for BMW R50S and R26 Tuning - 69,50mm (69,44mm) complete with rings, pin and clips	100,84 €	120,00 €
W033B4	922002	Piston für BMW R50S and R26 Tuning - 70,00mm (69,94mm) complete with rings, pin and clips	100,84 €	120,00 €
W033C1	12050	Piston for BMW R51/2 und R51/3 - 68,00mm, complete with rings, pin and clips	100,84 €	120,00 €
W033C2	12051	Piston for BMW R51/2 und R51/3 - 68,50mm, complete with rings, pin and clips	100,84 €	120,00 €
W033C3	12052	Piston for BMW R51/2 und R51/3 - 69,00mm, complete with rings, pin and clips	100,84 €	120,00 €
W033C4	12053	Piston for BMW R51/2 und R51/3 - 69,50mm, complete with rings, pin and clips	100,84 €	120,00 €
W033C5	12054	Piston for BMW R51/2 und R51/3 - 70,00mm, complete with rings, pin and clips	100,84 €	120,00 €
W033D1	012227	Piston for BMW R60 old - 72,00mm, complete with rings, pin and clips 130mm conrod	100,84 €	120,00 €
W033D2	012230	Piston for BMW R60 old - 72,50mm, complete with rings, pin and clips 130mm conrod	100,84 €	120,00 €
W033D3	012233	Piston for BMW R60 old - 73,00mm, complete with rings, pin and clips 130mm conrod	100,84 €	120,00 €
W033D4	012234	Piston for BMW R60 old - 73,50mm, complete with rings, pin and clips 130mm conrod	100,84 €	120,00 €
W033D5	012235	Piston for BMW R60 alt - 74,00mm, complete with rings, pin and clips 130mm conrod	100,84 €	120,00 €
W033D6	9122324	Piston for BMW R60 old - 72,00mm, complete with rings, pin and clips 130mm conrod, original, Remnants	126,05 €	150,00 €
W033D7	12232	Piston for BMW R60 old - 72,50mm, complete with rings, pin and clips 130mm conrod, original, Remnants	126,05 €	150,00 €
W033D8	9122323	Piston for BMW R60 old - 73,00mm, complete with rings, pin and clips 130mm conrod, original, Remnants	126,05 €	150,00 €
W033F4	912258	Piston for BMW R60/2 - 72,00mm, complete with rings, pin and clips 125mm conrod	100,84 €	120,00 €
W033F5	912259	Piston for BMW R60/2 - 72,50mm, complete with rings, pin and clips 125mm conrod	100,84 €	120,00 €
W033F5	912260	Piston for BMW R60/2 - 73,00mm, complete with rings, pin and clips 125mm conrod	100,84 €	120,00 €
W033F6	912261	Piston for BMW R60/2 - 73,50mm, complete with rings, pin and clips 125mm conrod	100,84 €	120,00 €
W033F7	912262	Piston for BMW R60/2 - 74,00mm, complete with rings, pin and clips 125mm conrod	100,84 €	120,00 €
W033G1	012070	Piston for BMW R67, R67/2 and R67/3 and R35 - 72,00mm complete with rings, pin and clips	100,84 €	120,00 €
W033G2	12078	Piston for BMW R67, R67/2 and R67/3 and R35 - 72,50mm complete with rings, pin and clips	100,84 €	120,00 €
W033G3	12079	Piston for BMW R67, R67/2 and R67/3 and R35 - 73,00mm complete with rings, pin and clips	100,84 €	120,00 €
W033G4	12080	Piston for BMW R67, R67/2 and R67/3 and R35 - 73,50mm complete with rings, pin and clips	100,84 €	120,00 €
W033G6	012081	Piston for BMW R67, R67/2 and R67/3 and R35 - 74,00mm complete with rings, pin and clips	100,84 €	120,00 €
W033G6a	12076	Piston for BMW R67, R67/2 and R67/3 - 75,50mm, complete with rings, pin and clips Remnants	100,84 €	120,00 €
W033G7	9999984	Piston for BMW R67, R67/2 and R67/3 - 72,50mm, complete with rings, pin and clips Original, Remnants	117,65 €	140,00 €
W033H0	12081	Piston for BMW R68 and R69 - 72,00mm, complete with rings, pin and clips	100,84 €	120,00 €
W033H1	12088	Piston for BMW R68 and R69 - 72,50mm, complete with rings, pin and clips	100,84 €	120,00 €
W033H2	12089	Piston for BMW R68 and R69 - 73,00mm, complete with rings, pin and clips	100,84 €	120,00 €
W033H3	12090	Piston for BMW R68 and R69 - 73,50mm, complete with rings, pin and clips	100,84 €	120,00 €
W033H4	12091	Piston for BMW R68 and R69 - 74,00mm, complete with rings, pin and clips	100,84 €	120,00 €
W033H5	9912089	Piston for BMW R68 and R69 - 73,00mm, complete with rings, pin and clips Original	163,78 €	194,90 €
W033H6	9912090	Piston for BMW R68 and R69 - 72,50mm, complete with rings, pin and clips Original	163,78 €	194,90 €
W033J1	912276	Piston for BMW R69S - 72,00mm, complete with rings, pin and clips	100,84 €	120,00 €
W033J2	912277	Piston for BMW R69S - 72,50mm, complete with rings, pin and clips	100,84 €	120,00 €
W033J2	9122772	Piston for BMW R69S - 72,50mm, complete with rings, pin and clips "KS"	163,78 €	194,90 €
W033J3	912278	Piston for BMW R69S - 73,00mm, complete with rings, pin and clips	100,84 €	120,00 €



W033J3	9122783	Piston for BMW R69S - 73,00mm, complete with rings, pin and clips Original	163,78 €	194,90 €
W033J4	912279	Piston for BMW R69S - 73,50mm, complete with rings, pin and clips	100,84 €	120,00 €
W033J4	9122794	Piston for BMW R69S - 73,50mm, complete with rings, pin and clips Original	163,78 €	194,90 €
W033J5	912280	Piston for BMW R69S - 74,00mm, complete with rings, pin and clips	100,84 €	120,00 €
W033J6	9122761	Piston for BMW R69S - 72,00mm, complete with rings, pin and clips Original	163,78 €	194,90 €
W034	1014547	Piston ring - 73,50mm, compression 1st ring, chrome plated, 1,75mm	7,80 €	9,28 €
W034A	14330	Piston ring set (3 pcs) - 68,00-70,00mm please indicate size!!!	24,20 €	28,80 €
W034B	14335	Piston ring set (3 pcs) - 72,00-74,00mm please indicate size!!!	24,20 €	28,80 €
W034C	1250327	Piston ring - 73,00mm, compression chrome plated, 2mm	7,23 €	8,60 €
W034E	1250328	Piston ring - 73,50mm, compression chrome plated, 2mm	7,23 €	8,60 €
W035*	1014546	Piston ring - 72,50mm, compression 1st ring, chrome plated	7,23 €	8,60 €
W035*	2014546	Piston ring - 72,50mm, compression 2nd ring	7,23 €	8,60 €
W035*	1256485	Piston ring - 72,00mm, compression 1st ring, chrome plated	7,23 €	8,60 €
W035*	2256485	Piston ring - 72,00mm, compression 2nd ring	7,23 €	8,60 €
W035A	14217	Piston ring - 68,00-70,50mm, compression define your needed oversize!!!	7,23 €	8,60 €
W035A	1142171	Piston ring - 69,00mm, compression 1st ring	7,23 €	8,60 €
W035A	1014217	Piston ring - 68,00mm, compression 1st ring, chrome plated	7,23 €	8,60 €
W035A	2014217	Piston ring - 68,00mm, compression 2nd ring	7,23 €	8,60 €
W035B	14546	Piston ring - 72,00-74,00mm, compression please indicate size!!!	7,23 €	8,60 €
W035C	2014213	Piston ring - 73,00mm, compression 2nd ring	7,23 €	8,60 €
W035D	2014214	Piston ring - 73,50mm, compression 2nd ring	7,23 €	8,60 €
W037A	14160	Piston ring - 68,00 - 70,50mm, oil scraper ring please indicate size!!!	10,25 €	12,20 €
W037B	14142	Piston ring - 72,00-74,00mm, oil scraper ring please indicate size!!!	10,25 €	12,20 €
W037C	3014546	Piston ring - 72,50mm, oil scraper ring 3rd ring	10,25 €	12,20 €
W037C	3256485	Piston ring - 72,00mm, oil scraper ring 3rd ring	10,25 €	12,20 €
W037D	3014216	Piston ring - 73,00mm, oil scraper ring 3rd ring	10,25 €	12,20 €
W037E	3014217	Piston ring - 73,50mm, oil scraper ring 3rd ring	10,25 €	12,20 €
W038	14203	Piston pin retainer - 20mm bolt	1,05 €	1,25 €
W038A	9026	Piston pin retainer - 18mm wire hoop, cross section: round	1,07 €	1,27 €
W038A	0019026	Piston pin retainer - 18mm lock hoop, cross section: squared	1,07 €	1,27 €
W038B	14202	Piston pin retainer - 20mm	1,05 €	1,25 €
W038C	40822	Piston pin - 18mm for BMW R24-R68	8,19 €	9,75 €
W038D	40823	Piston pin - 20 x 60mm	8,19 €	9,75 €
W038E	4082356	Piston pin - 20 x 56mm	8,19 €	9,75 €
W044A	31028	Cam shaft for BMW R51/3-R67/3 and R50-R60/2	148,28 €	176,45 €
W044B	31027	Cam shaft for BMW R51/3-R67/3 and R50-R60/2 used	76,69 €	91,26 €
W044C	31030	Cam shaft for BMW R50S and R69S	147,06 €	175,00 €
W044CA	97030	Cam shaft for BMW R50S and R69S, RO160.5, for racing bikes	198,32 €	236,00 €
W044CB	97031	Cam shaft for BMW R50S and R69S, RO113, for racing bikes	203,53 €	242,20 €
W044D	31025	Cam shaft for BMW R51/2, R51, R5, right side with oilpump drive	248,74 €	296,00 €
W044D	0031026	Cam shaft for BMW R51/2, R51, R5, left side	223,53 €	266,00 €
W044E	31029	Cam shaft for BMW R68 and R69	158,50 €	188,62 €
W044F	131029	Cam shaft for BMW R68 and R69, RO160, for racing bikes	252,94 €	301,00 €
W045A	47031	Engine breather for BMW R51/3-R68, R50, R60 und R69 with pin(s) used	67,23 €	80,00 €
W045B	31171	Engine breather for BMW R50/2, R60/2 and R69S with oval pins	100,76 €	119,90 €
W046A	31152	Engine breather spring for BMW R51/3-R69S	6,30 €	7,50 €
W046B	31707	Spring washer for engine breather for BMW R50S and R69S	1,93 €	2,30 €
W047	31164	Cover disk for engine breather for BMW R51/3-R67/3 and R50-R60/2	5,50 €	6,55 €
W048	108031	Bearing shield cam shaft for BMW R51/3-R69S used	12,77 €	15,20 €
W048A	0030150	Bearing shield cam shaft for BMW R51/3-R69S NEW	25,21 €	30,00 €
W049	30102	Inner lock washer for camshaft for BMW R24-R27, R51/3-R68 and R50-R69S used	1,93 €	2,30 €
W050	30104	Mounting-screw for camshaft for BMW R24-R69S	0,25 €	0,30 €
W051	6203	Bearing cam shaft R24-R69S, crankshaft R51/3-R69S, front end, with 17mm cone wheel bearing R25-R25/2, pinion shaft R24, auxiliary shaft /5 4-gear box, crankshaft most front R51/3-R69	6,22 €	7,40 €
W052	81041	Bearing cam shaft for BMW R68 and R69, front end	6,19 €	7,37 €
W053	51461	Woodruff key cam shaft for BMW R51/3-R69S and gearbox flange twins until year of manufacture 1969	1,51 €	1,80 €
W054	33451	Lock ring engine breather for BMW R51/3-R69S	1,68 €	2,00 €
W056	33158	Tappet for BMW R68, R69 and R69S, 1st oversize	32,56 €	38,75 €
W056	33157	Tappet for BMW R68, R69 and R69S, standard	32,56 €	38,75 €
W056	33127	Tappet for BMW R27, R50/2 and R60/2, standard convex typ	32,35 €	38,50 €
W056	33159	Tappet for BMW R68, R69 and R69S, 2nd oversize	32,56 €	38,75 €
W056	33128	Tappet for BMW R27, R50/2 and R60/2, 1st oversize convex typ	32,35 €	38,50 €
W056	33129	Tappet for BMW R27, R50/2 and R60/2, 2nd oversize convex typ	32,35 €	38,50 €
W056AA	0033100	Tappet for BMW R24-R25/3, R26, R51/3, R50 and R60, standard flat type	32,35 €	38,50 €
W057	40001	Push rod rubber seal for BMW R51/2	3,40 €	4,05 €
W057A	33163	Push rod rubber seal for BMW R51/3-R69S	3,78 €	4,50 €



W058	33172	Push rod for BMW R51/2	28,15 €	33,50 €
W058	33170	Push rod for BMW R51/3, R50, R50/2 and R50S	22,65 €	26,95 €
W058	33004	Push rod for BMW R68, R69 and R69S	41,93 €	49,90 €
W058B	33174	Push rod for BMW R60, R60/2 and R67-R67/3	22,98 €	27,35 €
W059	0034172	Rocker arm for BMW R68, R69 and R69S, without Valve adjusting screw and nut intake - left side, exhaust - right side	149,58 €	178,00 €
W059A	34002	Rocker arm for BMW R24-R60/2, complete used, please indicate which motorcycle type!!!	50,42 €	60,00 €
W059AA	0034174	Rocker arm for BMW R68, R69 and R69S, without Valve adjusting screw and nut intake - right side, exhaust - left side	149,58 €	178,00 €
W059B	34172	Rocker arm for BMW R68, R69 and R69S intake - left side, exhaust - right side	75,55 €	89,90 €
W059C	34174	Rocker arm for BMW R68, R69 and R69S intake - right side, exhaust - left side	75,55 €	89,90 €
W060A	34158	Rocker arm bracket for BMW R68, R69 and R69S	19,75 €	23,50 €
W060B	21119	Distance washer rocker arm bracket for BMW R25-R69S	0,42 €	0,50 €
W061	21136	Screw for mounting cylinder head for BMW R25/2-R27, R51/3-R67/3 and R50-R60/2	7,44 €	8,85 €
W061	22109	Screw for mounting cylinder head for BMW R69S (long), M10 x 155 wrench size 14	6,51 €	7,75 €
W062	0034100	Rocker arm shaft for BMW R24, R25 and R51/2	22,27 €	26,50 €
W062A	034150	Rocker arm shaft for BMW R51/3-R67/3 and R50-R60/2	16,39 €	19,50 €
W062B	34180	Rocker arm shaft for BMW R68, R69 and R69S	20,46 €	24,35 €
W063	34112	Thrust washer for rocker arm for BMW R24-R60/2	2,48 €	2,95 €
W064	34162	Thrust washer for rocker arm for BMW R68, R69 and R69S	2,52 €	3,00 €
W065	34145	Bushing, rocker arm for BMW R50-R60/2	9,41 €	11,20 €
W066	34186	Spacer bushing, rocker arm for BMW R68, R69 and R69S	4,54 €	5,40 €
W067	34190	Needle for rocker arm for BMW R68, R69 and R69S You need for 1 bike one set = 136 pieces	0,34 €	0,40 €
W068	34176	Valve adjusting screw for BMW R51/3-R67/3 and R50-R60/2	7,14 €	8,50 €
W068B	34178	Valve adjusting screw for BMW R68, R69, R69S and R50/5-R100	4,12 €	4,90 €
W069	34128	Nut for valve adjusting screw	0,42 €	0,50 €
W070	100271	Valve guide 7mm inner / 13,10mm outer / 43mm long with lock ring	6,64 €	7,90 €
W070	100274	Valve guide 7mm inner / 13,25mm outer / 43mm long with lock ring	6,64 €	7,90 €
W070	100275	Valve guide 7mm inner / 13,30mm outer / 43mm long with lock ring	6,64 €	7,90 €
W070	100276	Valve guide 7mm inner / 13,35mm outer / 43mm long with lock ring	6,64 €	7,90 €
W070	10027	Valve guide 7mm inner / 13,06mm outer / 43mm long with lock ring	6,64 €	7,90 €
W070	1002775	Valve guide 7mm inner / 13,40mm outer / 43mm long with lock ring	9,66 €	11,50 €
W070	1002776	Valve guide 7mm inner / 13,50mm outer / 43mm long with lock ring	9,66 €	11,50 €
W070	1002722	Valve guide 7mm inner / 13,15mm outer / 49,8mm long with lock ring	6,81 €	8,10 €
W070	1002732	Valve guide 7mm inner / 13,20mm outer / 49,8mm long with lock ring	6,81 €	8,10 €
W070	1002742	Valve guide 7mm inner / 13,25mm outer / 49,8mm long with lock ring	6,81 €	8,10 €
W070A	100272	Valve guide 7mm inner / 13,15mm outer / 43mm long with lock ring	6,64 €	7,90 €
W070A	100273	Valve guide 7mm inner / 13,20mm outer / 43mm long with lock ring	6,64 €	7,90 €
W070B	10029	Valve guide 8mm inner / 14,...mm outer (oversize) with lock ring, please indicate size!!!	6,81 €	8,10 €
W070B	1002926	Valve guide 8mm inner / 14,26mm outer (oversize) with lock ring	10,17 €	12,10 €
W070C	10028	Valve guide 8mm inner / 13,...mm outer with lock ring, please indicate size!!!	10,13 €	12,05 €
W071A	999002	Lock ring for valve guide, 13mm for BMW R24-R67/3 and R50-R60/2	0,21 €	0,25 €
W071B	999003	Lock ring for valve guide, 14mm	0,29 €	0,35 €
W072	98502	Threat insert for long spark plug, for BMW R50/2, R60/2 and R69S	5,00 €	5,95 €
W074	11018	Valve spring for BMW R24-R67/3 and R50-R60/2, inner	2,44 €	2,90 €
W075	13018	Valve spring for BMW R68, R69, R69S and R50/5-R100 new system	4,87 €	5,80 €
W075	9018	Valve spring for BMW R24-R67/3 and R50-R60/2, outer	2,90 €	3,45 €
W075	10018	Valve spring set for BMW R24-R67/3 and R50-R60/2, (4 pieces)	10,25 €	12,20 €
W075	12018	Valve spring set for BMW R68, R69, R69S and R50/5-R100 new system = 2 pieces	9,41 €	11,20 €
W076	21806	Upper valve plate for BMW R24-R26, R51/2-R67/3, R50 and R60, long cone	7,44 €	8,85 €
W076	21807	Upper valve plate for BMW R27, R50/2 and R60/2, double groove	10,29 €	12,25 €
W076	56554	Upper valve plate for BMW R50/5-R100 and R68, R69, R69S new system	4,20 €	5,00 €
W076	2068	Upper valve plate for BMW R26, R27, R50/2 and R60/2, short cone	7,44 €	8,85 €
W076	5655401	Upper valve plate for BMW R68-R69S old system for version with 2 springs	12,60 €	14,99 €
W076E	1026186	Grommet under valve plate for BMW R68, R69 and R69S old system	7,02 €	8,35 €
W077	26128	Lower valve plate for BMW R24-R67/3 and R50-R60/2	3,19 €	3,80 €
W077	50233	Lower valve plate for BMW R50/5-R100, R45/R65 and for BMW R68, R69 and R69S new system	3,28 €	3,90 €
W080	26824	Valve keeper for BMW R26, R27, R50/2 and R60/2, short cone	2,44 €	2,90 €
W080	26724	Valve keeper for BMW R68, R69, R69S and R50/5-R100, triple groove new system	1,47 €	1,75 €
W080	26460	Valve keeper for BMW R24-R26, R51/2-R67/3, R50 and R60, long cone	2,44 €	2,90 €
W080	26502	Valve keeper for BMW R27, R50/2 and R60/2, double groove	2,65 €	3,15 €
W081A	26170	Intake valve, double groove, 34mm	19,33 €	23,00 €



W081B	26101	Intake valve, short conus, 34mm	19,33 €	23,00 €
W081C	26501	Intake valve, long cone, 34mm	19,33 €	23,00 €
W081D	26151	Intake valve for BMW R68-R69S and R60/5-60/7, 38mm triple groove	29,75 €	35,40 €
W082A	51472	Exhaust valve for BMW R24-R60/2, armored, double groove, 32mm	23,53 €	28,00 €
W082B	26107	Exhaust valve for BMW R24-R60/2, armored, short cone, 32mm	23,53 €	28,00 €
W082D	26180	Exhaust valve for BMW R50S, armored, short cone	31,93 €	38,00 €
W082E	56679	Exhaust valve for BMW R68-R69S and R60/5/6/7, triple groove, 34mm	43,61 €	51,90 €
W083A	107001	Spur wheel oil pump for BMW R50/2, R60/2 and R69S, "sharp" angle, new style aluminium	109,16 €	129,90 €
W083B	52154	Spur wheel oil pump for BMW R51/3-R68, and R50, R60 old version, "small" angle aluminium	102,52 €	122,00 €
W084A	52166	Oil pump for BMW R51/3-R69S, complete (oil pump wheel, counter wheel, locking plate and screw nut)	66,47 €	79,10 €
W084B	52164	Oil pump wheel with left-hand thread for BMW R51/3-R69S	51,64 €	61,45 €
W085	52167	Nut left-hand thread for oil pump gear wheel	1,93 €	2,30 €
W086	52168	Lock plate oil pump for BMW R51/3-R69S, front	1,93 €	2,30 €
W087	52171	Oil pump counter wheel for BMW R51/3-R69S	17,94 €	21,35 €
W088D	68027	Fly wheel for BMW R51/3-R68 used	188,99 €	224,90 €
W089A	35030	Clutch spring for BMW R50, R50/2, R60, R60/2 and R69S	44,45 €	52,90 €
W089B	8018	Clutch spring for BMW R51/2-R68, Set (=6 pieces)	24,54 €	29,20 €
W090A	38001	Pressure plate clutch for BMW R50-R69S, front	75,21 €	89,50 €
W090B	70163	Pressure plate clutch for BMW R51/3-R68, dented	109,16 €	129,90 €
W091A	3054	Clutch friction disc for BMW R50-R69S	48,74 €	58,00 €
W091B	70025	Clutch friction disc for BMW R51/2-R68, 5mm (fits to thrust plate #70163)	48,74 €	58,00 €
W091BA	2054	Clutch friction disc for BMW R51/3-R68, 7mm	48,74 €	58,00 €
W092A	36030	Thrust ring clutch for BMW R50-R69S, rear	52,10 €	62,00 €
W092B	70151	Thrust ring clutch for BMW R51/3-R68, rear	95,80 €	114,00 €
W093	70511	Spacer washer clutch for BMW R50-R69S and R50/5-R75/5 only for pressure ring "without edge"	4,12 €	4,90 €
W094	070188	Gear ring clutch for BMW R51/3-R68 used	51,13 €	60,84 €
W096	31463	Screw for clutch for BMW R50/5-R100 until 09/1980, cylinder head-Allen® key	1,47 €	1,75 €
W096	00120	Screw for clutch for BMW R51/3-R68, M 6 x 30	0,46 €	0,55 €
W096	56001	Screw for clutch for BMW R51/2 and R50-R69S, M 8 x 1, slotted	0,97 €	1,15 €
W200A	024570	Sealing compound (Elastic gasket grease), 40ml Hylomar M	4,96 €	5,90 €
W200B	024571	Sealing compound (Elastic gasket grease), 85ml	6,47 €	7,70 €
W200C	024573	Sealing compound, Curil K, (gasket grease), 75ml	9,16 €	10,90 €
W220A	46011	Copper paste, 100 gr	8,32 €	9,90 €
W220B	1017	Permanent lubricant VR500 Plastilube, 5.5 ml NO copper, lead or other heavy metal	1,51 €	1,80 €
W74	0026160	Valve spring for BMW R69 and R69S, old version, inner	4,62 €	5,50 €
W75	0026164	Valve spring for BMW R69 and R69S, old version, outer	4,79 €	5,70 €



Group G: Gearbox all Singles

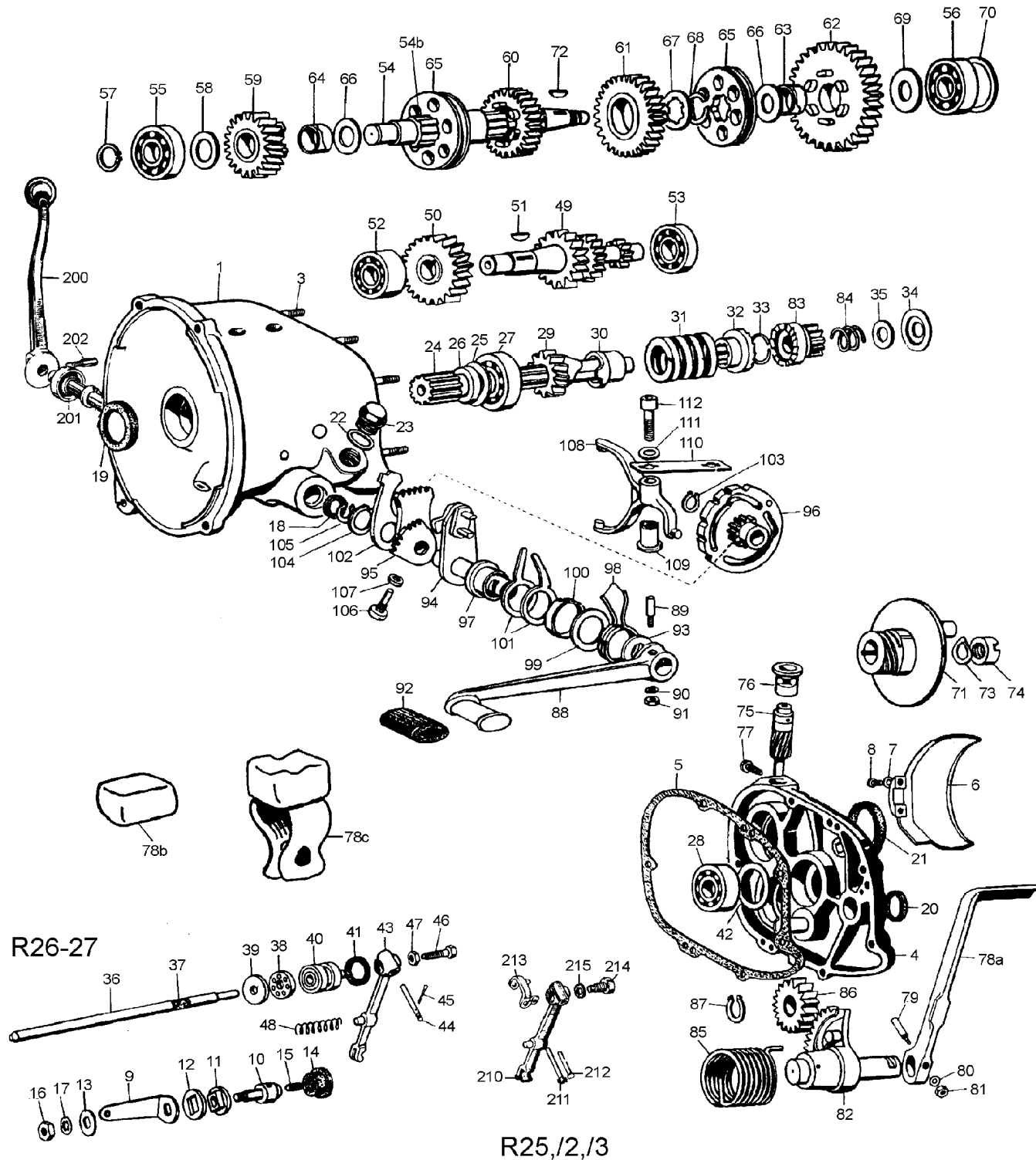

<u>Picture-No.</u>	<u>Article-No.</u>	<u>Description</u>	<u>Net</u>	<u>Gross</u>
G000	991140	Gearbox input repair kit for BMW R24-R27, R50-R69S and R50/5-R75/5 Speedy sleeve	37,95 €	45,16 €
G000	600018	Gasket set gearbox (No.G04), for BMW R26-R27	24,58 €	29,25 €
G000	600004	Gasket set gearbox (No.G03), for BMW R25/3	30,50 €	36,30 €
G000	600017	Gasket set gearbox (No.G02), for BMW R25 and R25/2	30,50 €	36,30 €
G000	06154	Idle indicator switch for BMW for BMW R50-R69S, complete NEW	28,78 €	34,25 €
G000	6000024	Gasket set gearbox (No.G01), for BMW R24	30,50 €	36,30 €
G001	06006	Gearbox for BMW R25 overhauled	920,17 €	1.095,00 €
G001AA	060061	Gearbox for BMW R25/2 overhauled	920,17 €	1.095,00 €
G001AB	060062	Gearbox for BMW R25/3 overhauled	920,17 €	1.095,00 €
G001B	06014	Gearbox for BMW R26 overhauled	920,17 €	1.095,00 €
G001C	06002	Gearbox for BMW R27 overhauled	920,17 €	1.095,00 €
G003	03209	Stud bolt valve cover for BMW R51/3-R69S, timing cover R24-R69S gearbox cover R24-R69S and /5 4-gear, M6x25	1,51 €	1,80 €



G004A	63213	Gear box cover for BMW R25, without idle tracking switch! new/old stock, original BMW, REMNANTS!!!	83,19 €	99,00 €
G004B	12012	Gear box cover for BMW R26 and R27 used	83,19 €	99,00 €
G005	06122	Gearbox cover gasket for BMW R24-R27	2,31 €	2,75 €
G006	12104	Protecting bell driving plate for BMW R26 and R27	35,29 €	42,00 €
G009	06152	Idle indicator switch spring for BMW R25/3, R26 and R27	6,64 €	7,90 €
G010	06158	Idle indicator switch contact bolt for BMW R25/2-R27 and R51/3-R69S	10,76 €	12,80 €
G014	06174	Rubber plug for idle connection for BMW R25/2-R69S	4,20 €	5,00 €
G015	05660	Idle indicator switch hexagon socket screw for BMW R25/2-R27 and R51/3-R69S	1,26 €	1,50 €
G016	98323	Nut M 6 zincked	0,13 €	0,15 €
G018	06124	Radial seal ring, foot shift lever for BMW R25-R27, R50-R69S and R50/5-R75/5	3,36 €	4,00 €
G018	1006118	Radial seal ring, foot shift lever for BMW R24	4,12 €	4,90 €
G019	10032	Radial seal ring, gearbox input for BMW R24-R27 and R50-R69S	4,33 €	5,15 €
G02	07163	Oil drain screw for BMW R24-R69S, M14, magnetic zincked	3,19 €	3,80 €
G02	0007163	Oil drain screw for BMW R24-R69S, M14, magnetic stainless steel	7,48 €	8,90 €
G020	02196	Radial seal ring, crankshaft front for BMW R51/3-R60 old and R68, R69 Kickstarter R24-R27, R50-R69S, / 5 + 5 speed gearbox	3,70 €	4,40 €
G021	11032	Radial seal ring, gearbox output for BMW R26, R27 and R50-R69S	6,09 €	7,25 €
G021	101030	Radial seal ring, gearbox output for BMW R24, R25, R25/2 and R25/3 as replacement for felt ring and cap	9,03 €	10,75 €
G021C	06110	Felt ring cap gearbox for BMW R25-R25/3 and R51/2	4,58 €	5,45 €
G021D	06114	Felt ring for gearbox for BMW R24, R25, R25/2, R25/3 and R51/2	3,19 €	3,80 €
G023	07104	Oil filler screw for BMW R24-R69S, M14 x 1,5 zincked	2,02 €	2,40 €
G023	0007104	Oil filler screw for BMW R24-R69S, M14 x 1,5 stainless steel, polished	5,97 €	7,10 €
G024	20009	Gearbox drive shaft for BMW R24, R25, R26 und R27 used	58,82 €	70,00 €
G026	00010	Race for seal ring drive shaft for BMW R25-R27 and R50-R69S	7,98 €	9,50 €
G027	4064	Bearing crank shaft for BMW R24-R27 front end and /5 4-speed gearbox and for BMW R24-R69S input shaft front and output shaft rear	7,35 €	8,75 €
G028	9064	Bearing gearbox input shaft for BMW R24-R27 and R50-R69S, rear	6,93 €	8,25 €
G029	20120	Starting damper (pinion) R25-R27, used	28,12 €	33,46 €
G030	20144	Damper for inlet shaft for BMW R24-R27 used	12,77 €	15,20 €
G030A	1020144	Damper for inlet shaft for BMW R24-R27 new	28,57 €	34,00 €
G033	20148	Lock ring input shaft for BMW R24-R27, R50-R69S and R50/5-R75/5	0,63 €	0,75 €
G034	20157	Bearing cover ring for BMW R24-R27 and R50-R69S	1,81 €	2,15 €
G035	20164	Thrust washer gearbox output shaft for BMW R24-R2, R50-R69S and R50/5-R75/5	4,03 €	4,80 €
G036A	20167	Clutch thrust rod for BMW R24, R25, R25/2 and R25/3	11,76 €	13,99 €
G036B	20168	Clutch thrust rod for BMW R26 and R27	11,76 €	13,99 €
G037	20132	Felt for clutch push rod for BMW R24-R27 and R50-R100 for mounting cut diagonally	2,48 €	2,95 €
G038	30961	Thrust bearing clutch ball bearing for BMW models until year of manufacture 09/1973	21,43 €	25,50 €
G039	30962	Thrust bearing, clutch for BMW R24-R26 and R51/2-R69S and BMW R50/5 until year of manufacture 09/1973	9,20 €	10,95 €
G040	20106	Clutch thrust piece for BMW R24, R25, R26 and R27	18,49 €	22,00 €
G041	20109	Sealing for clutch thrust piece	2,52 €	3,00 €
G044	20113	Bolt clutch release lever for BMW R26-R69S, 0,5mm oversize stainless steel	6,72 €	8,00 €
G044	20112	Bolt clutch release lever for BMW R26-R69S stainless steel	4,62 €	5,50 €
G045	945180	Split pin for release lever for BMW R26, R27 and R50-R69S and for bolt side stand R50-R69S	0,17 €	0,20 €
G046	30108	Adjusting screw for clutch release lever for BMW R26-R27, R50-69S, R50/5 until year of manufacture 09/1980, M8	2,94 €	3,50 €
G047	21104	Nut M 8 , flat zincked	0,21 €	0,25 €
G048	80122	Clutch lever spring until year of manufacture 08/1973	1,64 €	1,95 €
G049	1040027	Intermediate gear box shaft for BMW R27 and R50 old version	197,48 €	235,00 €
G050	30153	Gear-wheel 4th gear outputshaft for BMW R26-R69S	134,03 €	159,50 €
G050a	1030154	Gear-wheel 3rd gear outputshaft for BMW R26-R69S	134,03 €	159,50 €
G051	5148003	Woodruff key gearbox for BMW R24-R27 and R51/3-R69S Intermediate shaft R24-R69S, output shaft R51/3-R68	1,51 €	1,80 €
G052	15064	Bearing auxiliary shaft for BMW R24-R27 and R50-R69S, front front/rear wheel R25-R25/3	22,65 €	26,95 €
G052a	9981910	Bearing auxiliary shaft for BMW R24, front and rear	22,48 €	26,75 €
G053	6203	Bearing cam shaft R24-R69S, crankshaft R51/3-R69S, front end, with 17mm cone wheel bearing R25-R25/2, pinion shaft R24, auxiliary shaft /5 4-gear box, crankshaft most front R51/3-R69	6,22 €	7,40 €
G053a	9981910	Bearing auxiliary shaft for BMW R24, front and rear	22,48 €	26,75 €
G054	81416	Gearbox output shaft for BMW R24-R27 used	71,85 €	85,50 €
G054B	30262	Bushing for BMW R25-R69S, 2nd and 3rd gear	30,17 €	35,90 €
G055	8064	Bearing output shaft for BMW R24-R27 and R50-R69S, front and for front wheel BMW R24	7,48 €	8,90 €
G056	4064	Bearing crank shaft for BMW R24-R27 front end and /5 4-speed gearbox and for BMW R24-R69S input shaft front and output shaft rear	7,35 €	8,75 €
G057	34090	Lock ring output shaft for BMW R24-R69S, front	0,25 €	0,30 €



G059	40108	Gear-wheel 4th gear auxiliary shaft for BMW R26-R69S	50,00 €	59,50 €
G059	30151	Spur wheel 4th gear for BMW R26, R27 and R50-R69S	136,05 €	161,90 €
G062	1030132	Spur wheel 1st gear for BMW R24, R25, R25/2 and R25/3	89,92 €	107,00 €
G063	30259	Bushing for BMW R25-R69S, 1st gear-wheel	15,13 €	18,00 €
G064	30266	Bushing for BMW R25-R69S, 4th gear-wheel	12,77 €	15,20 €
G065	11016	Sliding claw for BMW R24-R27 and R50-R69S	35,29 €	42,00 €
G066	40104	Thrust washer gearbox output shaft for BMW R25-R69S 1st and 4th gear wheel	4,33 €	5,15 €
G070	1231651	Distance washer for outlet shaft for BMW R24-R69S, 0,20mm	2,69 €	3,20 €
G070	1231652	Distance washer for outlet shaft for BMW R24-R69S, 0,30mm	2,69 €	3,20 €
G070	1231653	Distance washer for outlet shaft for BMW R24-R69S, 0,38mm	2,69 €	3,20 €
G070	1231654	Distance washer for outlet shaft for BMW R24-R69S, 0,50mm	2,69 €	3,20 €
G070	1231655	Distance washer for outlet shaft for BMW R24-R69S, 0,60mm	2,69 €	3,20 €
G070	1231656	Distance washer for outlet shaft for BMW R24-R69S, 0,75mm	2,69 €	3,20 €
G070	1231657	Distance washer for outlet shaft for BMW R24-R69S, 0,88mm	2,69 €	3,20 €
G070	2231657	Distance washer gearbox outlet shaft for BMW R24-R60S, 0,95mm and wheel bearing for BMW R51/3-R68	2,69 €	3,20 €
G070	1231658	Distance washer for outlet shaft for BMW R24-R69S, 1,00mm	2,69 €	3,20 €
G071	30172	Gearbox flange for BMW R25, R26 and R27	117,56 €	139,90 €
G072	51461	Woodruff key cam shaft for BMW R51/3-R69S and gearbox flange twins until year of manufacture 1969	1,51 €	1,80 €
G073	30170	Washer M14, DIN988 S for castle nut gearbox flange for BMW R24-R27	0,42 €	0,50 €
G074	30120	Castle nut gearbox flange M14 for BMW R24-R27 and R51/2-R68 and for BMW R50-R69S (old version) gearbox flange	8,36 €	9,95 €
G075A	30058	Speedo drive for BMW R24-R27 and R50-R69S	41,68 €	49,60 €
G075B	111031	Speedo drive for BMW R24-R27, R50-R69S and /5 used	33,61 €	40,00 €
G076A	30128	Bushing speedo-cable for BMW R25-R25/3 and R51/3-R68 fat end	8,32 €	9,90 €
G076B	30176	Bushing speedo-cable for BMW R26-R69S and R50/5-R100 thin end	3,19 €	3,80 €
G077	30174	Speedo cable holding screw with breather hole for BMW R24-R69S stainless steel	5,80 €	6,90 €
G077A	31065	Speedo cable screw with breather hole for BMW R24-R69S zincked	2,35 €	2,80 €
G078	28135	Center stand stopper for BMW R25-R69S and swing arm bumper and kickstarter stopper for BMW R27	2,35 €	2,80 €
G078A	25116	Kick starter bumper for BMW R24-R26	7,35 €	8,75 €
G078A	56120	Kick starter for BMW R25-R27 and R50-R69S, straight model Aluminum	94,83 €	112,85 €
G078B	25116	Kick starter bumper for BMW R24-R26	7,35 €	8,75 €
G078C	25116	Kick starter bumper for BMW R24-R26	7,35 €	8,75 €
G078D	25116	Kick starter bumper for BMW R24-R26	7,35 €	8,75 €
G078e	34156	Kick starter bumper mounting set for BMW R24-R69S	4,16 €	4,95 €
G079	50016	Mounting bolt for kick starter for BMW R24-R27, R50-R69S and R50/5-R100 zincked	4,16 €	4,95 €
G079A	56124	Mounting bolt for kick starter for BMW R24-R27, R50-R69S and R50/5-R100 stainless steel	5,88 €	7,00 €
G081	98352	Nut M 8 zincked	0,17 €	0,20 €
G081	0098352	Nut M 8, wrench size 14 zincked	1,01 €	1,20 €
G082	1056102	Kick starter section gear for BMW R25-R27 used	85,00 €	101,15 €
G083	56104	Kick starter gear wheel, drive shaft for BMW R25-R27 and R50-R69S used	28,12 €	33,46 €
G083a	1056104	Kick starter gear wheel, drive shaft for BMW R25-R27 and R50-R69S new	57,73 €	68,70 €
G084	56116	Spring for input shaft for BMW R25-R27, R50-R69S and R50/5-R75/5	4,20 €	5,00 €
G085	56112	Kick starter spring for BMW R24-R27, R50-R69S and R50/5-R75/5	5,71 €	6,79 €
G086	56108	Kick starter intermediate gear for BMW R24-R27, R50-R69S and R50/5-R75/5	75,55 €	89,90 €
G087	34080	Lock ring kickstarter gear for BMW R24-R27, R50-R69S and R50/5-R75/5R69S	0,25 €	0,30 €
G088	66107	Foot shift lever for BMW R25, R26 and R27 used	25,13 €	29,90 €
G089	66103	Wedge for shift pedal for BMW R24-R69S stainless steel	6,51 €	7,75 €
G089	66102	Wedge for shift pedal for BMW R24-R69S zincked	3,82 €	4,55 €
G091	98326	Nut M 6, self-locking zincked	0,17 €	0,20 €
G092	45016	Shift lever rubber for BMW R24-R69S and R50/5-R75/5	1,51 €	1,80 €
G093	30812	Shift lever shim for BMW R25/2-R69S and R50/5-R75/5, 0,75mm	1,26 €	1,50 €
G093	30813	Shift lever shim for BMW R25/2-R69S and R50/5-R75/5, 0,50mm	1,26 €	1,50 €
G093	30811	Shift lever shim for BMW R25/2-R69S and R50/5-R75/5, 1,00mm	1,26 €	1,50 €
G098	66150	Shift lever return spring for BMW R24-R27 and R50-R69S	5,80 €	6,90 €
G100	66146	Lock washer for shifter for BMW R24-R27 and R50-R69S	7,14 €	8,50 €
G103	34060	Lock ring switch wafer for BMW R24-R69S and breather cam shaft for BMW R27	0,21 €	0,25 €
G104	34120	Lock ring shifting shaft for BMW R24-R69S, big	0,34 €	0,40 €
G105	34071	Lock ring shifting shaft for BMW R24-R69S, small	0,21 €	0,25 €
G108A	66206	Shifter fork for BMW R24-R27 and R50-R69S	79,83 €	95,00 €
G109	1230086	Excenter bushing shifter fork for BMW R24-R90S	24,87 €	29,60 €
G112	19736	Screw for shifter fork for BMW R26 and R27 Allen® head	2,02 €	2,40 €
G112	66182	Screw for shifter fork for BMW R25, R25/2 and R25/3 slotted	8,62 €	10,26 €
G200	66118	Hand shift lever for BMW R25 and R25/2 used	14,20 €	16,90 €
G201	06150	Radial seal ring, hand shift lever for BMW R24, R25 and R25/2	3,36 €	4,00 €



G202A	66122	Wedge for hand lever for BMW R24-R25/2 and R51/2-R68 zincd	4,20 €	5,00 €
G202B	190017	Wedge for hand lever for BMW R24-R25/2 and R51/2-R68 stainless steel	5,88 €	7,00 €
G210	80104	Clutch release lever for BMW R25-R27 used	16,72 €	19,90 €
G211	80134	Bolt clutch-release lever carrier for BMW R25-R25/3	4,75 €	5,65 €
G212	80108	Bolt clutch release lever for BMW R25-R25/3	4,75 €	5,65 €
G212	45055	Split pin for clutch lever for BMW R25, R25/2 and R25/3	0,08 €	0,10 €
G213	20124	Bracket for clutch release lever for BMW R25, R25/2 and R25/3	12,02 €	14,30 €
G214	80113	Adjusting screw for clutch release lever for BMW R25-R25/3, M8 stanless steel	3,28 €	3,90 €
G214A	98327	Nut M 8, flat stainless steel	0,28 €	0,33 €
G215	21104	Nut M 8 , flat zincked	0,21 €	0,25 €



Group H: Gearbox all Twins 1955-1969

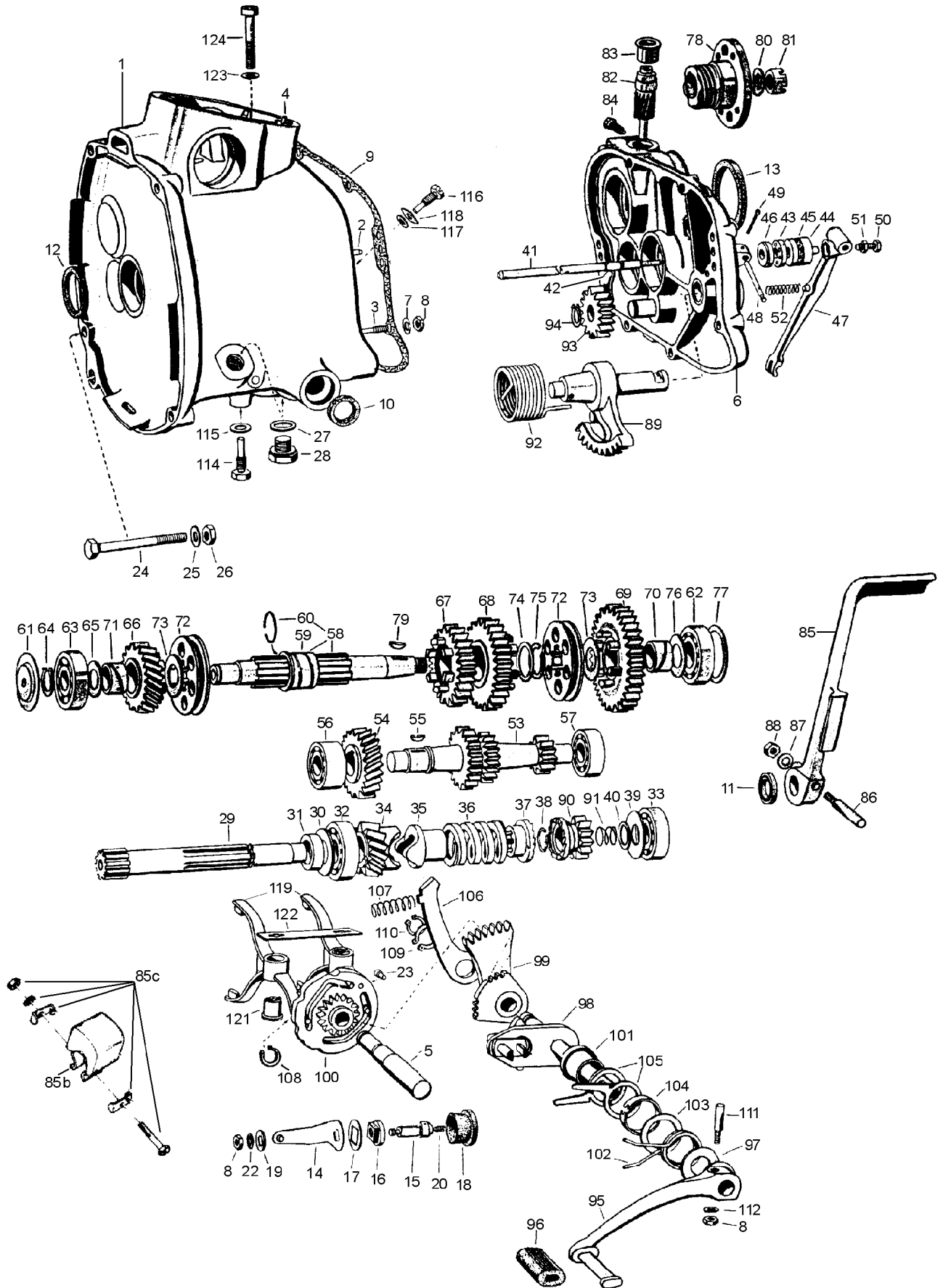

<u>Picture-No.</u>	<u>Article-No.</u>	<u>Description</u>	<u>Net</u>	<u>Gross</u>
H000	991140	Gearbox input repair kit for BMW R24-R27, R50-R69S and R50/5-R75/5 Speedy sleeve	37,95 €	45,16 €
H000	600011	Gasket set gearbox (No.G06), for BMW R50-R69S	24,58 €	29,25 €
H000	06154	Idle indicator switch for BMW for BMW R50-R69S, complete NEW	28,78 €	34,25 €
H001	06029	Gearbox for BMW R50-R69S overhauled	1.134,45 €	1.350,00 €



H001B	006029	Gearbox housing for BMW R50-R69S used	215,52 €	256,47 €
H003	03209	Stud bolt valve cover for BMW R51/3-R69S, timing cover R24-R69S gearbox cover R24-R69S and /5 4-gear, M6x25	1,51 €	1,80 €
H005	06142	Bolt for labyrinth (Gearbox) for BMW R50-R69S	2,81 €	3,34 €
H006	12031	Gearbox cover for BMW R50-R69S new/old stock, original BMW, REMNANTS!!!	218,49 €	260,00 €
H008	98323	Nut M 6 zincked	0,13 €	0,15 €
H009	06280	Gearbox cover gasket for 4-speed-transmission, 2-cylinders, years of manufacture 1955-1973	2,31 €	2,75 €
H010	06124	Radial seal ring, foot shift lever for BMW R25-R27, R50-R69S and R50/5-R75/5	3,36 €	4,00 €
H011	02196	Radial seal ring, crankshaft front for BMW R51/3-R60 old and R68, R69 Kickstarter R24-R27, R50-R69S, / 5 + 5 speed gearbox	3,70 €	4,40 €
H012	10032	Radial seal ring, gearbox input for BMW R24-R27 and R50-R69S	4,33 €	5,15 €
H013	11032	Radial seal ring, gearbox output for BMW R26, R27 and R50-R69S	6,09 €	7,25 €
H014	06152	Idle indicator switch spring for BMW R25/3, R26 and R27	6,64 €	7,90 €
H015	06158	Idle indicator switch contact bolt for BMW R25/2-R27 and R51/3-R69S	10,76 €	12,80 €
H018	06174	Rubber plug for idle connection for BMW R25/2-R69S	4,20 €	5,00 €
H020	05660	Idle indicator switch hexagon socket screw for BMW R25/2-R27 and R51/3-R69S	1,26 €	1,50 €
H024	12551	Screw for engine / gearbox for BMW R50-R69S, M 8 x 75, hexagon with shaft	0,55 €	0,65 €
H026	98352	Nut M 8 zinked	0,17 €	0,20 €
H026	98352	Nut M 8 zinked	0,17 €	0,20 €
H026	0098352	Nut M 8, wrench size 14 zincked	1,01 €	1,20 €
H026	0098352	Nut M 8, wrench size 14 zincked	1,01 €	1,20 €
H027	2027	Gasket ring oil drain screw, M14x20x2	0,67 €	0,80 €
H028	07163	Oil drain screw for BMW R24-R69S, M14, magnetic zincked	3,19 €	3,80 €
H028A	07104	Oil filler screw for BMW R24-R69S, M14 x 1,5 zincked	2,02 €	2,40 €
H028A	0007104	Oil filler screw for BMW R24-R69S, M14 x 1,5 stainless steel, polished	5,97 €	7,10 €
H028B	0007163	Oil drain screw for BMW R24-R69S, M14, magnetic stainless steel	7,48 €	8,90 €
H029	20005	Gearbox drive shaft for BMW R50-R69S naked, used	105,04 €	125,00 €
H030	20136	Washer earles swing front/inner and gearbox inlet for BMW R50-R69S	2,44 €	2,90 €
H031	00010	Race for seal ring drive shaft for BMW R25-R27 and R50-R69S	7,98 €	9,50 €
H032	4064	Bearing crank shaft for BMW R24-R27 front end and /5 4-speed gearbox and for BMW R24-R69S input shaft front and output shaft rear	7,35 €	8,75 €
H033	9064	Bearing gearbox input shaft for BMW R24-R27 and R50-R69S, rear	6,93 €	8,25 €
H034	20245	Gear-wheel drive shaft for BMW R50-R69S	71,51 €	85,10 €
H035	1083154	Drive coupling intake shaft for BMW R50-R69S	32,77 €	39,00 €
H038	20148	Lock ring input shaft for BMW R24-R27, R50-R69S and R50/5-R75/5	0,63 €	0,75 €
H039	20157	Bearing cover ring for BMW R24-R27 and R50-R69S	1,81 €	2,15 €
H040	20164	Thrust washer gearbox output shaft for BMW R24-R2, R50-R69S and R50/5-R75/5	4,03 €	4,80 €
H041	180176	Clutch thrust rod for BMW R50-R69S	11,93 €	14,20 €
H042	20132	Felt for clutch push rod for BMW R24-R27 and R50-R100 for mounting cut diagonally	2,48 €	2,95 €
H043	30961	Thrust bearing clutch ball bearing for BMW models until year of manufacture 09/1973	21,43 €	25,50 €
H044	080150	Clutch thrust piece for BMW R50-R69S	18,49 €	22,00 €
H045	20109	Sealring for clutch thrust piece	2,52 €	3,00 €
H046	30962	Thrust bearing, clutch for BMW R24-R26 and R51/2-R69S and BMW R50/5 until year of manufacture 09/1973	9,20 €	10,95 €
H047	1080105	Clutch release lever for BMW R50-R69S	43,28 €	51,50 €
H048	20113	Bolt clutch release lever for BMW R26-R69S, 0,5mm oversize stainless steel	6,72 €	8,00 €
H048	20112	Bolt clutch release lever for BMW R26-R69S stainless steel	4,62 €	5,50 €
H049	945180	Split pin for release lever for BMW R26, R27 and R50-R69S and for bolt side stand R50-R69S	0,17 €	0,20 €
H050A	20116	Adjusting screw for clutch release lever for BMW R51/2-R68 and R50-R69S (older models), M6	3,28 €	3,90 €
H050B	30108	Adjusting screw for clutch release lever for BMW R26-R27, R50-69S, R50/5 until year of manufacture 09/1980, M8	2,94 €	3,50 €
H051A	21104	Nut M 8 , flat zincked	0,21 €	0,25 €
H052	80122	Clutch lever spring until year of manufacture 08/1973	1,64 €	1,95 €
H053	40028	Intermediate gear box shaft for BMW R50/2-R69S last version	197,48 €	235,00 €
H053	1040027	Intermediate gear box shaft for BMW R27 and R50 old version	197,48 €	235,00 €
H054	40108	Gear-wheel 4th gear auxiliary shaft for BMW R26-R69S	50,00 €	59,50 €
H055	5148003	Woodruff key gearbox for BMW R24-R27 and R51/3-R69S Intermediate shaft R24-R69S, output shaft R51/3-R68	1,51 €	1,80 €
H056	15064	Bearing auxiliary shaft for BMW R24-R27 and R50-R69S, front front/rear wheel R25-R25/3	22,65 €	26,95 €
H057	6203	Bearing cam shaft R24-R69S, crankshaft R51/3-R69S, front end, with 17mm cone wheel bearing R25-R25/2, pinion shaft R24, auxiliary shaft /5 4-gear box, crankshaft most front R51/3-R69	6,22 €	7,40 €
H058Aa	30027	Gearbox outlet shaft for BMW R50-R69S with key slot	201,60 €	239,90 €
H059	30262	Bushing for BMW R25-R69S, 2nd and 3rd gear	30,17 €	35,90 €
H060	30100	Lock ring output shaft for BMW R24-R27 and R50-R69S, center	1,05 €	1,25 €



H061	1006242	Oil drip pan output shaft for BMW R50-R69S	11,68 €	13,90 €
H062	4064	Bearing crank shaft for BMW R24-R27 front end and /5 4-speed gearbox and for BMW R24-R69S input shaft front and output shaft rear	7,35 €	8,75 €
H063	8064	Bearing output shaft for BMW R24-R27 and R50-R69S, front and for front wheel BMW R24	7,48 €	8,90 €
H064	34090	Lock ring output shaft for BMW R24-R69S, front	0,25 €	0,30 €
H065	1020102	Thrust washer to the 4th. gear wheel for BMW R25-R69S	2,69 €	3,20 €
H066	30153	Gear-wheel 4th gear outputshaft for BMW R26-R69S	134,03 €	159,50 €
H066	30151	Spur wheel 4th gear for BMW R26, R27 and R50-R69S	136,05 €	161,90 €
H066a	1030154	Gear-wheel 3rd gear outputshaft for BMW R26-R69S	134,03 €	159,50 €
H068	1030147	Spur wheel 2nd gear for BMW R50-R69S	134,03 €	159,50 €
H068	1030146	Spur wheel 2nd gear for BMW R50 and R60 "old version"	134,03 €	159,50 €
H069	30242	Spur wheel 1st gear for BMW R50 and R60 "old version"	134,03 €	159,50 €
H069	1030246	Gear wheel 1st speed R50-R69S	134,03 €	159,50 €
H070	30259	Bushing for BMW R25-R69S, 1st gear-wheel	15,13 €	18,00 €
H071	30266	Bushing for BMW R25-R69S, 4th gear-wheel	12,77 €	15,20 €
H072	11016	Sliding claw for BMW R24-R27 and R50-R69S	35,29 €	42,00 €
H073	40104	Thrust washer gearbox output shaft for BMW R25-R69S 1st and 4th gear wheel	4,33 €	5,15 €
H076	1030112	Thrust washer to the spur wheel 1th. gear for BMW R25-R69S	5,50 €	6,55 €
H077	1231651	Distance washer for outlet shaft for BMW R24-R69S, 0,20mm	2,69 €	3,20 €
H077	1231652	Distance washer for outlet shaft for BMW R24-R69S, 0,30mm	2,69 €	3,20 €
H077	1231653	Distance washer for outlet shaft for BMW R24-R69S, 0,38mm	2,69 €	3,20 €
H077	1231654	Distance washer for outlet shaft for BMW R24-R69S, 0,50mm	2,69 €	3,20 €
H077	1231655	Distance washer for outlet shaft for BMW R24-R69S, 0,60mm	2,69 €	3,20 €
H077	1231656	Distance washer for outlet shaft for BMW R24-R69S, 0,75mm	2,69 €	3,20 €
H077	1231657	Distance washer for outlet shaft for BMW R24-R69S, 0,88mm	2,69 €	3,20 €
H077	2231657	Distance washer gearbox outlet shaft for BMW R24-R60S, 0,95mm and wheel bearing for BMW R51/3-R68	2,69 €	3,20 €
H077	1231658	Distance washer for outlet shaft for BMW R24-R69S, 1,00mm	2,69 €	3,20 €
H078A	30296	Gearbox flange for BMW R50-R69S with groove, conus 1:5	86,47 €	102,90 €
H078B	030297	Gearbox flange for BMW R50-R69S without groove, conus 1:6	86,47 €	102,90 €
H079	51461	Woodruff key cam shaft for BMW R51/3-R69S and gearbox flange twins until year of manufacture 1969	1,51 €	1,80 €
H080	30169	Washer M16, DIN988 S for castle nut gearbox flange for BMW R50/2, R60/2 and R69S	0,34 €	0,40 €
H080	30170	Washer M14, DIN988 S for castle nut gearbox flange for BMW R24-R27	0,42 €	0,50 €
H080B	98462	Spring washer B16, DIN137 zincked	0,34 €	0,40 €
H081A	30120	Castle nut gearbox flange M14 for BMW R24-R27 and R51/2-R68 and for BMW R50-R69S (old version) gearbox flange	8,36 €	9,95 €
H081B	30122	Castle nut gearbox flange M16 for BMW R50-R9S (new version)	9,41 €	11,20 €
H082A	30058	Speedo drive for BMW R24-R27 and R50-R69S	41,68 €	49,60 €
H082B	111031	Speedo drive for BMW R24-R27, R50-R69S and /5 used	33,61 €	40,00 €
H083	30176	Bushing speedo-cable for BMW R26-R69S and R50/5-R100 thin end	3,19 €	3,80 €
H084	30174	Speedo cable holding screw with breather hole for BMW R24-R69S stainless steel	5,80 €	6,90 €
H084A	31065	Speedo cable screw with breather hole for BMW R24-R69S zincked	2,35 €	2,80 €
H085A	56120	Kick starter for BMW R25-R27 and R50-R69S, straight model Aluminum	94,83 €	112,85 €
H085b	26016	Kick starter bumper for BMW R51/2-R69S	8,19 €	9,75 €
H085C	34156	Kick starter bumper mounting set for BMW R24-R69S	4,16 €	4,95 €
H086	50016	Mounting bolt for kick starter for BMW R24-R27, R50-R69S and R50/5-R100 zincked	4,16 €	4,95 €
H086A	56124	Mounting bolt for kick starter for BMW R24-R27, R50-R69S and R50/5-R100 stainless steel	5,88 €	7,00 €
H088	98352	Nut M 8 zincked	0,17 €	0,20 €
H088	0098352	Nut M 8, wrench size 14 zincked	1,01 €	1,20 €
H089	56274	Kick starter section gear for BMW R50-R69S used	100,84 €	120,00 €
H090	56104	Kick starter gear wheel, drive shaft for BMW R25-R27 and R50-R69S used	28,12 €	33,46 €
H090a	1056104	Kick starter gear wheel, drive shaft for BMW R25-R27 and R50-R69S new	57,73 €	68,70 €
H091	56116	Spring for input shaft for BMW R25-R27, R50-R69S and R50/5-R75/5	4,20 €	5,00 €
H092	56112	Kick starter spring for BMW R24-R27, R50-R69S and R50/5-R75/5	5,71 €	6,79 €
H093	56108	Kick starter intermediate gear for BMW R24-R27, R50-R69S and R50/5-R75/5	75,55 €	89,90 €
H094	34080	Lock ring kickstarter gear for BMW R24-R27, R50-R69S and R50/5-R75/5R69S	0,25 €	0,30 €
H096	45016	Shift lever rubber for BMW R24-R69S and R50/5-R75/5	1,51 €	1,80 €
H097	30812	Shift lever shim for BMW R25/2-R69S and R50/5-R75/5, 0,75mm	1,26 €	1,50 €
H097	30813	Shift lever shim for BMW R25/2-R69S and R50/5-R75/5, 0,50mm	1,26 €	1,50 €
H097	30811	Shift lever shim for BMW R25/2-R69S and R50/5-R75/5, 1,00mm	1,26 €	1,50 €
H102	66150	Shift lever return spring for BMW R24-R27 and R50-R69S	5,80 €	6,90 €
H104	66146	Lock washer for shifter for BMW R24-R27 and R50-R69S	7,14 €	8,50 €
H107	66130	Spring latch for BMW R24-R27 and R50-R69S, old version	2,69 €	3,20 €
H108	34060	Lock ring switch wafer for BMW R24-R69S and breather cam shaft for BMW R27	0,21 €	0,25 €
H109	34120	Lock ring shifting shaft for BMW R24-R69S, big	0,34 €	0,40 €



H110	34071	Lock ring shifting shaft for BMW R24-R69S, small	0,21 €	0,25 €
H111	66102	Wedge for shift pedal for BMW R24-R69S zinced	3,82 €	4,55 €
H111A	66103	Wedge for shift pedal for BMW R24-R69S stainless steel	6,51 €	7,75 €
H114	1230935	Screw gear positioning, for BMW R50-R69S and R50/5, R60/5, R75/5, upper and lower	0,50 €	0,60 €
H115	98414	Washer M 8, DIN125, Form A cined	0,06 €	0,07 €
H119A	66206	Shifter fork for BMW R24-R27 and R50-R69S	79,83 €	95,00 €
H121	1230086	Excenter bushing shifter fork for BMW R24-R90S	24,87 €	29,60 €
H123	98410	Washer M 6, DIN125, Form A cined	0,05 €	0,06 €
H124	19741	Screw for shifter fork for BMW R50-R69S Allen® head	1,85 €	2,20 €
H125	66131	Spring latch for BMW R50-R69S and R50/5-R75	6,89 €	8,20 €
H126	060107	Thrust washer shifter shaft for BMW R50/2-R69S	1,30 €	1,55 €



Group I: Gearbox all Twins 1948-1956

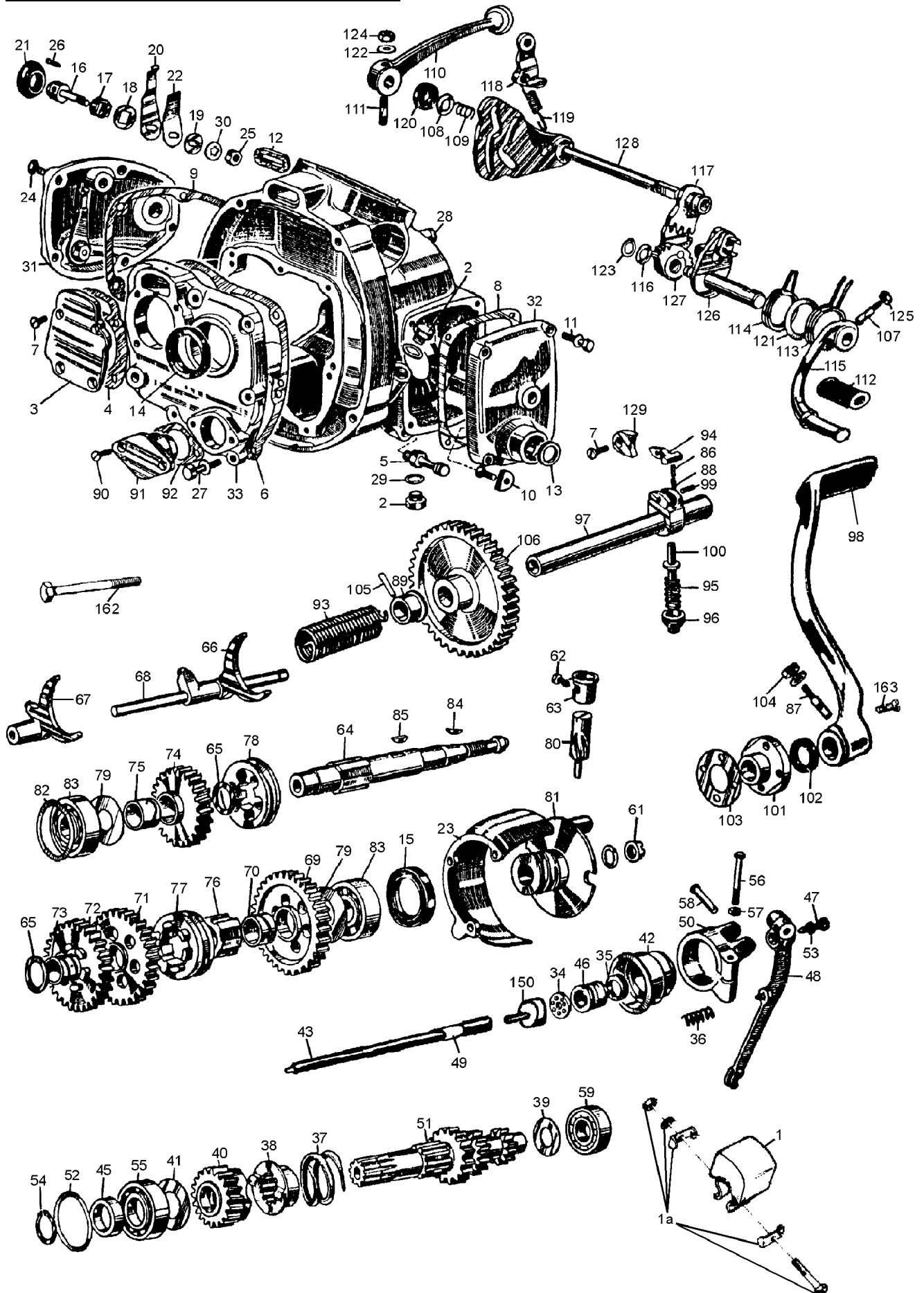

<u>Picture-No.</u>	<u>Article-No.</u>	<u>Description</u>	<u>Net</u>	<u>Gross</u>
I000	600001	Gasket set gearbox (No.G05-1), for BMW R51/2-R68 complete, incl. paper gaskets	41,93 €	49,90 €
I000	12100	Gasket set gearbox (No.G05-2), for BMW R51/2-R68 only paper gaskets	15,46 €	18,40 €
I000	06027	Gearbox for BMW R51/2-R67/3 overhauled, IN EXCHANGE	1.134,45 €	1.350,00 €



I001	26016	Kick starter bumper for BMW R51/2-R69S	8,19 €	9,75 €
I001A	34156	Kick starter bumper mounting set for BMW R24-R69S	4,16 €	4,95 €
I002	07163	Oil drain screw for BMW R24-R69S, M14, magnetic zincked	3,19 €	3,80 €
I002A	07104	Oil filler screw for BMW R24-R69S, M14 x 1,5 zincked	2,02 €	2,40 €
I002A	0007104	Oil filler screw for BMW R24-R69S, M14 x 1,5 stainless steel, polished	5,97 €	7,10 €
I002b	0007163	Oil drain screw for BMW R24-R69S, M14, magnetic stainless steel	7,48 €	8,90 €
I004	06208	Gasket gearbox flange cover for BMW R51/3-R68	2,48 €	2,95 €
I005	06212	Bolt for spring center stand at gear-box for BMW R51/2-R68	11,25 €	13,39 €
I006	06216	Gasket gearbox cover for BMW R51/3-R68	3,91 €	4,65 €
I007	06221	Screw for gearbox flange cover R51/2-R68, 60° countersunk head stainless steel	4,37 €	5,20 €
I008	06232	Gasket foot shift cover for BMW R51/3-R68	2,48 €	2,95 €
I009	06236	Gasket hand shift cover for BMW R51/3-R68	3,78 €	4,50 €
I011	12112	Screw for foot shift cover for BMW R51/3-R68, M 6 x 25 stainless steel, wrench size 9mm	4,45 €	5,30 €
I013	06253	Radial seal ring, foot shift lever for BMW R51/2-R68, R45/R65 and R60/6-R100 from year of manufacture 09/1974 and GS-Models	3,36 €	4,00 €
I014	06261	Radial seal ring, gearbox input for BMW R51/3-R68	4,37 €	5,20 €
I015	30272	Radial seal ring, gearbox output for BMW R51/3-R68	7,02 €	8,35 €
I016	06158	Idle indicator switch contact bolt for BMW R25/2-R27 and R51/3-R69S	10,76 €	12,80 €
I021	06174	Rubber plug for idle connection for BMW R25/2-R69S	4,20 €	5,00 €
I023	30276	Protecting bell driving plate for BMW R51/3-R68	41,93 €	49,90 €
I024	10169	Screw-Set for hand shifter cover for BMW R51/3-R68, (6 pieces) stainless steel polished	23,61 €	28,10 €
I026	05660	Idle indicator switch hexagon socket screw for BMW R25/2-R27 and R51/3-R69S	1,26 €	1,50 €
I027	98169	Screw M 6 x 25, hexagon stainless steel	0,42 €	0,50 €
I027	98161	Screw M 6 x 25, hexagon	0,15 €	0,18 €
I028	98150	Screw M 6 x 10, hexagon stainless steel	0,20 €	0,24 €
I028	98156	Screw M 6 x 10, hexagon	0,13 €	0,15 €
I03	98454	Spring washer B 6, DIN137 zincked	0,05 €	0,06 €
I031	12029	Cover for hand shifter for BMW R51/3-R68 used	58,82 €	70,00 €
I032	12025	Cover for foot control for BMW R51/3-R68 used	17,90 €	21,30 €
I034	30961	Thrust bearing clutch ball bearing for BMW models until year of manufacture 09/1973	21,43 €	25,50 €
I035	20109	Sealring for clutch thrust piece	2,52 €	3,00 €
I036	80122	Clutch lever spring until year of manufacture 08/1973	1,64 €	1,95 €
I037	20252	Pressure spring drive shaft for BMW R51/3-R68 used	8,44 €	10,04 €
I038	20204	Drive coupling intake shaft for BMW R51/3-R68	16,72 €	19,90 €
I040	20217	Spur wheel 4th gear input shaft for BMW R51/3-R68 used	38,35 €	45,64 €
I042	80147	Clutch lever bushing for BMW R51/3-R68	37,77 €	44,95 €
I043B	80173	Clutch thrust rod for BMW R51/3-R68 with square-end	13,36 €	15,90 €
I045	00011	Race for seal ring gearbox input for BMW R51/3-R68	6,72 €	8,00 €
I046	20107	Clutch thrust piece for BMW R51/3-R68	18,49 €	22,00 €
I047	20116	Adjusting screw for clutch release lever for BMW R51/2-R68 and R50-R69S (older models), M6	3,28 €	3,90 €
I049	80156	Felt for clutch push rod for BMW R51/2-R68 for mounting cut diagonally	2,98 €	3,55 €
I050A	080167	Clutch release lever for BMW R51/3-R68, complete	81,81 €	97,35 €
I053A	98324	Nut M 6, flat zincked	0,10 €	0,12 €
I053B	98322	Nut M 6, flat stainless steel	0,17 €	0,20 €
I055	11064	Bearing gearbox input shaft for BMW R51/2-R68, front	7,82 €	9,31 €
I056	98179	Screw M 6 x 45, hexagon with shaft	0,25 €	0,30 €
I057	98323	Nut M 6 zincked	0,13 €	0,15 €
I058A	40444	Bolt clutch release lever for BMW R51/3-R68 steel zincked	2,94 €	3,50 €
I058B	40445	Bolt clutch release lever for BMW R51/3-R68 stainless steel	4,62 €	5,50 €
I059	85702	Bearing gearbox (roller bearing) input shaft for BMW R51/3-R68, rear	30,00 €	35,70 €
I061	30120	Castle nut gearbox flange M14 for BMW R24-R27 and R51/2-R68 and for BMW R50-R69S (old version) gearbox flange	8,36 €	9,95 €
I062	30174	Speedo cable holding screw with breather hole for BMW R24-R69S stainless steel	5,80 €	6,90 €
I062A	31065	Speedo cable screw with breather hole for BMW R24-R69S zincked	2,35 €	2,80 €
I063	30128	Bushing speedo-cable for BMW R25-R25/3 and R51/3-R68 fat end	8,32 €	9,90 €
I065	1030220	Thrust washer to shifting-fork for BMW R51/2-R68	4,96 €	5,90 €
I066	70015	Shifter fork for BMW R51/2-R68, 1./2. speed	92,02 €	109,50 €
I067	70016	Shifter fork for BMW R51/2-R68, 3./4. speed	92,02 €	109,50 €
I068	66208	Shifter fork axle for BMW R51/3-R68	24,54 €	29,20 €
I070	30257	Bushing for BMW R51/2-R68, 1st gear	11,26 €	13,40 €
I073	30261	Bushing for BMW R51/2-R68, 2nd and 3rd gear	14,24 €	16,95 €
I075	30264	Bushing for BMW R51/2-R68, 4th gear	12,44 €	14,80 €
I077	119016	Sliding claw for BMW R51/3-R68, 1/2. gear (with pin)	75,38 €	89,70 €
I078	120016	Sliding claw for BMW R51/3-R68, 3./4. gear	35,29 €	42,00 €
I080	112031	Speedo drive for BMW R51/2-R68 original BMW, REMNANTS	41,93 €	49,90 €



I081	30289	Gearbox flange for BMW R51/2-R68 new	147,06 €	175,00 €
I082A	33474	Distance washer gearbox outlet shaft for BMW R51/3-R68 and all 5-gear, 0,10mm	1,51 €	1,80 €
I082A	33475	Distance washer gearbox outlet shaft for BMW R51/3-R68 and all 5-gear, 0,20mm	1,51 €	1,80 €
I082B	31625	Distance washer gearbox outlet shaft for BMW R51/3-R68 and all 5-gear, 0,30mm	1,60 €	1,90 €
I082C	31626	Distance washer gearbox outlet shaft for BMW R51/3-R68 and all 5-gear, 0,38mm	8,49 €	10,10 €
I082D	31627	Distance washer gearbox outlet shaft for BMW R51/3-R68 and all 5-gear, 0,50mm	1,60 €	1,90 €
I083	1064	Grooved ball bearing gearbox outlet shaft for BMW R51/2-R68, front and rear and for BMW /5 - 4-gear- and 5-gearbox	7,73 €	9,20 €
I084	51461	Woodruff key cam shaft for BMW R51/3-R69S and gearbox flange twins until year of manufacture 1969	1,51 €	1,80 €
I085	5148003	Woodruff key gearbox for BMW R24-R27 and R51/3-R69S Intermediate shaft R24-R69S, output shaft R51/3-R68	1,51 €	1,80 €
I086	1056208	Pressure spring for kick starter safety catch for BMW R51/2-R68	1,26 €	1,50 €
I087	56205	Mounting bolt for kick starter for BMW R51/2-R68 zincd	3,82 €	4,55 €
I087B	56204	Mounting bolt for kick starter for BMW R51/2-R68 stainless steel	6,39 €	7,60 €
I090	06221	Screw for gearbox flange cover R51/2-R68, 60° countersunk head stainless steel	4,37 €	5,20 €
I092	12154	Gasket gearbox kicker cover for BMW R51/3-R68	2,48 €	2,95 €
I093	56225	Kick starter spring for BMW R51/2-R68 used	8,61 €	10,25 €
I094	60016	Kick starter lock piece for BMW R51/2-R68	32,77 €	39,00 €
I097	56025	Kick starter shaft for BMW R51/2-R68 used	17,90 €	21,30 €
I098	56257	Kick starter for BMW R51/2-R68 stainless steel	102,27 €	121,70 €
I101	56221	Flange kick starter shaft for BMW R51/2-R68 used	10,34 €	12,30 €
I102	02197	Radial seal ring, crankshaft front for BMW R50/2-R69S and kick starter for BMW R51/3-R68	3,70 €	4,40 €
I103	02188	Gasket kick start shaft for BMW R51/3-R68	2,48 €	2,95 €
I107	66103	Wedge for shift pedal for BMW R24-R69S stainless steel	6,51 €	7,75 €
I107	66102	Wedge for shift pedal for BMW R24-R69S zincd	3,82 €	4,55 €
I109	1066216	Pressure spring hand shifter cover for BMW R51/2-R68	2,52 €	3,00 €
I110	66229	Hand shift lever for BMW R51/3-R68, long, 20cm	19,83 €	23,60 €
I110	6666229	Hand shift lever for BMW R51/3-R68, short, 13cm	18,40 €	21,90 €
I111	190017	Wedge for hand lever for BMW R24-R25/2 and R51/2-R68 stainless steel	5,88 €	7,00 €
I111A	66122	Wedge for hand lever for BMW R24-R25/2 and R51/2-R68 zincd	4,20 €	5,00 €
I112	45016	Shift lever rubber for BMW R24-R69S and R50/5-R75/5	1,51 €	1,80 €
I113	66234	Shift lever return spring for BMW R51/2-R68, outer	11,51 €	13,70 €
I114	66238	Shift lever return spring for BMW R51/2-R68, inner	10,84 €	12,90 €
I115	66242	Foot shift lever for BMW R51/2, R51/3, R67 und R68 used	61,30 €	72,95 €
I119	66258	Spring for ratched for BMW R51/2-R68, shifting-automat	6,68 €	7,95 €
I120	66225	Radial seal ring, hand shift lever for BMW R51/3-R68	3,36 €	4,00 €
I120a	1066224	Felt ring for handshifter for BMW R51/2	2,10 €	2,50 €
I162	12535	Screw for engine / gearbox for BMW R51/3-R68, M 8 x 65, hexagon with shaft	0,46 €	0,55 €
I163	98132	Screw M 5 x 16, raised countersunk head stainless steel	0,34 €	0,40 €



Group K: Rear transmission R25, R25/2, R25/3

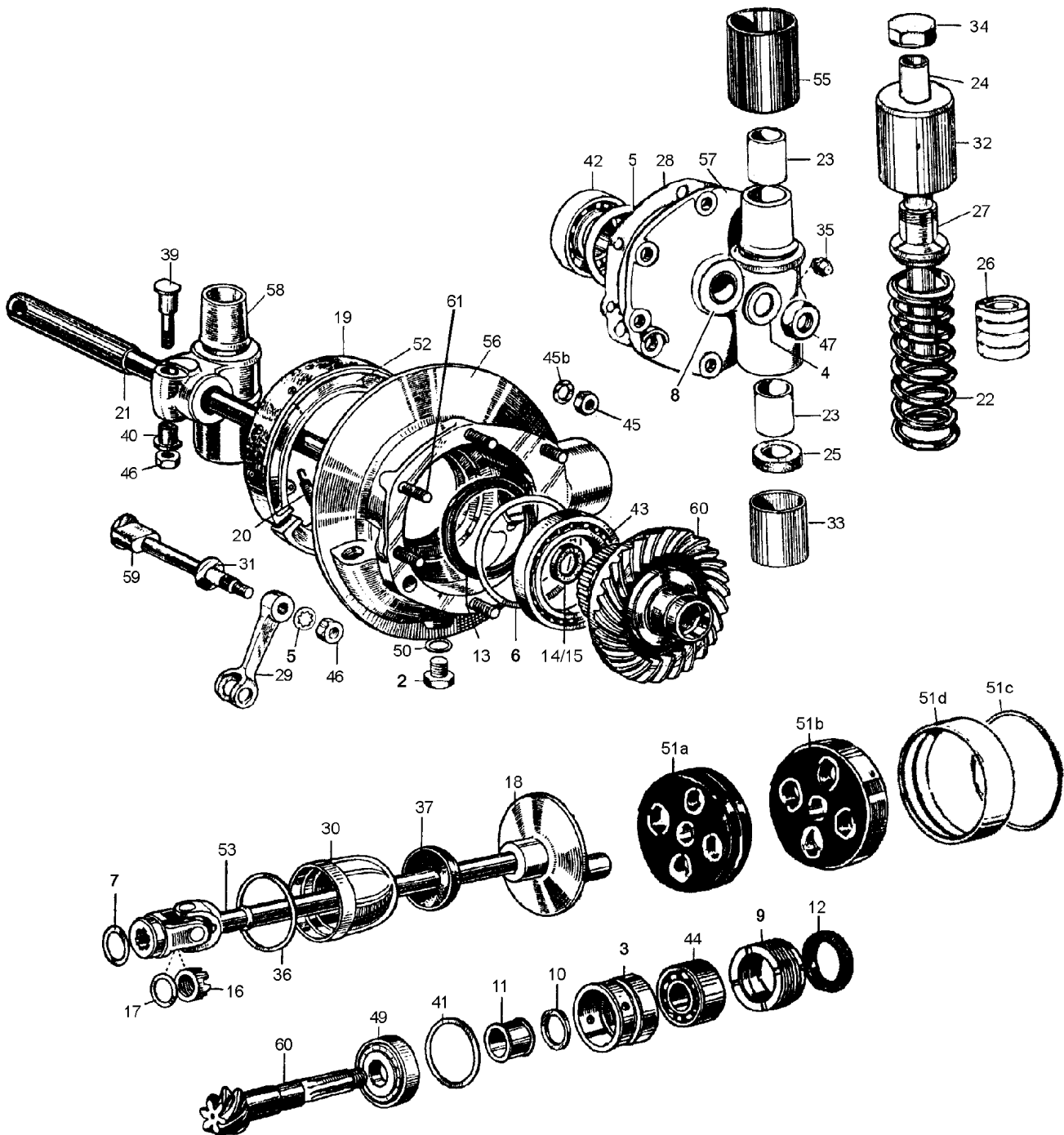

<u>Picture-No.</u>	<u>Article-No.</u>	<u>Description</u>	<u>Net</u>	<u>Gross</u>
K000	38149	Cardan shaft protecting ring for BMW R24	7,23 €	8,60 €
K000	3038149	Boot real drive shaft for BMW R24 and kickstart shaft for BMW R51/2-R68 with circular spring	15,04 €	17,90 €
K002	07163	Oil drain screw for BMW R24-R69S, M14, magnetic zinced	3,19 €	3,80 €
K002	0007163	Oil drain screw for BMW R24-R69S, M14, magnetic stainless steel	7,48 €	8,90 €
K003	38101	Bearing bushing rear drive for BMW R25, R25/2 and R25/3	4,09 €	4,87 €
K004	04378	Washer for wheel axle for BMW R24-R69S cinced	0,38 €	0,45 €
K004	31089	Washer for wheel axle for BMW R24-R69S stainless steel polished	4,86 €	5,78 €
K007	38125	Distance washer cardan shaft for BMW R25, R25/2 and R25/3	0,46 €	0,55 €
K009	38129	Threaded connection rear drive for BMW R25, R25/2 and R25/3 used	12,52 €	14,90 €
K012	38172	Radial seal ring, transmission input for BMW R25, R25/2 and R25/3	4,54 €	5,40 €
K013	13032	Radial seal ring, crown wheel for BMW R25-R27	7,48 €	8,90 €
K014	04178	Felt ring for crown-wheel for BMW R25, R25/2 and R25/3	2,94 €	3,50 €
K016	38142	Drive shaft nut for BMW R25-R27	4,03 €	4,80 €
K017	38144	Washer drive shaft nut for BMW R25, R26 and R27	0,38 €	0,45 €
K018A	120031	Flange drive shaft for BMW R25, R25/2 and R25/3 used	57,14 €	68,00 €
K018B	3000	Pressing cardan flange off / on for BMW R24-R25/3 and R51/2-R68	28,07 €	33,40 €
K019A	4051	Brake lining for BMW R25 and R 25/2	10,00 €	11,90 €



K019B	2051	Brake lining for BMW R25/3, R26 and R27	10,00 €	11,90 €
K020	60134	Brake-shoe spring for BMW R25-R27	2,48 €	2,95 €
K021	04161	Wheel axle for BMW R25, R25/2 and R25/3, rear chromed	50,34 €	59,90 €
K022A	04168	Spring for BMW R25 and R25/2, rear suspension for solo and sidecar use	17,65 €	21,00 €
K022B	54004	Spring for BMW R25/3, rear suspension for solo and sidecar use	14,20 €	16,90 €
K023A	54101	Bushing for rear suspension for BMW R25 and R25/2	9,20 €	10,95 €
K023B	54103	Bushing for rear suspension for BMW R25/3	11,22 €	13,35 €
K024	954111	Suspension tube for BMW R25/3 and R51/3-R68	23,53 €	28,00 €
K024A	54110	Suspension tube for BMW R25	23,53 €	28,00 €
K024A	54109	Suspension tube for BMW R25 and R25/2 used	10,84 €	12,90 €
K024AA	9954110	Suspension tube for BMW R25/2	41,93 €	49,90 €
K025	54120	Rear suspension bump stop rubber for BMW R25, R25/2 and R25/3	2,77 €	3,30 €
K025B	20136	Washer earles swing front/inner and gearbox inlet for BMW R50-R69S	2,44 €	2,90 €
K025C	054217	Washer bump stop rubber for BMW R25/3 and R51/2-R68 rear drive spring system	1,85 €	2,20 €
K027C	054128	Suspension clamping part for BMW R25/3, rear wheel spring system	25,13 €	29,90 €
K028	04164	Gasket for rear drive cover for BMW R25, R25/2 and R25/3	2,27 €	2,70 €
K029A	60108	Brake lever for BMW R25 and R25/2, rear used	10,84 €	12,90 €
K029B	060111	Brake lever for BMW R25/3, rear used	10,84 €	12,90 €
K030A	38176	Drive shaft protecting bell for BMW R25 and R25/2	28,32 €	33,70 €
K030B	38178	Drive shaft protecting bell for BMW R25/3 Aluminium	27,56 €	32,80 €
K032A	10077	Shock cover for BMW R25 and R25/2, rear top aluminum	13,28 €	15,80 €
K032B	1077	Shock cover for BMW R25/3, rear top, 66mm aluminum	13,28 €	15,80 €
K032C	0007848	Shock cover for BMW R25/3, rear top, 70mm aluminum	13,28 €	15,80 €
K033A	54141	Grease cup for BMW R25 and R25/2, rear suspension tin	9,03 €	10,75 €
K033B	54143	Grease cup for BMW R25/3, rear suspension Aluminium	10,84 €	12,90 €
K034A	54117	Cap nut (octagonal) for rear shock for BMW R25/3 stainless steel	28,32 €	33,70 €
K034B	0054114	Aluminium cap rear suspension for BMW R25	12,60 €	14,99 €
K034C	18029	Cap nut (octagonal) for rear shock for BMW R25/2 stainless steel	21,85 €	26,00 €
K035	38133	Grease port, M6x0,75x5, wrench size 7, fine thread	2,44 €	2,90 €
K036	38195	Gasket ring for drive shaft bell for BMW R25-R25/3	2,44 €	2,90 €
K037A	24016	Drive shaft protecting rubber for BMW R25-R25/3 and R51/2-R68, white	4,03 €	4,80 €
K037B	38170	Drive shaft protecting rubber for BMW R25-R25/3 and R51/2-R68, black	4,03 €	4,80 €
K039	04214	Axle bolt for BMW R25-R68, rear used	8,32 €	9,90 €
K039A	04210	Axle bolt for BMW R25/2-R68, rear, complete	23,49 €	27,95 €
K039AA	0004210	Axle bolt for BMW R25/2-R68, rear zincked	16,39 €	19,50 €
K042	2064	Bearing crank shaft for BMW R24-R27, front and R24-R25/3, rear and crown wheel outer for BMW R25, R26 and R27	10,42 €	12,40 €
K043	12064	Bearing crown wheel for BMW R25-R27	33,53 €	39,90 €
K044	82460	Bearing pinion shaft for BMW R24-R27	28,07 €	33,40 €
K045A	22093	Nut M 8 x 1 zincked	0,25 €	0,30 €
K045B	22082	Spring washer B 8, DIN137A zincked	0,08 €	0,10 €
K045C	99001	Nut M 8 x 1, fine pitch thread stainless steel	0,97 €	1,15 €
K046	98365	Nut M10 x 1, fine pitch thread stainless steel	1,26 €	1,50 €
K047A	22155	Nut M14 x 1,5 for wheel axle for BMW R24-R69S zincked	0,76 €	0,90 €
K047B	98388	Nut M14 x 1,5 for wheel axle for BMW R24-R69S stainless steel	1,93 €	2,30 €
K049	85905	Bearing pinion shaft (roller bearing) for BMW R25, R25/2 and R25/3	75,55 €	89,90 €
K051A	28016	Driving plate for BMW R24-R25/3 and R51/2-R68, naked WITHOUT chrome ring	14,83 €	17,65 €
K051B	99904	Driving plate for BMW R24-R25/3 and R51/2-R68, complete with chrome ring	30,17 €	35,90 €
K051C	38105	Lock washer driving plate for BMW R24-R27 and R51/2-R68	4,03 €	4,80 €
K051D	38179	Driving plate chrome ring for BMW R24-R27 and R51/2-R68	14,83 €	17,65 €
K052	6010301	Brake-shoe Set for BMW R25/3, R26 and R27, NEW (Set = 2pc. for 1 front or rear wheel)	40,67 €	48,40 €
K053A	2031	Drive shaft for BMW R25, R25/2 and R25/3, USED WITHOUT flange and bell, u-joint in good condition!!!	159,66 €	190,00 €
K053B	38014	Drive shaft for BMW R25, R25/2 and R25/3, completely rebuilt USED, with new or good u-joint, new bell and new rubber	252,02 €	299,90 €
K053C	3034	Repair of universal joint, labour and u-joint	76,64 €	91,20 €
K053D	99923	U-joint for BMW R24-R25/3	41,93 €	49,90 €
K055A	4077	Shock cover for BMW R25 and R25/2, rear lower black, steel	11,26 €	13,40 €
K055B	54147	Shock cover for BMW R25/3, rear lower, black Ø=60mm	11,26 €	13,40 €
K058A	04218	Suspension unit holder for BMW R25 and R25/2 used	33,61 €	40,00 €
K058B	04222	Suspension unit holder for BMW R25/3, left side used	42,02 €	50,00 €
K059A	060104	Brake spanner for BMW R25-R25/2, rear used	12,86 €	15,30 €
K059B	060103	Brake spanner for BMW R25/3, rear used	12,86 €	15,30 €
K060B	38193	Crown and pinion wheel set 25:6 for BMW R25/3, solo	394,87 €	469,90 €
K061	03503	Stud bolt drive cover for BMW R25-R27 and R50-R69S stainless steel	3,36 €	4,00 €
K999	04006	Rear drive for BMW R25 and R25/2, 27:6 overhauled	806,72 €	960,00 €
K999	600024	Gasket set rear drive (No.A01), for BMW R24 complete (7 Parts)	41,93 €	49,90 €



K999	04007	Rear drive für BMW R25/3, 25:6 overhauled	806,72 €	960,00 €
K999	6000015	Gasket set rear drive (No.A02), for BMW R25, R25/2 and R25/3	17,02 €	20,25 €

Group C: Rear transmission all Twins 1948-1956

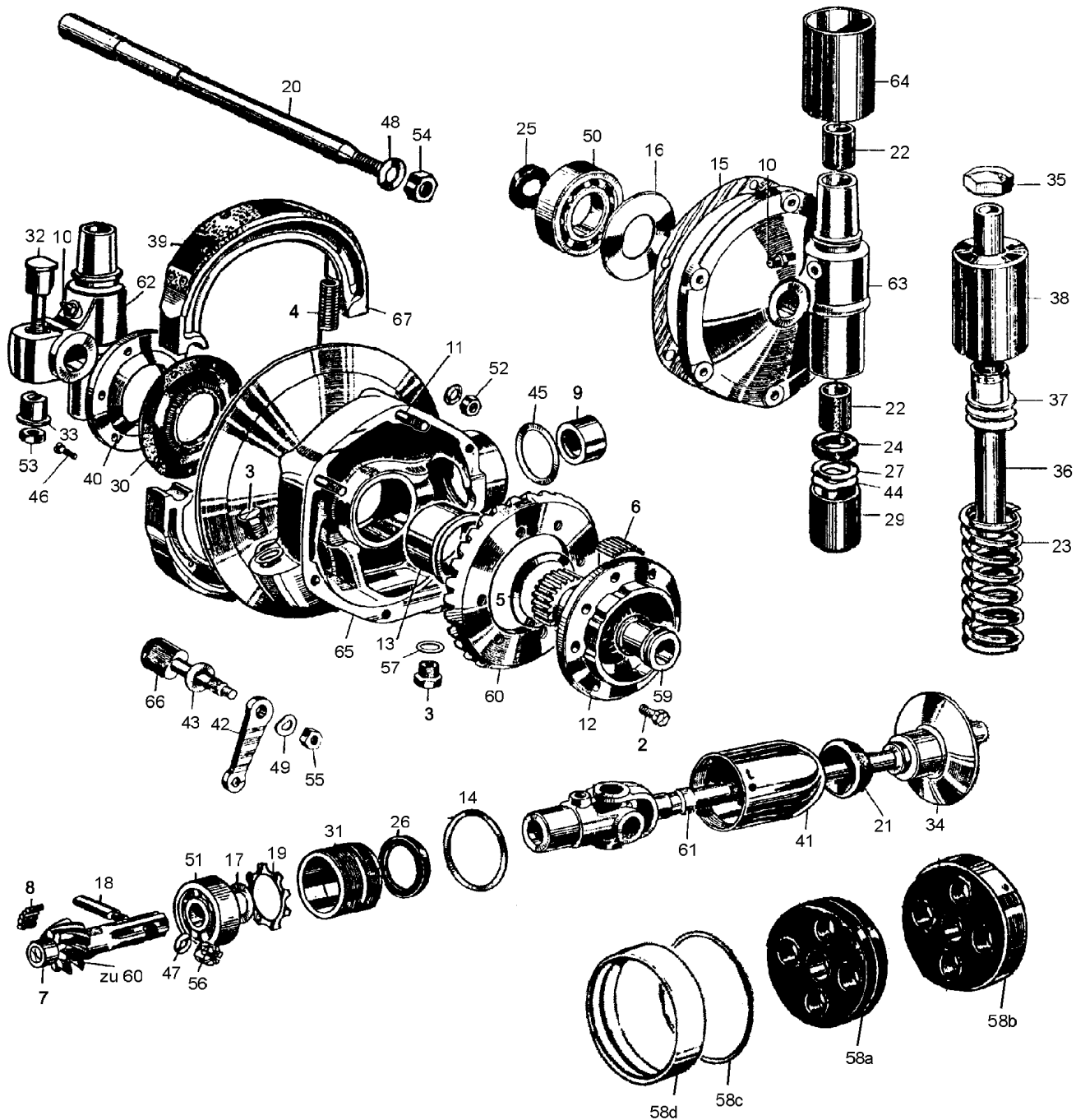

<u>Picture-No.</u>	<u>Article-No.</u>	<u>Description</u>	<u>Net</u>	<u>Gross</u>
C000	600002	Gasket set rear drive (No.A04), for BMW R51/2-R68	19,83 €	23,60 €
C002	04150	Screw for crown wheel for BMW R51/3-R68 with safty hole, M 8 x 1	4,37 €	5,20 €
C003	07163	Oil drain screw for BMW R24-R69S, M14, magnetic zincked	3,19 €	3,80 €
C003	0007163	Oil drain screw for BMW R24-R69S, M14, magnetic stainless steel	7,48 €	8,90 €
C004	60237	Brake-shoe spring for BMW R51/3-R69S, front and rear lower	2,73 €	3,25 €
C006	34191	Needle for crown wheel bearing	0,25 €	0,30 €
C008	38296	Needle for pinion wheel bearing for BMW R24-R25/3 and R51/2-R68 You need for one set = 28 pieces	0,17 €	0,20 €
C009	38298	Needle bearing for pinion wheel for BMW R51/2-R68	20,97 €	24,95 €
C010	38133	Grease port, M6x0,75x5, wrench size 7, fine thread	2,44 €	2,90 €
C011	04323	Stud bolt drive cover for BMW R51/3-R68	2,48 €	2,95 €
C012	04331	Coupling crown wheel for BMW R51/3-R68	147,06 €	175,00 €
C012A	04332	Coupling wheel hub for BMW R51/3-R68 (for repro hub only)	61,64 €	73,35 €
C012B	04355	Felt ring for crown-wheel for BMW R51/2-R68	2,48 €	2,95 €
C013	04382	Bushing rear drive for BMW R51/3-R68	50,38 €	59,95 €
C014	38196	Gasket ring for drive shaft bell for BMW R51/2-R68	2,44 €	2,90 €
C015	04360	Gasket for rear drive for BMW R51/3	3,19 €	3,80 €



C016	3004362	Distance washer transmission-unit/cover for BMW R51/2-R68, 0.50mm	7,48 €	8,90 €
C016a	3004363	Distance washer transmission-unit/cover for BMW R51/2-R68, 0.60mm	7,48 €	8,90 €
C016b	3004364	Distance washer transmission-unit/cover for BMW R51/2-R68, 0.75mm	7,48 €	8,90 €
C016c	3004365	Distance washer transmission-unit/cover for BMW R51/2-R68, 0.88mm	7,48 €	8,90 €
C018	38288	Wedge for drive shaft for BMW R51/2-R68	5,00 €	5,95 €
C020	04366	Wheel axle for BMW R51/2-R68, rear	58,57 €	69,70 €
C021A	24016	Drive shaft protecting rubber for BMW R25-R25/3 and R51/2-R68, white	4,03 €	4,80 €
C021B	38170	Drive shaft protecting rubber for BMW R25-R25/3 and R51/2-R68, black	4,03 €	4,80 €
C022	54312	Bushing for rear suspension for BMW R51/2-R68	9,20 €	10,95 €
C023A	54028	Spring for BMW R51/2-R68, rear suspension for solo use	14,20 €	16,90 €
C023B	54027	Spring for BMW R51/2-R68, rear suspension for sidecar use	14,20 €	16,90 €
C024	54215	Rear suspension bump stop rubber for BMW R51/2-R68	2,77 €	3,30 €
C026	5027	Radial seal ring, transmission input for BMW R51/3-R68	6,09 €	7,25 €
C027	054217	Washer bump stop rubber for BMW R25/3 and R51/2-R68 rear drive spring system	1,85 €	2,20 €
C029	54234	Grease cup for BMW R51/2-R68, rear suspension tin	9,41 €	11,20 €
C030	04370	Boot crown wheel for BMW R51/3-R68	9,20 €	10,95 €
C030	3004390	Spring for Boot crown wheel for BMW R51/2 ONLY for original R51/2-Boot, REMNANTS!!!	9,20 €	10,95 €
C031	38281	Threaded connection rear drive for BMW R51/3-R68	26,30 €	31,30 €
C032	04214	Axle bolt for BMW R25-R68, rear used	8,32 €	9,90 €
C032A	04210	Axle bolt for BMW R25/2-R68, rear, complete	23,49 €	27,95 €
C032AA	0004210	Axle bolt for BMW R25/2-R68, rear zincked	16,39 €	19,50 €
C032B	3004209	Axle bolt ONLY for BMW R25 and R51/2, rear	11,09 €	13,20 €
C034A	038274	Flange drive shaft for BMW R51/2-R68 chromed	100,84 €	120,00 €
C034B	3000	Pressing cardan flange off / on for BMW R24-R25/3 and R51/2-R68	28,07 €	33,40 €
C035A	54321	Cap nut (hexagonal) for rear shock for BMW R51/3-R68 chromed	16,72 €	19,90 €
C035B	54322	Cap nut (hexagonal) for rear shock for BMW R51/3-R68 stainless steel, polished	17,90 €	21,30 €
C035C	54114	Aluminium cap rear suspension for BMW R51/2	10,84 €	12,90 €
C036	954111	Suspension tube for BMW R25/3 and R51/3-R68	23,53 €	28,00 €
C037A	54327	Suspension clamping part for BMW R51/3-R68, rear	27,14 €	32,30 €
C038	5077	Shock cover for BMW R51/2-R68, rear upper aluminium	13,28 €	15,80 €
C039A	5051	Brake lining for BMW R51/2-R68, semi-hub	10,00 €	11,90 €
C039B	3051	Brake lining for BMW R51/3-R68, full-hub	10,00 €	11,90 €
C039C	0008051	Rivet bolts brake lining for BMW R51/2-R69S, 50 pcs., 10mm long	3,36 €	4,00 €
C040	04373	Oil drip cover reardrive for BMW R51/3-R68 used	9,20 €	10,95 €
C041	038270	Drive shaft protecting bell for BMW R51/2-R68 aluminum polished	32,69 €	38,90 €
C041a	67016	Cardan cover bell, chromeplated R25-68	29,33 €	34,90 €
C042	60201	Brake lever for BMW R51/3-R68, rear, semi-hub	5,80 €	6,90 €
C048	04378	Washer for wheel axle for BMW R24-R69S zincked	0,38 €	0,45 €
C048	31089	Washer for wheel axle for BMW R24-R69S stainless steel polished	4,86 €	5,78 €
C049A	22083	Spring washer B10, DIN137A zincked	0,17 €	0,20 €
C049B	22082	Spring washer B 8, DIN137A zincked	0,08 €	0,10 €
C050	3064	Bearing crank shaft for BMW R26 and R27, rear and R51/2-R69S and crownwheel for BMW R51/3-R68, outer	12,44 €	14,80 €
C051	18064	Bearing pinion shaft for BMW R51/2-R69S	29,37 €	34,95 €
C051a	0018064	Bearing pinion shaft for BMW R51/2-R69S reinforced, metal cage	58,74 €	69,90 €
C052	22093	Nut M 8 x 1 zincked	0,25 €	0,30 €
C052B	99001	Nut M 8 x 1, fine pitch thread stainless steel	0,97 €	1,15 €
C053	22122	Nut M10 x 1 zincked	0,34 €	0,40 €
C054A	22155	Nut M14 x 1,5 for wheel axle for BMW R24-R69S zincked	0,76 €	0,90 €
C054B	98388	Nut M14 x 1,5 for wheel axle for BMW R24-R69S stainless steel	1,93 €	2,30 €
C055A	21615	Nut M10 x 1, flat for brake-key and shockabsorber, rear	0,50 €	0,60 €
C055B	22094	Nut M 8 x 1, flat for brake key	0,29 €	0,35 €
C056	23420	Castle nut M 8x1 zincked, fine thread	1,51 €	1,80 €
C057	2027	Gasket ring oil drain screw, M14x20x2	0,67 €	0,80 €
C058A	28016	Driving plate for BMW R24-R25/3 and R51/2-R68, naked WITHOUT chrome ring	14,83 €	17,65 €
C058B	99904	Driving plate for BMW R24-R25/3 and R51/2-R68, complete with chrome ring	30,17 €	35,90 €
C058C	38105	Lock washer driving plate for BMW R24-R27 and R51/2-R68	4,03 €	4,80 €
C058D	38179	Driving plate chrome ring for BMW R24-R27 and R51/2-R68	14,83 €	17,65 €
C059	3004357	Coupling distance sleeve for BMW R51/2-R68 on crown wheel	10,34 €	12,30 €
C060	04026	Crown and pinion wheel set 37:8 for BMW R51/2-R68, sidecar	180,63 €	214,95 €
C060A	10150	Crown and pinion wheel set 35:9 for BMW R51/2-R68, solo	180,63 €	214,95 €
C061	38027	Drive shaft for BMW R51/2-R68, complete	378,15 €	450,00 €
C061B	3034	Repair of universal joint, labour and u-joint	76,64 €	91,20 €
C061C	99921	U-joint for BMW R51/2-R68, R50-R69S and R50/5-R100 (all models)	38,32 €	45,60 €
C062	04422	Suspension unit holder for BMW R51/2-R68, left side used	100,84 €	120,00 €
C064	54236	Shock cover for BMW R51/3-R68, rear lower black, steel	11,26 €	13,40 €



C066	060211	Brake spanner for BMW R51/3-R68, rear, half hub	10,84 €	12,90 €
C066	060210	Brake spanner for BMW R51/3-R68, rear, full hub used	41,18 €	49,00 €
C067	60200	Brake-shoe Set for BMW R51/2-R68, semi-hub, simplex (Set = 2 pc. for 1 front or rear wheel)	40,67 €	48,40 €
C999	04043	Rear drive for BMW R51/3-R68 overhauled	1.218,49 €	1.450,00 €

Group P: Rear swing arm and transmission all models 1955-1969

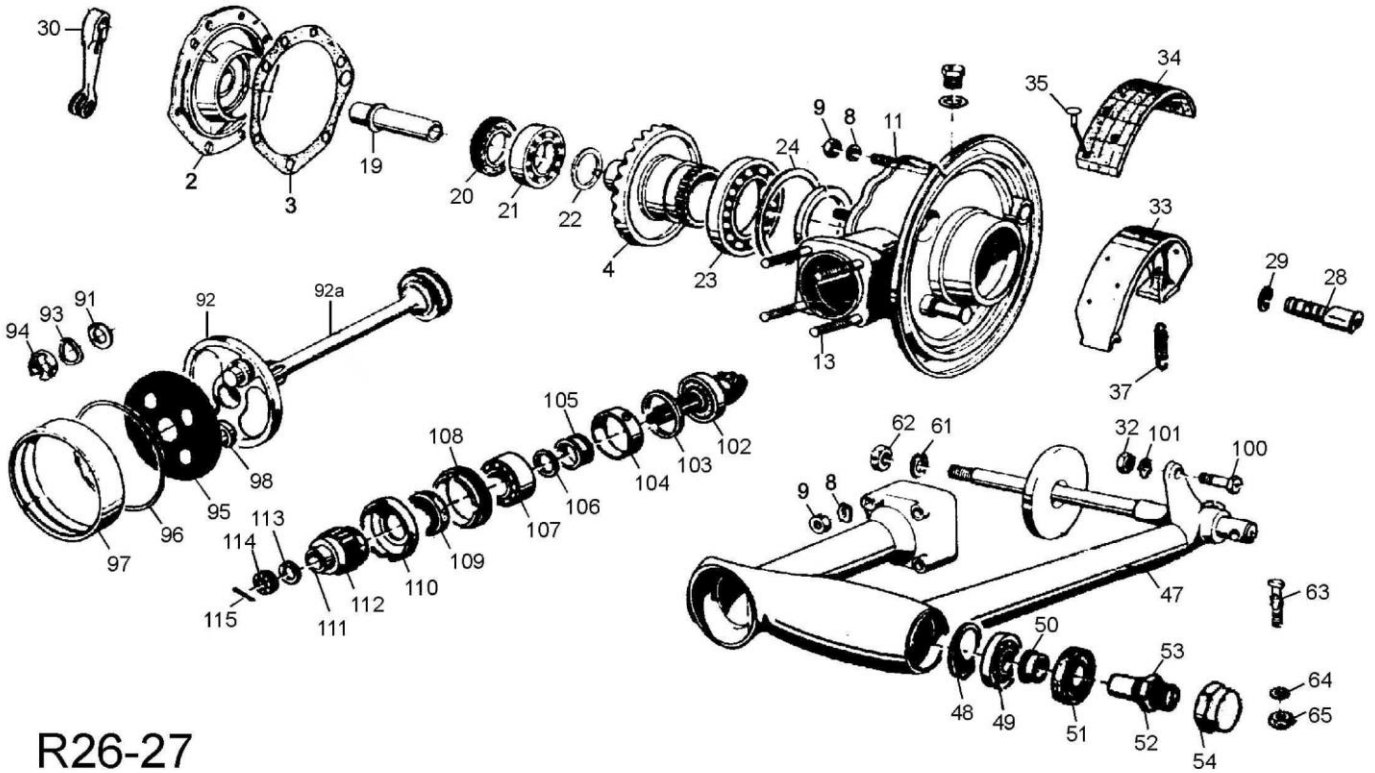

R26-27

R50-69S

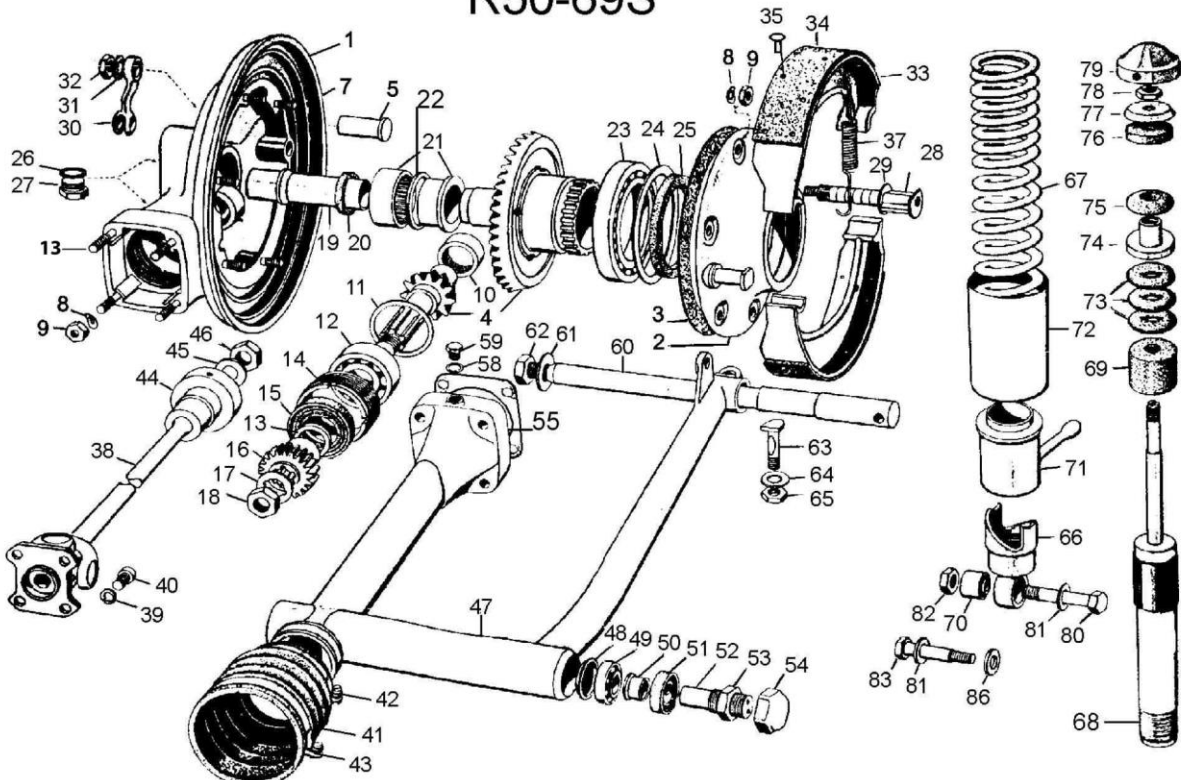

<u>Picture-No.</u>	<u>Article-No.</u>	<u>Description</u>	<u>Net</u>	<u>Gross</u>
P000	600019	Gasket set rear drive (No.A03), for BMW R26-R27	24,79 €	29,50 €



P000	9998450	Spring washer B 4, DIN137B stainless steel	0,10 €	0,12 €
P000	600012	Gasket set rear drive (No.A05), for BMW R50-R69S	17,90 €	21,30 €
P000	45415	Cover for engine breather rear drive for BMW R50-R69S	7,73 €	9,20 €
P001	04031	Rear drive for BMW R50-R69S overhauled	1.218,49 €	1.450,00 €
P001	04014	Rear drive for BMW R26 and R27 overhauled	806,72 €	960,00 €
P001	04032	Rear drive housing for BMW R50-R69S	394,87 €	469,90 €
P003	04162	Gasket for rear drive cover for BMW R26 & R27	2,65 €	3,15 €
P003	04320	Gasket for rear drive cover for BMW R50-R69S	3,19 €	3,80 €
P004	101851	Crown and pinion wheel set 27:7 for BMW R50-R69S, sidecar reproduction	475,21 €	565,50 €
P004	10173	Crown and pinion wheel set 25:7 for BMW R50S, solo	469,75 €	559,00 €
P004	20001	Crown and pinion wheel set 26:6 for BMW R50-R69S, sidecar	483,19 €	575,00 €
P004A	38189	Crown and pinion wheel set 25:6 for BMW R26 and R27, solo REMNANTS	394,87 €	469,90 €
P004C	10185	Crown and pinion wheel set 27:7 for BMW R50-R69S, sidecar original BMW	533,95 €	635,40 €
P004D	3010181	Crown and pinion wheel set 26:6 for BMW R50-R69S, sidecar original BMW	520,00 €	618,80 €
P004E	10160	Crown and pinion wheel set 27:8 for BMW R50S and R69S, solo	474,79 €	565,00 €
P004E	3010172	Crown and pinion wheel set 25:8 for BMW R50-R69S, solo original BMW	515,13 €	613,00 €
P004G	97310	Drive coupling repair (rear drive) for BMW R24-R27 delivered dissected!!!	159,58 €	189,90 €
P004G	9947165	Rivet bolt for wheel spline for BMW R50/5-R75/5 and R50-R69S	1,09 €	1,30 €
P004H	97312	Drive coupling repair (rear drive) for BMW R50-R69S delivered dissected!!!	159,58 €	189,90 €
P004J	97311	Drive coupling (rear drive) for BMW R50-R69S, single to be welded into the crown wheel	125,97 €	149,90 €
P005	3004317	Thread bushing for BMW R50-R69S	7,47 €	8,89 €
P007	03503	Stud bolt drive cover for BMW R25-R27 and R50-R69S stainless steel	3,36 €	4,00 €
P008	22082	Spring washer B 8, DIN137A zincked	0,08 €	0,10 €
P009	22093	Nut M 8 x 1 zincked	0,25 €	0,30 €
P009B	99001	Nut M 8 x 1, fine pitch thread stainless steel	0,97 €	1,15 €
P010	16064	Needle bearing for pinion wheel for BMW R50-R69S	58,74 €	69,90 €
P012	18064	Bearing pinion shaft for BMW R51/2-R69S	29,37 €	34,95 €
P012a	0018064	Bearing pinion shaft for BMW R51/2-R69S reinforced, metal cage	58,74 €	69,90 €
P013	08634	Stud bolt rear drive / swing for BMW R26 and R27	2,10 €	2,50 €
P013A	38248	Distance ring rear drive for BMW R50-R69S	2,10 €	2,50 €
P013B	03530	Stud bolt rear drive / swing for BMW R50-R69S	3,53 €	4,20 €
P014	38252	Threaded connection rear drive for BMW R50-R69S input drive shaft	17,86 €	21,25 €
P015	38257	Radial seal ring, transmission input for BMW R50-R69S	4,58 €	5,45 €
P016	38260	Drive coupling pinion wheel for BMW R50-R69S	83,95 €	99,90 €
P017	38264	Lock plate input pinion gear for BMW R50-R69S	2,94 €	3,50 €
P018	21630	Nut M14 x 1,5 flat for drive shaft for BMW R50-R69S	0,97 €	1,15 €
P018	2163099	Nut M14 x 1,5 flat for wheel axle for BMW R50/5-R100 and R69S (US-version), front and rear zincked	0,97 €	1,15 €
P020	04337	Radial seal ring, drive coupling for BMW R50-R69S, R50/5-R100 and R45/R65	3,61 €	4,30 €
P020	1082	Radial seal ring, drive coupling for BMW R26 and R27	10,00 €	11,90 €
P021A	2064	Bearing crank shaft for BMW R24-R27, front and R24-R25/3, rear and crown wheel outer for BMW R25, R26 and R27	10,42 €	12,40 €
P021B	42738	Needle bearing for crown wheel for BMW R50-R69S	76,89 €	91,50 €
P021C	3038244	Reduction bushing rear drive for BMW R50-R69SR50-R69S in connection with needle bearing R50/5-R75/5	9,20 €	10,95 €
p022a	38931	Thrust ring crown wheel for BMW R50-R69S and R50/5-R100, 1,6mm	19,24 €	22,90 €
p022b	38932	Thrust ring crown wheel for BMW R50-R69S and R50/5-R100, 1,6mm	19,24 €	22,90 €
p022c	32769	Thrust ring crown wheel for BMW R50-R69S and R50/5-R100, 1,7mm	19,24 €	22,90 €
p022d	30527	Thrust ring crown wheel for BMW R50-R69S and R50/5-R100, 1,8mm	19,24 €	22,90 €
p022e	31238	Thrust ring crown wheel for BMW R50-R69S and R50/5-R100, 1,9mm	19,24 €	22,90 €
p022f	30528	Thrust ring crown wheel for BMW R50-R69S and R50/5-R100, 2,0mm	19,24 €	22,90 €
p022g	31239	Thrust ring crown wheel for BMW R50-R69S and R50/5-R100, 2,1mm	33,53 €	39,90 €
p022h	30529	Thrust ring crown wheel for BMW R50-R69S and R50/5-R100, 2,3mm	19,24 €	22,90 €
p022i	30530	Thrust ring crown wheel for BMW R50-R69S and R50/5-R100, 2,2mm	19,83 €	23,60 €
p022j	30531	Thrust ring crown wheel for BMW R50-R69S and R50/5-R100, 2,4mm	20,97 €	24,95 €
p022k	30532	Thrust ring crown wheel for BMW R50-R69S and R50/5-R100, 2,5mm	19,24 €	22,90 €
P023A	12064	Bearing crown wheel for BMW R25-R27	33,53 €	39,90 €
P023B	19064	Bearing crown wheel for BMW R50-R69S and R50-R100	33,53 €	39,90 €
P024a	1230535	Distance washer crown wheel, 2-arm swing, 0,180mm	9,75 €	11,60 €
P024d	1230538	Distance washer crown wheel, 2-arm swing, 0,500mm	8,36 €	9,95 €
P024e	1230539	Distance washer crown wheel, 2-arm swing, 0,630mm	8,36 €	9,95 €
P024f	1230540	Distance washer crown wheel, 2-arm swing, 0,750mm	8,36 €	9,95 €
P024g	1230541	Distance washer crown wheel, 2-arm swing, 0,880mm	8,36 €	9,95 €
P025	13032	Radial seal ring, crown wheel for BMW R25-R27	7,48 €	8,90 €
P025	14032	Radial seal ring, crown wheel for BMW R50-R69S and R50/5-R100	7,65 €	9,10 €
P026	2027	Gasket ring oil drain screw, M14x20x2	0,67 €	0,80 €
P027	07163	Oil drain screw for BMW R24-R69S, M14, magnetic zincked	3,19 €	3,80 €



P027	0007163	Oil drain screw for BMW R24-R69S, M14, magnetic stainless steel	7,48 €	8,90 €
P028A	60102	Brake spanner for BMW R26 and R27, rear used	12,86 €	15,30 €
P028B	60216	Brake spanner for BMW R50-R69S, rear, including nut and washer	16,72 €	19,90 €
P030B	60101	Brake lever for BMW R50-R69S, rear	21,01 €	25,00 €
P032	21615	Nut M10 x 1, flat for brake-key and shockabsorber, rear	0,50 €	0,60 €
P033	6024199	Brake-shoe Set for BMW R50-R69S, rear wheel (Set = 2pc. for 1 rear wheel)	40,67 €	48,40 €
P033	6010301	Brake-shoe Set for BMW R25/3, R26 and R27, NEW (Set = 2pc. for 1 front or rear wheel)	40,67 €	48,40 €
P034A	2051	Brake lining for BMW R25/3, R26 and R27	10,00 €	11,90 €
P034B	1051	Brake lining for BMW R50-R69S	10,00 €	11,90 €
P035A	0098051	Rivet bolts brake lining for BMW R24-R27, 50 pcs., 8mm long	3,36 €	4,00 €
P035B	0008051	Rivet bolts brake lining for BMW R51/2-R69S, 50 pcs., 10mm long	3,36 €	4,00 €
P037A	60134	Brake-shoe spring for BMW R25-R27	2,48 €	2,95 €
P037B	60237	Brake-shoe spring for BMW R51/3-R69S, front and rear lower	2,73 €	3,25 €
P038A	38034	Drive shaft for BMW R50-R60/2 and R69S, reinforced, cone 1:6	220,00 €	261,80 €
P038B	38035	Drive shaft for BMW R50-R69S overhaul - PLEASE INDICATE CONUS SIZE!!!	220,00 €	261,80 €
P038B	3034	Repair of universal joint, labour and u-joint	76,64 €	91,20 €
P038C	99921	U-joint for BMW R51/2-R68, R50-R69S and R50/5-R100 (all models)	38,32 €	45,60 €
P039	98432	Lock washer A 8, Form B zincked	0,08 €	0,10 €
P040	30414	Drive shaft, twelve-sided bolt for BMW R50-R69S and R50/5-R100RT until year of manufacture 09/1980	1,64 €	1,95 €
P040	1242297	Drive shaft, twelve-sided bolt for BMW R45, R65 and R80/7-R100RT from year of manufacture 09/1980	1,93 €	2,30 €
P041	90016	Rubber boot gearbox-swingarm for BMW R50-R69S	10,29 €	12,25 €
P042	191191	Clamp gearbox boot for BMW R50-R69S, rear (clamp with screw)	1,30 €	1,55 €
P042	9952070	Clamp gearbox boot for BMW R50-R69S, rear solid measure: Ø=70,0mm, original shape	3,15 €	3,75 €
P042	9952090	Clamp gearbox boot for BMW R50-R69S, front solid measure: Ø=90,0mm, original shape	4,12 €	4,90 €
P043	191192	Clamp gearbox boot for BMW R50-R69S, front (clamp with screw)	1,60 €	1,90 €
P044A	138238	Drive shaft bell for BMW R50-R69S used - PLEASE INDICATE CONUS SIZE!!!	38,35 €	45,64 €
P044B	038237	Drive shaft bell for BMW R 50-R69S, 1:5 cone, M14	82,77 €	98,50 €
P044C	38238	Drive shaft bell for BMW R 50-R69S, 1:6 cone, M16	73,19 €	87,10 €
P046A	21630	Nut M14 x 1,5 flat for drive shaft for BMW R50-R69S	0,97 €	1,15 €
P046A	2163099	Nut M14 x 1,5 flat for wheel axle for BMW R50/5-R100 and R69S (US-version), front and rear zincked	0,97 €	1,15 €
P046B	30084	Drive shaft nut, M16 with bund	6,47 €	7,70 €
P047A	26031	Swingarm for BMW R26 and R27, rear used	100,00 €	119,00 €
P047B	27031	Swingarm for BMW R50-R60/2 and R69S, rear used	247,90 €	295,00 €
P047D	54260	Converted swingarm, /5 transmission in old frame in exchange	294,12 €	350,00 €
P047D	31687	Suspension unit holder for BMW /5 „swing arm conversion-type“	62,94 €	74,90 €
P048	39812	Grease stop washer swingarm for BMW R26, R27 and R50-R100, rear	4,62 €	5,50 €
P049	13064	Wheel bearing for BMW R26, R27, R50/5-R100 and R45/R65 until year of manufacture 09/1984 and rocker arm for BMW R26, R27, R50-R69S and R50/5-R100, front and rear	15,88 €	18,90 €
P049	0013064	Wheel bearing for BMW R26, R27 and R50/5-R100, +0,10 overmeasure and rocker arm for BMW R26, R27 and R50-R69S, front and rear	35,88 €	42,70 €
P049	0013065	Wheel bearing for BMW R26, R27 and R50/5-R100, +0,15 overmeasure and rocker arm for BMW R26, R27 and R50-R69S, front and rear	39,41 €	46,90 €
P050	00324	Thrust sleeve swingarm for BMW R26-R100	5,84 €	6,95 €
P051	00331	Radial seal ring, swingarm for BMW R26, R27, R50-R69S and R50/5-R100 until 09/1980	3,19 €	3,80 €
P052	54171	Bolt swingarm for BMW R26, R27 and R50-R69S with nut and internal hexagon	16,39 €	19,50 €
P053	54174	Nut for rear swing arm bolt for BMW R26, R27, R50-R69S and R50/5-R100	4,83 €	5,75 €
P054	54172	Aluminium cap for rear swing arm bearing for BMW R26-R69S	12,77 €	15,20 €
P055	54266	Gasket driveshaft for BMW R50-R69S	1,09 €	1,30 €
P058	63073	Gasket ring toolbox screw, M10x14x1.5	0,21 €	0,25 €
P059B	19216	Oil drain screw for BMW R50-R69S, M10 x 1 brass	2,14 €	2,55 €
P059B	19217	Oil drain screw for BMW R50-R69S, M10 x 1 stainless steel	4,16 €	4,95 €
P060	04158	Wheel axle for BMW R26 and R27, rear zincked	50,34 €	59,90 €
P060B	04368	Wheel axle for BMW R50-R69S, rear	50,34 €	59,90 €
P060C	3004368	Wheel axle for BMW R50-R69S, rear stainless steel	55,29 €	65,80 €
P061	04378	Washer for wheel axle for BMW R24-R69S cined	0,38 €	0,45 €
P061	31089	Washer for wheel axle for BMW R24-R69S stainless steel polished	4,86 €	5,78 €
P062A	22155	Nut M14 x 1,5 for wheel axle for BMW R24-R69S zincked	0,76 €	0,90 €
P062B	98388	Nut M14 x 1,5 for wheel axle for BMW R24-R69S stainlees steel	1,93 €	2,30 €
P063	54176	Axle bolt for BMW R26-R69S, rear original BMW	13,95 €	16,60 €
P063A	995176	Axle bolt for BMW R26-R69S, rear zincked	7,39 €	8,79 €
P065	98365	Nut M10 x 1, fine pitch thread stainless steel	1,26 €	1,50 €
P066	54182	Shock absorber mounting for BMW R26 and R27, rear, right side used	12,93 €	15,39 €
P066	5418201	Shock absorber mounting for BMW R26 and R27, rear, left side used	12,93 €	15,39 €



P066B	54283	Shock absorber mounting for BMW R50-R69S, rear used	23,01 €	27,38 €
P066C	3054282	Shock absorber mounting for BMW R50-R69S, rear, left side	43,11 €	51,30 €
P066D	3054283	Shock absorber mounting for BMW R50-R69S, rear, right side	43,11 €	51,30 €
P067A	54284	Spring for BMW R26, R27 and R50-R69S, rear suspension for solo use	14,37 €	17,10 €
P067B	2018	Spring for BMW R26, R27 and R50-R69S, rear suspension for sidecar use	14,12 €	16,80 €
P068	54290	Shock absorber for BMW R26, R27 and R50-R69S, rear, BOGE REMNANTS	113,36 €	134,90 €
P068	3054091	Shock absorber for BMW R26 and R27, rear	80,00 €	95,20 €
P068A	3054290	Shock absorber for BMW R50-R69S, rear	80,00 €	95,20 €
P070A	46016	Silent block for BMW R26, R27 and R50-R69S, small	3,49 €	4,15 €
P070B	89016	Silent block for BMW R50-R69S, big, rear	5,80 €	6,90 €
P071A	54194	Rear suspension adjusting-jacket for BMW R26, R27 and R50-R69S	30,88 €	36,75 €
P071B	54195	Rear suspension adjusting-jacket for BMW R26, R27 and R50-R69S used	15,34 €	18,25 €
P072	8077	Shock cover for BMW R26-R69S, rear lower aluminium	13,28 €	15,80 €
P073	54528	Stop rubber for shock absorber for BMW R26, R27 and R50-R69S, front and rear	1,93 €	2,30 €
P074	54201	Stop plate for shock absorber for BMW R26-R69S, rear	10,59 €	12,60 €
P075	54204	Shock absorber compensation rubber for BMW R26, R27 and R50-R69S	1,93 €	2,30 €
P076	54208	Shock absorber rubber bearing for BMW R26, R27 and R50-R69S, rear upper	1,93 €	2,30 €
P077	054210	Shock absorber cap for rubber bearing for BMW R26, R27 and R50-R69S	2,69 €	3,20 €
P078	21615	Nut M10 x 1, flat for brake-key and shockabsorber, rear	0,50 €	0,60 €
P078	22122	Nut M10 x 1 zincked	0,34 €	0,40 €
P079	54044	Aluminium cap for rear suspension BMW R26-R69S	14,83 €	17,65 €
P080	14625	Suspension unit locking screw for BMW R50-R69S, rear, left side stainless steel	7,65 €	9,10 €
P081	98424	Washer M13, DIN125 cined	0,17 €	0,20 €
P081	98425	Washer M13, DIN125/A2 stainless steel	0,42 €	0,50 €
P082A	98375	Nut M12 x 1,5 zincked	0,67 €	0,80 €
P082B	98377	Nut M12 x 1,5, flat stainless steel	2,10 €	2,50 €
P082B	98378	Nut M12 x 1,5 stainless steel	2,44 €	2,90 €
P083C	54226	Suspension unit locking screw for BMW R26 and R27, rear, right side stainless steel	10,00 €	11,90 €
P083CC	3054225	Suspension unit locking screw for BMW R26 and R27, rear, right side original BMW New old stock, REMNANTS	10,00 €	11,90 €
P083D	54270	Suspension unit locking screw for BMW R50-R69S, rear, right side stainless steel	8,32 €	9,90 €
P083DE	5427099	Suspension unit locking screw for BMW R50-R69S, rear, right side	6,72 €	8,00 €
P091	038126	Washer drive shaft flange for BMW R26 and R27, 1,0mm also as washer for ignition lock for BMW /6 and up	1,81 €	2,15 €
P091	038127	Washer M18 for castle nut drive shaft flange for BMW R26 and R27	0,46 €	0,55 €
P091a	038129	Washer drive shaft flange for BMW R26 and R27, 2,0mm	1,81 €	2,15 €
P092	38186	Flange drive shaft for BMW R26 and R27 used	28,15 €	33,50 €
P092	3038200	Drive shaft for BMW R26 and R27, complete with pinion wheel coupling NEW	176,47 €	210,00 €
P093	38122	Spring washer for drive shaft nut for BMW R26 and R27	0,43 €	0,51 €
P094	38120	Castle nut drive flange M18 for BMW R26 and R27	8,36 €	9,95 €
P095	27016	Driving plate for BMW R26 and R27	16,39 €	19,50 €
P096	38105	Lock washer driving plate for BMW R24-R27 and R51/2-R68	4,03 €	4,80 €
P097	38179	Driving plate chrome ring for BMW R24-R27 and R51/2-R68	14,83 €	17,65 €
P098	38104	Spacer ring driving plate for BMW R26-R27	1,85 €	2,20 €
P099	9077	Hubcap for BMW R26 and R27, small silver painted	9,41 €	11,20 €
P099A	60171	Hubcap for BMW R26 and R27, small chromed	12,52 €	14,90 €
P100A	13346	Suspension unit locking screw for BMW R26, R27 and R50-R69S, front, upper and for BMW R26 and R27, lower and rear left side, chromed	5,00 €	5,95 €
P100B	14337	Suspension unit locking screw for BMW R26 and R27, rear, left side stainless steel	6,89 €	8,20 €
P100B	14345	Suspension unit locking screw for BMW R26, R27 and R50-R69S, front, upper and for BMW R26 and R27, lower, stainless steel	6,64 €	7,90 €
P101	22083	Spring washer B10, DIN137A zincked	0,17 €	0,20 €
P102	17064	Bearing pinion shaft (roller bearing) for BMW R26 and R27	44,12 €	52,50 €
P107	82460	Bearing pinion shaft for BMW R24-R27	28,07 €	33,40 €
P108	30130	Threaded connection rear drive for BMW R26 and R27	17,90 €	21,30 €
P109	30541	Radial seal ring, transmission input for BMW R26 and R27	4,58 €	5,45 €
P110	38159	Cap nut for drive shaft for BMW R26 and R27	23,53 €	28,00 €
P111	38163	Spacer rubber for gear pinion/drive shaft for BMW R26 and R27	4,12 €	4,90 €
P112	38146	Drive coupling pinion wheel for BMW R26 and R27 NEW	38,11 €	45,35 €
P113	38144	Washer drive shaft nut for BMW R25, R26 and R27	0,38 €	0,45 €
P114	38142	Drive shaft nut for BMW R25-R27	4,03 €	4,80 €
P115	36226	Split pin 2,0 x 32	0,13 €	0,15 €
P115a	44136	Split pin for brake rod stainless steel	0,13 €	0,15 €
P000	600019	Gasket set rear drive (No.A03), for BMW R26-R28	-37,31 €	-44,40 €



Group T: Fork and steering R24, R25, R25/2

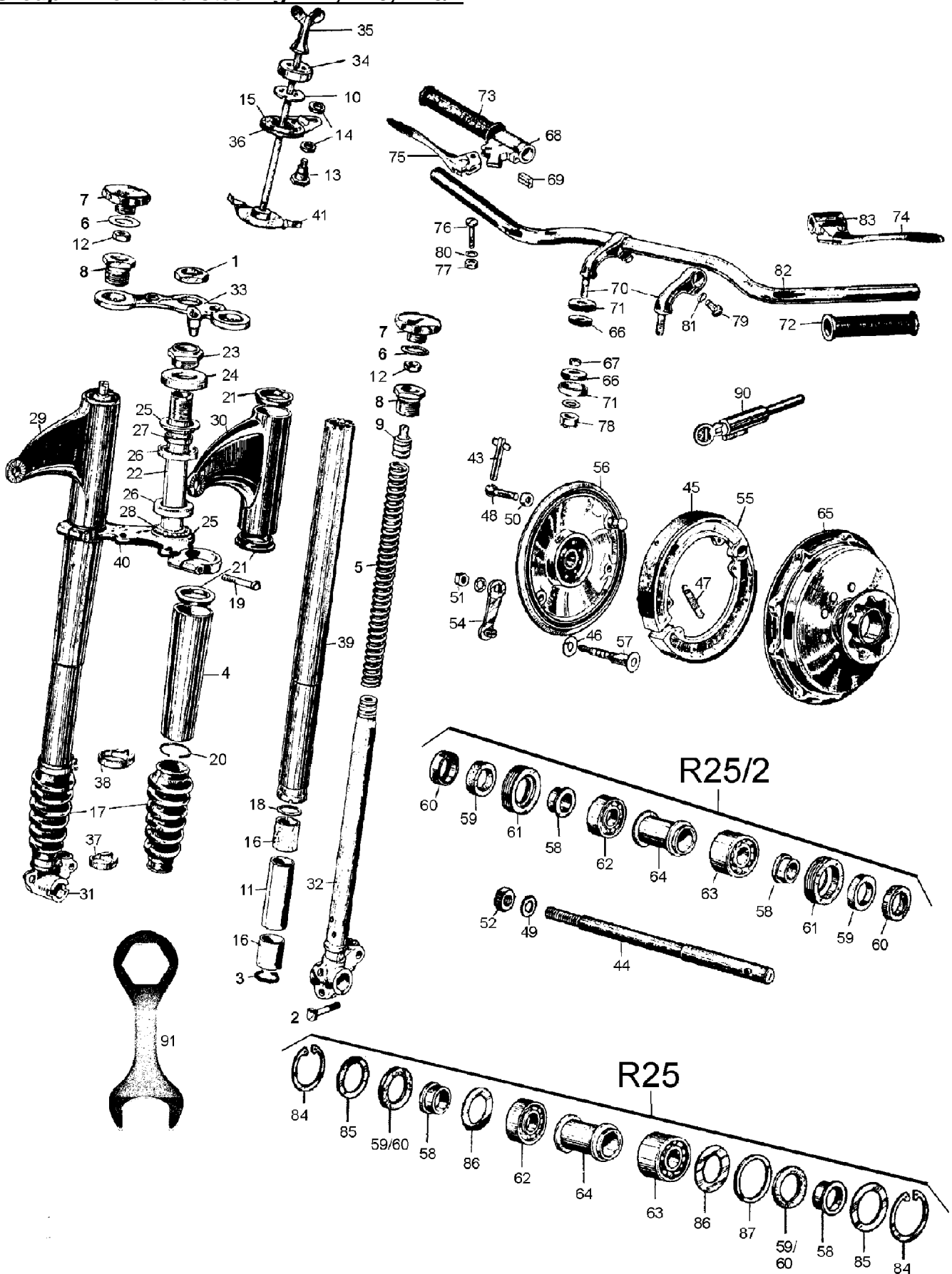

Picture-No.	Article-No.	Description	Net	Gross
T00	8080165	Guide plate cable holder for BMW R25/2 and R51/3-R68 mount on lower fork yoke	15,93 €	18,96 €
T000	97003	Wrench wheel bearing retainert nut for BMW R25-R27	24,12 €	28,70 €
T001	00101	Counter nut, fork bridge for BMW R25-R69S	6,22 €	7,40 €
T002	54262	Axle bolt for BMW R25-R25/2 and R51/3-R68, front stainless steel, precision-turned	16,89 €	20,10 €
T003	00128	Lock ring fork bushing for BMW R24, R25 and R25/2	0,67 €	0,80 €



T004	02100	Fork jacket for BMW R25 and R25/2, top black painted, NEW	26,22 €	31,20 €
T005	2054002	Fork spring for BMW R25 and R25/2	20,00 €	23,80 €
T006	33343	Gasket ring fork for BMW R25, R25/2 and from R50/5, upper cap	1,43 €	1,70 €
T007	00241	Aluminium cap for fork for BMW R25 und R25/2	16,39 €	19,50 €
T008	00156	Fork mounting piece for BMW R25 and R25/2 used	9,20 €	10,95 €
T009	9054127	Holder for suspension spring R24, R25 and R25/2, front top, used	9,20 €	10,95 €
T010	00245	Steering damper lock washer for BMW R25-R69S	8,78 €	10,45 €
T013	00253	Steering damper bolt for BMW R25, R25/2 and R25/3	4,60 €	5,47 €
T014	00257	Rubber ring for steering damper bolt for BMW R25-R69S	1,64 €	1,95 €
T015	7051	Steering damper friction plate for BMW R24-R69S	2,86 €	3,40 €
T016	00148	Bushing fork for BMW R24, R25 and R25/2	9,16 €	10,90 €
T017	00261	Rubber boot fork for BMW R24, R25 and R25/2	11,26 €	13,40 €
T018	2000151	Washer for bushing front fork for BMW R25 and R25/2	3,78 €	4,50 €
T019	00160	Fork pinch bolt for BMW R25, R25/2 and R25/3 stainless steel	12,86 €	15,30 €
T021	00166	Fork rubber ring for BMW R24, R25 and R25/2	1,85 €	2,20 €
T023	00182	Steering adjusting nut for BMW R24-R69S	8,32 €	9,90 €
T024	00184	Dust cap steering head for BMW R25-R69S	6,30 €	7,50 €
T028	3025	Steering head bearing set for BMW R25-R69S, tapered	40,34 €	48,00 €
T028a	5590040	Ballbearing set steering head for BMW R24-R69S true to original	40,34 €	48,00 €
T031	00208	Fork sliding tube for BMW R25 and R25/2, right side used	29,41 €	35,00 €
T032	21031	Fork sliding tube for BMW R25 and R25/2, left side used	29,41 €	35,00 €
T033	00141	Top fork yoke for BMW R25 and R25/2 used	23,28 €	27,70 €
T034	00114	Steering damper cap for BMW R25-R27 and R51/3-R69S chromed	14,20 €	16,90 €
T035	00045	Steering damper knob for BMW R25-R25/3 and R51/3-R68	32,69 €	38,90 €
T036	00219	Steering damper resistance plate for BMW R25, R25/2 and R25/3	15,13 €	18,00 €
T037	00175	Clamp fork boot for BMW R25 and R25/2, bottom (clamp with screw)	1,26 €	1,50 €
T038	00173	Clamp fork boot for BMW R25 and R25/2, top (clamp with screw)	1,60 €	1,90 €
T038	9000173	Clamp air filter rubber for BMW R25/3, R26 and R27 (clamp with screw)	1,51 €	1,80 €
T039	00223	Fork tube for BMW R25 and R25/2, left/right used	28,15 €	33,50 €
T040	00213	Lower fork yoke for BMW R25 and R25/2 used	51,13 €	60,84 €
T041	00230	Pressure plate steering damper for BMW R25, R25/2 and R25/3	18,95 €	22,55 €
T043	10055	Brake cable adjusting screw brass	8,91 €	10,60 €
T044	60126	Wheel axle for BMW R25 and R25/2, front	50,34 €	59,90 €
T044	2060125	Wheel axle for BMW R20, R23 and R24, front, Left-hand-thread New old stock with storage traces	50,34 €	59,90 €
T045A	4051	Brake lining for BMW R25 and R 25/2	10,00 €	11,90 €
T045B	0098051	Rivet bolts brake lining for BMW R24-R27, 50 pcs., 8mm long	3,36 €	4,00 €
T047	60134	Brake-shoe spring for BMW R25-R27	2,48 €	2,95 €
T047b	60133	Brake-shoe spring for BMW R20-R24, front	4,79 €	5,70 €
T048	60141	Brake cable holder for BMW R25-R25/2 and R51/3-	2,44 €	2,90 €
T049	31089	Washer for wheel axle for BMW R24-R69S stainless steel polished	4,86 €	5,78 €
T051	22094	Nut M 8 x 1, flat for brake key	0,29 €	0,35 €
T052	98388	Nut M14 x 1,5 for wheel axle for BMW R24-R69S stainless steel	1,93 €	2,30 €
T054	60109	Brake lever for BMW R25 und R25/2, front used	19,24 €	22,90 €
T055A	6010024	Brake-shoe Set for BMW R24, rear, rebuilt	95,00 €	113,05 €
T055A	6010124	Brake-shoe for BMW R24 in exchange (old brake shoes must be send to us)	20,17 €	24,00 €
T055B	60100	Brake-shoe for BMW R25 and R25/2, rebuilt	29,33 €	34,90 €
T056	77031	Brake anchor plate for BMW R25-R25/2, WITHOUT attachment parts used	43,70 €	52,00 €
T057	60106	Brake spanner for BMW R25-R25/2, front used	12,86 €	15,30 €
T058B	038142	Thrust sleeve for BMW R25, R25/2 and R25/3 right/left side and for BMW R26, R27, right side	5,84 €	6,95 €
T059	38155	Felt ring for wheel bearing for BMW R25/2-R27 and R50/5-R75/5	2,23 €	2,65 €
T060	38157	Felt ring cap wheel bearing for BMW R25/2-R27 and R50/5-R75/5	2,94 €	3,50 €
T061	38160	Wheel bearing retainer for BMW R25/2 and R25/3, for ball bearing	20,97 €	24,95 €
T062	6203	Bearing cam shaft R24-R69S, crankshaft R51/3-R69S, front end, with 17mm cone wheel bearing R25-R25/2, pinion shaft R24, auxiliary shaft /5 4-gear box, crankshaft most front R51/3-R69	6,22 €	7,40 €
T063	15064	Bearing auxiliary shaft for BMW R24-R27 and R50-R69S, front front/rear wheel R25-R25/3	22,65 €	26,95 €
T064	38126	Spacer sleeve wheel bearing for BMW R25 and R25/2, inner	14,62 €	17,40 €
T065	38007	Wheel hub for BMW R25 and R25/2 used	142,02 €	169,00 €
T066	72193	Handlebar mounting rubber for BMW R24, R25 and R25/2	1,93 €	2,30 €
T068A	72164	Throttle control unit complete for BMW R25, R25/2 and R25/3	87,94 €	104,65 €
T068AA	0110020	Throttle control unit for BMW R24 with slotted handlebar, complete	33,53 €	39,90 €
T068B	7216601	Throttle control housing for BMW R25, R25/2 and 25/3	60,42 €	71,90 €
T068C	72165	Throttle control cover for BMW R25, R25/2 und R25/3 Holding holes may need to be adjusted !	12,77 €	15,20 €
T069	72163	Throttle control sliding block for BMW R25, R25/2 and R25/3	12,77 €	15,20 €



T070A	72280	Handlebar riser for BMW R25 and R25/2 with stainless steel screw stainless steel chromed	75,00 €	89,25 €
T071	72190	Handlebar riser cap for BMW R25 and R25/2	6,72 €	8,00 €
T072	30407	Handle bar rubber for BMW R24-R90S, in-house production, round, left side	4,62 €	5,50 €
T072	30868	Handle bar rubber for BMW R24-R90S, in-house production, round, right side	4,62 €	5,50 €
T072a	19152	Handle bar rubber for BMW R24-R90S, in-house production, round, pair	8,82 €	10,50 €
T072b	720850	Handle bar rubber for BMW R24-R90S, Magura, round, pair	16,72 €	19,90 €
T073	72167	Throttle twist tube for BMW R25-R25/3 and R51/3-R68	18,07 €	21,50 €
T074	72109	Clutch lever for BMW R25-R25/3 and R51/3-R68	12,86 €	15,30 €
T075	72132	Brake lever for BMW R25-R25/3 and R51/3-R68	12,86 €	15,30 €
T076	30870	Clutch/brake lever bolt, early version, for BMW R25-R69S	2,23 €	2,65 €
T076A	22174	Clutch/brake lever bolt for BMW R25-R69S stainless steel, polished	8,32 €	9,90 €
T078	23422	Castle nut M10x1 zined	0,97 €	1,15 €
T079	14020	Screw for handlebar riser for BMW R25 and R25/2 stainless steel polished	6,22 €	7,40 €
T082	72001	Handlebar for BMW R24 with slot (EMW R35/2, R35/3)	41,93 €	49,90 €
T082A	72027	Handlebar for BMW R25/2 and R25/3, original shape	30,17 €	35,90 €
T082C	94052	Handlebar for side car use, universal, flat 750mm wide, Fehling	41,51 €	49,40 €
T082C	4052	Handlebar for side car use for BMW R26, R27 and R50-R69S, original shape	29,58 €	35,20 €
T082D	72002	Handlebar (touring) medium high 95mm high, 670mm wide	27,73 €	33,00 €
T082E	5052	Handlebar half-high, similar to BMW R50/5, R60/5 and R75/5 145mm high, 765mm wide, Fehling, US-Version	48,82 €	58,10 €
T083	72112	Clutch control unit for BMW R25-R25/3 and R51/3-R68, complete	48,74 €	58,00 €
T083A	0072112	Clutch control housing for BMW R25, R25/2, R25/3 and R51/2-R68	29,41 €	35,00 €
T090	1025	Steering lock for BMW R25, R25/2 and R51/2-R68, long	16,30 €	19,40 €
T091	41036	Tool-wrench 36/41, vehicle tool kit for BMW R24-R69S	11,26 €	13,40 €
T100	22031	Fork for BMW R24, R25 and R25/2, without head light ears used	420,17 €	500,00 €
T501	38109	Spoke for BMW R24, M3,5 x 220, long, front and rear chromed, with nippel	1,18 €	1,40 €
T501	38107	Spoke for BMW R24, M3,5 x 165, short, rear chromed, cropped, with nippel	1,60 €	1,90 €
T501	0038107	Spoke for BMW R24, M3,5 x 173, short, front chromed, cropped, with nippel	1,26 €	1,50 €
T501AA	038105	Spoke 18" side car, M3,5 x 200 with nippel	1,60 €	1,90 €
T503	3044	Spoke for BMW R25 and R25/2, M3,5 x 154, short chromed, with nippel	1,09 €	1,30 €
T503	2044	Spoke for BMW R25 and R25/2, M3,5 x 210, long chromed, with nippel	1,09 €	1,30 €
T503A	34592	Spoke for BMW R50/5-R60/6, M4 x 153, front, drum chromed, with nippel, also for BMW GS from year of manufacture 1988, rear	1,01 €	1,20 €
T999	4038114	Rim for BMW R25 and R25/2 stainless steel polished with special nipples	142,77 €	169,90 €
T999	8070110	Grommet guide plate for BMW R25/2, R25/3 and R51/3-R68	2,94 €	3,50 €



Group Q: Fork and steering R25/3

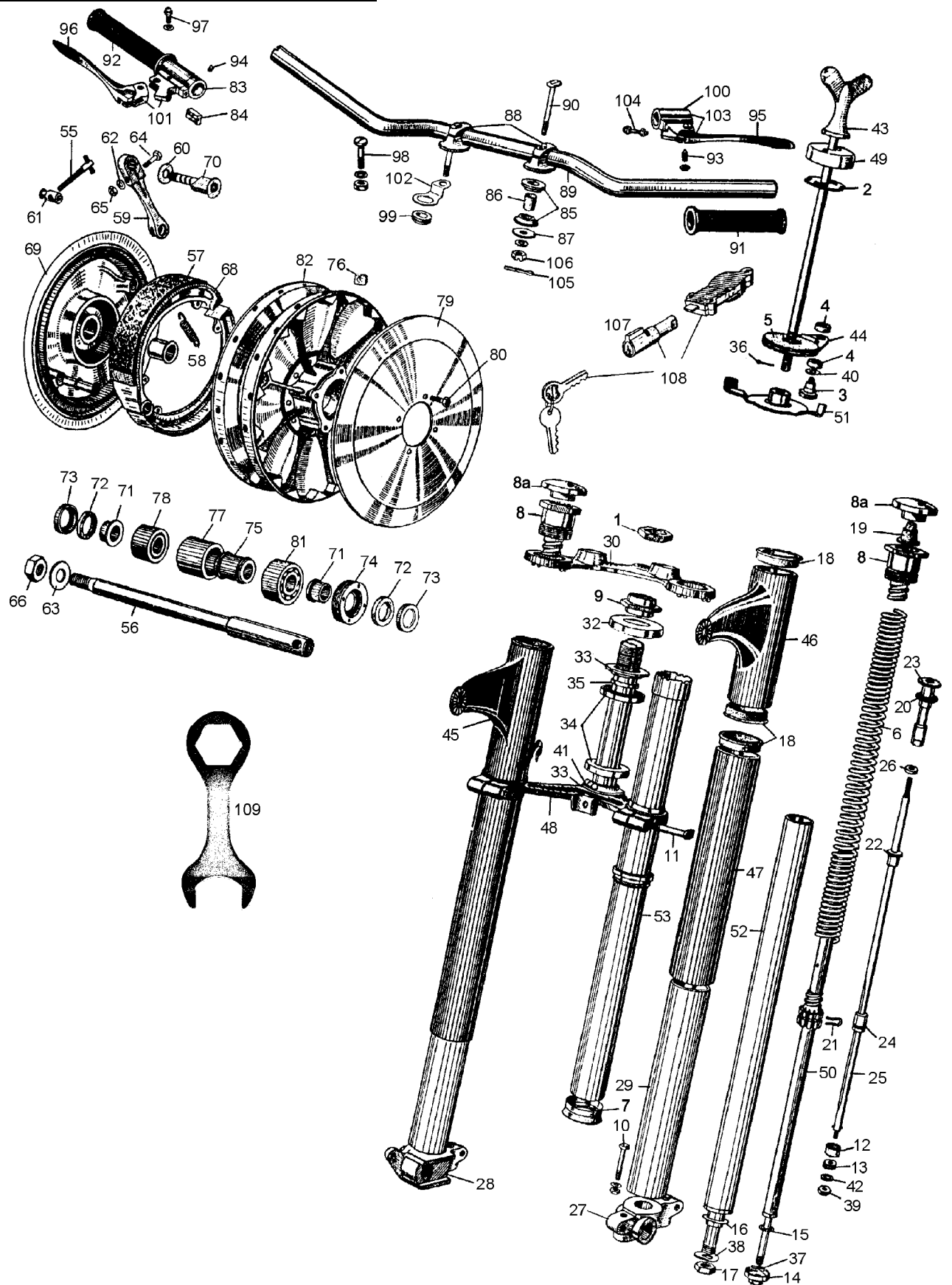

<u>Picture-No.</u>	<u>Article-No.</u>	<u>Description</u>	<u>Net</u>	<u>Gross</u>
Q0	22174	Clutch/brake lever bolt for BMW R25-R69S stainless steel, polished	8,32 €	9,90 €
Q0	0098051	Rivet bolts brake lining for BMW R24-R27, 50 pcs., 8mm long	3,36 €	4,00 €
Q000	97003	Wrench wheel bearing retainert nut for BMW R25-R27	24,12 €	28,70 €
Q001	00101	Counter nut, fork bridge for BMW R25-R69S	6,22 €	7,40 €
Q002	00245	Steering damper lock washer for BMW R25-R69S	8,78 €	10,45 €
Q003	00253	Steering damper bolt for BMW R25, R25/2 and R25/3	4,60 €	5,47 €



Q004	00257	Rubber ring for steering damper bolt for BMW R25-R69S	1,64 €	1,95 €
Q005	7051	Steering damper friction plate for BMW R24-R69S	2,86 €	3,40 €
Q006	54002	Fork spring for BMW R25/3	24,79 €	29,50 €
Q007	00285	Radial seal ring, fork for BMW R25/3	9,20 €	10,95 €
Q008	54128	Fork mounting piece for BMW R25/3	36,89 €	43,90 €
Q008A	48044	Aluminium cap for fork for BMW R25/3	16,30 €	19,40 €
Q009	00182	Steering adjusting nut for BMW R24-R69S	8,32 €	9,90 €
Q010	00107	Axle bolt for BMW R25/3, front stainless steel	12,94 €	15,40 €
Q011	00160	Fork pinch bolt for BMW R25, R25/2 and R25/3 stainless steel	12,86 €	15,30 €
Q014	00290	Fork end lock nut for BMW R25/3	8,00 €	9,52 €
Q015	54140	Gasket ring fork BMW R25/3, R51/2-R68 and R50/5-R75/5 for shock tube, low	0,42 €	0,50 €
Q016	54144	Gasket washer sliding tube for BMW R25/3	1,09 €	1,30 €
Q017	2054148	Nut for lower fork end for BMW R25/3	2,48 €	2,95 €
Q018	00165	Fork rubber ring for BMW R25/3	1,85 €	2,20 €
Q019	54152	Fork stop rubber for BMW R25/3	9,20 €	10,95 €
Q020	2054156	Rubber washer fork for BMW R25/3	1,51 €	1,80 €
Q021	2054160	Clamp spring, damper tube, fork for BMW 25/3 and R51/3-R68	6,05 €	7,20 €
Q023	54168	Thrust piece fork damper for BMW R25/3 used	2,97 €	3,53 €
Q027	00282	Fork end for BMW R25/3, left side used	17,90 €	21,30 €
Q028	00278	Brake holder for BMW R25/3 used	31,93 €	38,00 €
Q029	92032	Fork jacket for BMW R25/3, lower chromed	52,10 €	62,00 €
Q030	00139	Top fork yoke for BMW R25/3 used	33,53 €	39,90 €
Q032	00184	Dust cap steering head for BMW R25-R69S	6,30 €	7,50 €
Q034	3025	Steering head bearing set for BMW R25-R69S, tapered	40,34 €	48,00 €
Q034a	5590040	Ballbearing set steering head for BMW R24-R69S true to original	40,34 €	48,00 €
Q036	45055	Split pin for clutch lever for BMW R25, R25/2 and R25/3	0,08 €	0,10 €
Q038	98462	Spring washer B16, DIN137 zincked	0,34 €	0,40 €
Q039	98310	Nut M 5 zincked	0,08 €	0,10 €
Q040	31851	Washer steering damper bolt for BMW R25-R69S	0,42 €	0,50 €
Q043	00045	Steering damper knob for BMW R25-R25/3 and R51/3-R68	32,69 €	38,90 €
Q044	00219	Steering damper resistance plate for BMW R25, R25/2 and R25/3	15,13 €	18,00 €
Q045	00199	Headlight ear for BMW R25/2 and R25/3, NEW, right side black painted	41,93 €	49,90 €
Q046	00206	Headlight ear for BMW R25/2 and R25/3, NEW, left side black painted	41,93 €	49,90 €
Q047	02111	Fork jacket for BMW R25/3, upper, black	31,93 €	38,00 €
Q048	00214	Lower fork yoke for BMW R25/3 used	51,13 €	60,84 €
Q049	00114	Steering damper cap for BMW R25-R27 and R51/3-R69S chromed	14,20 €	16,90 €
Q050	54184	Fork damper unit for BMW R25/3 used	63,03 €	75,00 €
Q051	00230	Pressure plate steering damper for BMW R25, R25/2 and R25/3	18,95 €	22,55 €
Q052	72031	Fork sliding tube for BMW R25/3 used - Please indicate which side (left or right) is needed!	65,55 €	78,00 €
Q053	20031	Fork tube for BMW R25/3 used	30,67 €	36,50 €
Q055	10055	Brake cable adjusting screw brass	8,91 €	10,60 €
Q056	60127	Wheel axle for BMW R25/3, front	50,34 €	59,90 €
Q057a	2051	Brake lining for BMW R25/3, R26 and R27	10,00 €	11,90 €
Q058	60134	Brake-shoe spring for BMW R25-R27	2,48 €	2,95 €
Q058	60239	Brake-shoe spring for BMW R51/3-R69S, front upper	2,48 €	2,95 €
Q059	60111	Brake lever for BMW R25/3, R26 and R27, front used	19,24 €	22,90 €
Q061	60143	Brake cable bolt WITH thread for BMW R25/3-R27 and R51/3-R68 DUPLEX, upper	3,19 €	3,80 €
Q063	04378	Washer for wheel axle for BMW R24-R69S cinced	0,38 €	0,45 €
Q063	31089	Washer for wheel axle for BMW R24-R69S stainless steel polished	4,86 €	5,78 €
Q064	98159	Screw M 6 x 30, hexagon with shaft	0,15 €	0,18 €
Q065	98323	Nut M 6 zincked	0,13 €	0,15 €
Q066	22155	Nut M14 x 1,5 for wheel axle for BMW R24-R69S zincked	0,76 €	0,90 €
Q068	6010301	Brake-shoe Set for BMW R25/3, R26 and R27, NEW (Set = 2pc. for 1 front or rear wheel)	40,67 €	48,40 €
Q069	79031	Brake anchor plate for BMW R25/3, WITHOUT attachment parts used	75,63 €	90,00 €
Q070	60104	Brake spanner for BMW R25/3, R26 and R27, front used	12,86 €	15,30 €
Q071	038142	Thrust sleeve for BMW R25, R25/2 and R25/3 right/left side and for BMW R26, R27, right side	5,84 €	6,95 €
Q072	38155	Felt ring for wheel bearing for BMW R25/2-R27 and R50/5-R75/5	2,23 €	2,65 €
Q073	38157	Felt ring cap wheel bearing for BMW R25/2-R27 and R50/5-R75/5	2,94 €	3,50 €
Q074	38160	Wheel bearing retainer for BMW R25/2 and R25/3, for ball bearing	20,97 €	24,95 €
Q075	38128	Spacer pipe wheel bearing for BMW R25/3, inner for ball bearing / needle bearing	13,19 €	15,70 €
Q076	15001	Spoke adaptor square	1,22 €	1,45 €
Q077	38130	Distance sleeve wheel bearing for BMW R25/3, outside for ball bearing/needle bearing	10,50 €	12,50 €
Q078	2065	Wheel bearing for BMW R25/3	23,95 €	28,50 €



Q079A	91004	Hubcap for BMW R25/3 chromed	17,23 €	20,50 €
Q079B	91005	Hubcap for BMW R25/3 silver painted	12,52 €	14,90 €
Q080	38181	Screw for hub-cap for BMW R25/3-R68, M 6 chromed, wrench size 9mm	2,10 €	2,50 €
Q081	15064	Bearing auxiliary shaft for BMW R24-R27 and R50-R69S, front front/rear wheel R25-R25/3	22,65 €	26,95 €
Q082	030010	Wheel hub for BMW R25/3 with new bearings and power blasted	178,95 €	212,95 €
Q082	38030	Wheel hub for BMW R25/3, R26 and R27 used, WITHOUT bearings/bushings/spacers/bearing seat	41,93 €	49,90 €
Q082B	88090	Wheel bearing carrier for BMW R25/3, R26 and R27	45,50 €	54,15 €
Q083	72165	Throttle control cover for BMW R25, R25/2 und R25/3 Holding holes may need to be adjusted !	12,77 €	15,20 €
Q083A	7216601	Throttle control housing for BMW R25, R25/2 and 25/3	60,42 €	71,90 €
Q083A	72167	Throttle twist tube for BMW R25-R25/3 and R51/3-R68	18,07 €	21,50 €
Q084	72163	Throttle control sliding block for BMW R25, R25/2 and R25/3	12,77 €	15,20 €
Q085	72194	Handlebar mounting rubber for BMW R25/3 and R26	2,35 €	2,80 €
Q086	72147	Distance sleeve for handlebar for BMW R25/3 and R26	3,57 €	4,25 €
Q088	72104	Handlebar riser for BMW R25/3, R26 and R27 stainless steel chromed	38,36 €	45,65 €
Q089A	72027	Handlebar for BMW R25/2 and R25/3, original shape	30,17 €	35,90 €
Q089C	94052	Handlebar for side car use, universal, flat 750mm wide, Fehling	41,51 €	49,40 €
Q089C	4052	Handlebar for side car use for BMW R26, R27 and R50-R69S, original shape	29,58 €	35,20 €
Q089D	5052	Handlebar half-high, similar to BMW R50/5, R60/5 and R75/5 145mm high, 765mm wide, Fehling, US-Version	48,82 €	58,10 €
Q089E	72002	Handlebar (touring) medium high 95mm high, 670mm wide	27,73 €	33,00 €
Q090	72145	Screw for handlebar riser for BMW R25/3 and R26 chromed	9,03 €	10,75 €
Q091	30407	Handle bar rubber for BMW R24-R90S, in-house production, round, left side	4,62 €	5,50 €
Q091	30868	Handle bar rubber for BMW R24-R90S, in-house production, round, right side	4,62 €	5,50 €
Q091a	19152	Handle bar rubber for BMW R24-R90S, in-house production, round, pair	8,82 €	10,50 €
Q091b	720850	Handle bar rubber for BMW R24-R90S, Magura, round, pair	16,72 €	19,90 €
Q093	98154	Stud screw M 6 x 16 with pin	0,34 €	0,40 €
Q094	98130	Stud screw M 5 x 10 with pin end	0,15 €	0,18 €
Q094	98152	Stud screw M 6 x 8 with ball end	0,17 €	0,20 €
Q095	72109	Clutch lever for BMW R25-R25/3 and R51/3-R68	12,86 €	15,30 €
Q096	72132	Brake lever for BMW R25-R25/3 and R51/3-R68	12,86 €	15,30 €
Q097	30870	Clutch/brake lever bolt, early version, for BMW R25-R69S	2,23 €	2,65 €
Q099	1236462	Grommet brake hose, lower for BMW R45/R65, R80GS-R100R upper, R100RS/RT rear also be used for cable management R24-R69S	2,44 €	2,90 €
Q100	0072112	Clutch control housing for BMW R25, R25/2, R25/3 and R51/2-R68	29,41 €	35,00 €
Q101	72164	Throttle control unit complete for BMW R25, R25/2 and R25/3	87,94 €	104,65 €
Q102	72274	Cable connector handlebarholder for BMW R51/2-R68 black	10,59 €	12,60 €
Q103	72112	Clutch control unit for BMW R25-R25/3 and R51/3-R68, complete	48,74 €	58,00 €
Q104	72122	Cable adjustor screw M 6 for BMW R25-R68	2,52 €	3,00 €
Q105	36226	Split pin 2,0 x 32	0,13 €	0,15 €
Q105a	44136	Split pin for brake rod stainless steel	0,13 €	0,15 €
Q106	23420	Castle nut M 8x1 zined, fine thread	1,51 €	1,80 €
Q107	317025	Steering lock for BMW R25/3-R27, R50-R69S and R50/5-R100, short	9,92 €	11,80 €
Q108	16009	Lock combination steering / toolbox for BMW R25/3 and R50-R69S	42,52 €	50,60 €
Q109	5076	Lock for tool box for BMW R25/3 and R50-R69S	29,16 €	34,70 €
Q109	41036	Tool-wrench 36/41, vehicle tool kit for BMW R24-R69S	11,26 €	13,40 €
Q504	31044	Spoke for BMW R25/3 and R26 "old", M3,5 x 140 chromed, with nippel	1,85 €	2,20 €
Q505B	6044	Spoke for BMW R25/3-R27 and R50-R69S, R50/5 and up, rear, M4 x 140, (2x crossed) chromed, with nippel	1,01 €	1,20 €
Q505D	1047	Spoke for BMW R25/3-R27 and R50-R69S, R50/5 and up, rear, M4 x 140, (2x crossed) stainless steel, with nipple	1,22 €	1,45 €
Q999	04619	Stud screw M 6 X 25 with pin end	0,29 €	0,35 €



Group R: Fork and steering R51/2-R68

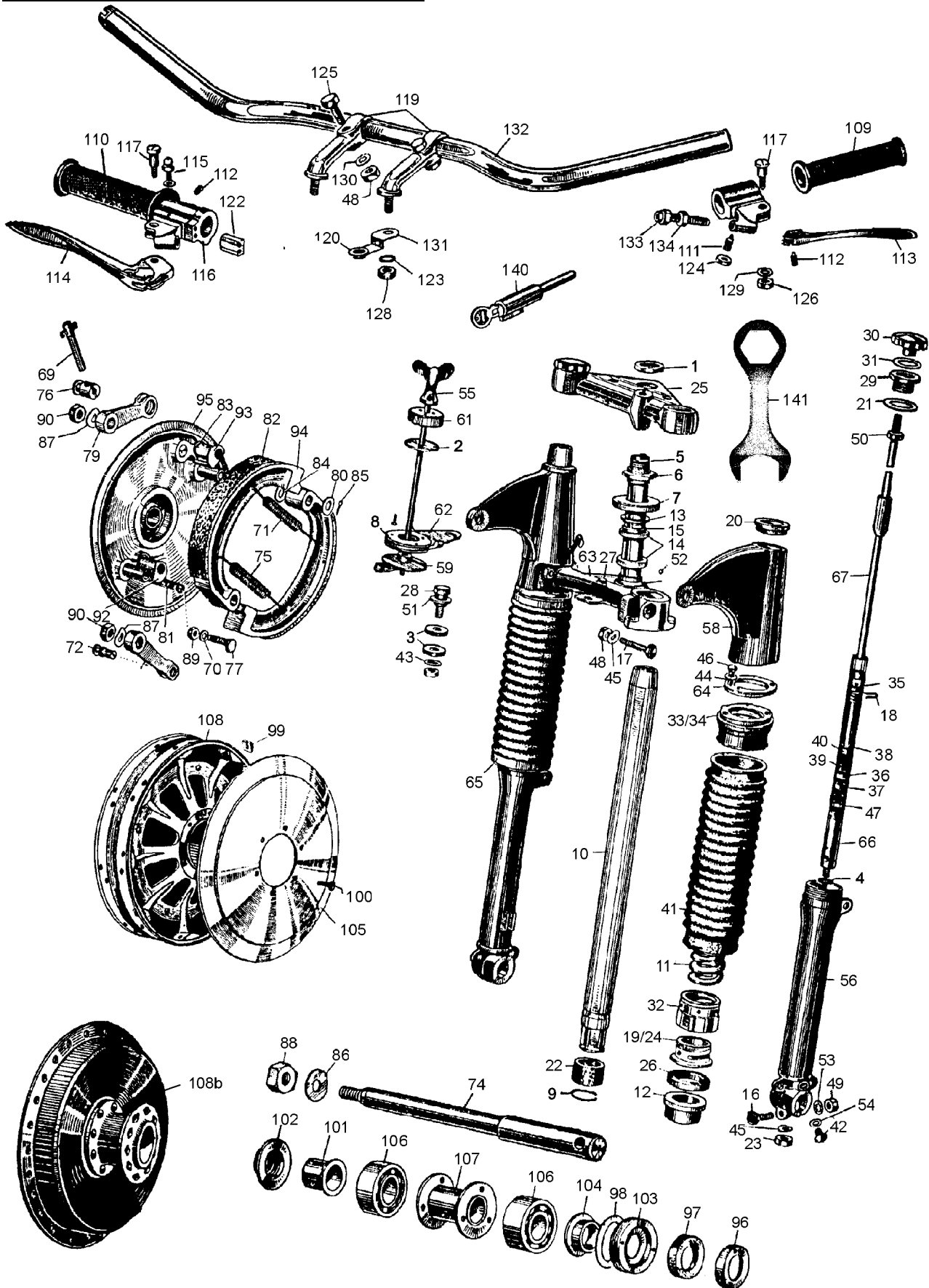

<u>Picture-No.</u>	<u>Article-No.</u>	<u>Description</u>	<u>Net</u>	<u>Gross</u>
R0	22093	Nut M 8 x 1 zincked	0,25 €	0,30 €
R00	8080165	Guide plate cable holder for BMW R25/2 and R51/3-R68 mount on lower fork yoke	15,93 €	18,96 €
R000	97002	Wrench wheel bearing retainert nut for BMW R51/2-R69S (also useable for prewar-R51)	24,12 €	28,70 €
R000	9071	Rim for BMW R51/2-R68, semi-hub, black/silver painted for 5mm spokes	155,00 €	184,45 €
R000	0060211	Bolt brake shoes storage for BMW R51/3, R67/2 and R67/3	6,56 €	7,81 €



R0000	2002151	Fork cover for BMW R51/2-R68, bottom, 2 grooves	22,27 €	26,50 €
R0000	2002150	Fork cover for BMW R51/2-R68, bottom, 3 grooves	22,27 €	26,50 €
R001	00101	Counter nut, fork bridge for BMW R25-R69S	6,22 €	7,40 €
R002	00245	Steering damper lock washer for BMW R25-R69S	8,78 €	10,45 €
R003	00257	Rubber ring for steering damper bolt for BMW R25-R69S	1,64 €	1,95 €
R004	54140	Gasket ring fork BMW R25/3, R51/2-R68 and R50/5-R75/5 for shock tube, low	0,42 €	0,50 €
R006	00182	Steering adjusting nut for BMW R24-R69S	8,32 €	9,90 €
R007	00184	Dust cap steering head for BMW R25-R69S	6,30 €	7,50 €
R008	7051	Steering damper friction plate for BMW R24-R69S	2,86 €	3,40 €
R009	00400	Lock ring fork bushing for BMW BMW R51/3-R68	0,72 €	0,85 €
R010	00405	Fork tube for BMW R51/2-R68 used	58,74 €	69,90 €
R010	00404	Fork tube for BMW R51/2-R68 chromed - also fits on R51, R66, R61, R71	193,19 €	229,90 €
R011	04252	Fork spring for BMW R51/2-R68, reinforced	18,49 €	22,00 €
R011a	0042521	Fork spring for BMW R51/2-R68, solo, 5,5mm	19,33 €	23,00 €
R012	00408	Bushing fork for BMW R51/2-R68, upper	13,28 €	15,80 €
R014	3025	Steering head bearing set for BMW R25-R69S, tapered	40,34 €	48,00 €
R014a	5590040	Ballbearing set steering head for BMW R24-R69S true to original	40,34 €	48,00 €
R016	54262	Axle bolt for BMW R25-R25/2 and R51/3-R68, front stainless steel, precision-turned	16,89 €	20,10 €
R017	00416	Fork pinch bolt for BMW R51/2-R68	10,88 €	12,95 €
R018	2054160	Clamp spring, damper tube, fork for BMW 25/3 and R51/3-R68	6,05 €	7,20 €
R019	3004334	Spacer sleeve rear drive for BMW R50-R69S	10,84 €	12,90 €
R020	54282	Fork rubber ring for BMW R51/2-R68	2,35 €	2,80 €
R021	054284	Washer fork yoke top for BMW R51/3-R68	7,31 €	8,70 €
R022	00406	Bushing fork for BMW R51/2-R68, lower bronze	19,24 €	22,90 €
R025	00438	Top fork yoke for BMW R51/3-R68 used	83,95 €	99,90 €
R026	00425	Radial seal ring, fork for BMW R51/2-R68	9,20 €	10,95 €
R027	36102	Rubber plug generator for BMW R24-R26 and fork guide for BMW R51/3	0,67 €	0,80 €
R028	00256	Steering damper bolt for BMW R26, R27 and R51/2-R69S	4,87 €	5,80 €
R029	54256	Fork mounting piece for BMW R51/2-R68	16,22 €	19,30 €
R030	89031	Aluminium cap for fork for BMW R51/3-R68	15,88 €	18,90 €
R031	22053	Gasket for aluminium cap top for fork for BMW R51/3-R68	1,05 €	1,25 €
R034	2054289	Fork spring bracket for BMW R51/2-R68, solo version for forkboot	57,98 €	69,00 €
R041	54292	Rubber boot fork for BMW R51/3-R68	15,13 €	18,00 €
R042	16652	Fork oil drain screw M 6x6 allen-head, semicircle for BMW R51/2-R68 stainless steel	1,60 €	1,90 €
R042	16651	Fork oil drain screw M 6 allen-head for BMW R51/3-R68 stainless steel	0,76 €	0,90 €
R042a	9916651	Fork oil drain screw for BMW R51/2-R68, halfround head stainless steel, orig.style	5,38 €	6,40 €
R044	98454	Spring washer B 6, DIN137 zincked	0,05 €	0,06 €
R045	54140	Gasket ring fork BMW R25/3, R51/2-R68 and R50/5-R75/5 for shock tube, low	0,42 €	0,50 €
R046	98157	Screw M 6 x 20, hexagon	0,13 €	0,15 €
R048	98352	Nut M 8 zinked	0,17 €	0,20 €
R048	0098352	Nut M 8, wrench size 14 zincked	1,01 €	1,20 €
R049	99001	Nut M 8 x 1, fine pitch thread stainless steel	0,97 €	1,15 €
R051	31851	Washer steering damper bolt for BMW R25-R69S	0,42 €	0,50 €
R054	63037	Gasket ring fork for BMW R51/2-R68 und R80 from year of manufacture 1985, M6 and R45, R65	0,25 €	0,30 €
R055	00045	Steering damper knob for BMW R25-R25/3 and R51/3-R68	32,69 €	38,90 €
R056	54210	Fork sliding tube for BMW R51/3-R68 used - Please indicate which side (left or right) is needed!	134,45 €	160,00 €
R057	2002161	Fork jacket for BMW R51/2-R68, top left side, until year of manufacture 09/1952 grounded	48,32 €	57,50 €
R057a	02160	Fork jacket for BMW R51/2-R68, top right side, until year of manufacture 09/1952 grounded	48,32 €	57,50 €
R058	02170	Headlight ear for BMW R51/2-R68, right side varnished black	41,51 €	49,40 €
R058a	2002170	Headlight ear for BMW R51/2-R68, left side varnished black	41,51 €	49,40 €
R059	00450	Pressure plate steering damper for BMW R51/2-R68	22,27 €	26,50 €
R061	00114	Steering damper cap for BMW R25-R27 and R51/3-R69S chromed	14,20 €	16,90 €
R062	00447	Steering damper resistance plate for BMW R51/3-R68	23,19 €	27,60 €
R063	00440	Lower fork yoke for BMW R51/3-R68 used	159,66 €	190,00 €
R064	2054296	Gasket for spring seat fork for BMW R51/3-R68	7,48 €	8,90 €
R064A	2054297	Baseplate for spring seat fork R51/3-R68	7,48 €	8,90 €
R065	9952090	Clamp gearbox boot for BMW R50-R69S, front solid measure: Ø=90,0mm, original shape	4,12 €	4,90 €
R065	9191191	Clamp fork boot for BMW R51/3-R68 (clamp with screw)	1,30 €	1,55 €
R065a	2054294	Clamp fork boot for BMW R51/3-R68 solid measure: Ø=64mm, original-shape, stainless steel	4,20 €	5,00 €
R067	51268	Fork damper unit for BMW R51/2-R68	151,18 €	179,90 €
R069	10055	Brake cable adjusting screw brass	8,91 €	10,60 €
R071	60239	Brake-shoe spring for BMW R51/3-R69S, front upper	2,48 €	2,95 €



R072A	60264	Brake cable bolt for BMW R51/2-R68 SIMPLEX and DUPLEX front lower stainless steel	10,67 €	12,70 €
R074	60222	Wheel axle for BMW R51/2, front, left-hand thread stainless steel	60,00 €	71,40 €
R074A	60223	Wheel axle for BMW R51/3-R68, front chromed	51,51 €	61,30 €
R075	60237	Brake-shoe spring for BMW R51/3-R69S, front and rear lower	2,73 €	3,25 €
R076	60143	Brake cable bolt WITH thread for BMW R25/3-R27 and R51/3-R68 DUPLEX, upper	3,19 €	3,80 €
R077	60167	Eccentric bolt Duplex for BMW R51/3-R69S stainless steel	16,22 €	19,30 €
R077a	60277	Eccentric bolt spring Duplex for BMW R51/3-R69S	4,12 €	4,90 €
R079a	60212	Brake lever for BMW R51/2-R68, front upper, duplex used	30,00 €	35,70 €
R079B	60209	Brake lever for BMW R51/2-R68, front, simplex used	19,24 €	22,90 €
R080	2060269	Washer brake shoe for BMW R51/3-R68 and R50-R69S	1,43 €	1,70 €
R082A	5051	Brake lining for BMW R51/2-R68, semi-hub	10,00 €	11,90 €
R082B	3051	Brake lining for BMW R51/3-R68, full-hub	10,00 €	11,90 €
R082c	0008051	Rivet bolts brake lining for BMW R51/2-R69S, 50 pcs., 10mm long	3,36 €	4,00 €
R083	60211	Brake lever for BMW R51/3-R68, front lower, duplex used	30,00 €	35,70 €
R085	36226	Split pin 2,0 x 32	0,13 €	0,15 €
R089	22093	Nut M 8 x 1 zincked	0,25 €	0,30 €
R090	21615	Nut M10 x 1, flat for brake-key and shockabsorber, rear	0,50 €	0,60 €
R092A	60312	Brake spanner for BMW R51/3, R67 and R68, front lower, half hub duplex used	21,01 €	25,00 €
R092B	60310	Brake spanner for BMW R51/3, R67 and R68, front lower, full-hub used	21,01 €	25,00 €
R092C	60205	Brake spanner for BMW R51/3, R67 and R68, front, simplex used	25,50 €	30,35 €
R093	60311	Brake spanner for BMW R51/3, R67 and R68 full hub, front, upper used	21,01 €	25,00 €
R093B	60313	Brake spanner for BMW R51/3, R67 and R68, front upper, half hub duplex used	21,01 €	25,00 €
R094	1160201	Brake-shoe Set for BMW R51/3, R67/2, R67/3 and R68, front wheel, semi-hub, Duplex, NEW (Set = 2 pc. for 1 front wheel)	40,67 €	48,40 €
R094B	60200	Brake-shoe Set for BMW R51/2-R68, semi-hub, simplex (Set = 2 pc. for 1 front or rear wheel)	40,67 €	48,40 €
R095A	75031	Brakeanchor plate for BMW R51/3*R68, WITHOUT attachment parts, full-hub used	150,00 €	178,50 €
R095B	76031	Brake anchor plate for BMW R51/2 and R51/3-R68, semi-hub, Simplex complete with break-key and lever, Repro, "without break shoes"	123,02 €	146,39 €
R096	38255	Felt ring cap wheel bearing for BMW R51/2-R69S	3,19 €	3,80 €
R097	38259	Felt ring for wheel bearing for BMW R50-R69S	2,10 €	2,50 €
R098	9231651	Distance washer Wheel-baering for BMW R51/3-R68, 0,20mm	2,69 €	3,20 €
R098	9231652	Distance washer Wheel-bearing for BMW R51/3-R68, 0,30mm	2,69 €	3,20 €
R098	9231653	Distance washer Wheel-bearing for BMW R51/3-R68, 0,38mm	2,69 €	3,20 €
R098	9231654	Distance washer Wheel-bearing for BMW R51/3-R68, 0,50mm	2,69 €	3,20 €
R098	9231655	Distance washer Wheel-bearing for BMW R51/3-R68, 0,60mm	2,69 €	3,20 €
R098	9231656	Distance washer Wheel-bearing for BMW R51/3-R68, 0,75mm	2,69 €	3,20 €
R098	9231657	Distance washer Wheel-bearing for BMW R51/3-R68, 0,88mm	2,69 €	3,20 €
R098	9231658	Distance washer Wheel-bearing for BMW R51/3-R68, 1,00mm	2,69 €	3,20 €
R099	15001	Spoke adaptor square	1,22 €	1,45 €
R100	38181	Screw for hub-cap for BMW R25/3-R68, M 6 chromed, wrench size 9mm	2,10 €	2,50 €
R101	38239	Thrust sleeve for BMW R51/3-R68, right side	10,17 €	12,10 €
R102	38240	Thrust sleeve for BMW R51/3-R68, right side, big	7,14 €	8,50 €
R103	38270	Wheel bearing retainer for BMW R51/2-R68, WITH felt-ring and felt	9,20 €	10,95 €
R103A	4038270	Wheel bearing retainer for BMW R51/2-R68 WITHOUT felt-ring and felt stainless steel	22,86 €	27,20 €
R104	38237	Thrust sleeve for BMW R51/3-R68, left side	6,18 €	7,35 €
R105	938274	Hubcap for BMW R51/3, R67/3 and R68, full-hub aluminium, polished	33,53 €	39,90 €
R106	40641	Wheel bearing for BMW R51/3-R68, double seal	8,15 €	9,70 €
R107	38223	Spacer sleeve wheel bearing for BMW R51/2-R68, outer	12,77 €	15,20 €
R108A	0000313	Wheel hub inner part for BMW R51/2-R68, semi-hub with wheel attachment	250,84 €	298,50 €
R108AA	0001077	Wheel hub inner part for BMW R51/3, R67/3 and R68, full-hub with wheel attachment	310,21 €	369,15 €
R110	72167	Throttle twist tube for BMW R25-R25/3 and R51/3-R68	18,07 €	21,50 €
R111	98154	Stud screw M 6 x 16 with pin	0,34 €	0,40 €
R112	98130	Stud screw M 5 x 10 with pin end	0,15 €	0,18 €
R112	98152	Stud screw M 6 x 8 with ball end	0,17 €	0,20 €
R113	72109	Clutch lever for BMW R25-R25/3 and R51/3-R68	12,86 €	15,30 €
R114	72132	Brake lever for BMW R25-R25/3 and R51/3-R68	12,86 €	15,30 €
R116A	72388	Throttle control unit complete for BMW R51/2-R67/3	87,90 €	104,60 €
R116B	7216602	Throttle control housing for BMW R51/3, R67 and R68	67,14 €	79,90 €
R116C	72389	Throttle control cover for BMW R51/2-R68	12,77 €	15,20 €
R117	30870	Clutch/brake lever bolt, early version, for BMW R25-R69S	2,23 €	2,65 €
R117A	22174	Clutch/brake lever bolt for BMW R25-R69S stainless steel, polished	8,32 €	9,90 €
R119	72301	Handlebar riser for BMW R51/2-R67/3, (fits also for R68) stainless steel chromed	49,12 €	58,45 €
R119a	7230168	Handlebar riser for BMW R68 stainless steel chromed	77,90 €	92,70 €
R121	72112	Clutch control unit for BMW R25-R25/3 and R51/3-R68, complete	48,74 €	58,00 €



R121A	0072112	Clutch control housing for BMW R25, R25/2, R25/3 and R51/2-R68	29,41 €	35,00 €
R122	72392	Throttle control sliding block for BMW R51/2-R68	12,77 €	15,20 €
R125	22081	Screw for handlebar riser for BMW R51/2-R68 stainless steel	2,52 €	3,00 €
R125	1402028	Screw for handlebar riser for BMW R51/2-R68 and R69, short handlebar stainless steel polished	5,80 €	6,90 €
R128	22122	Nut M10 x 1 zincked	0,34 €	0,40 €
R132A	0072513	Handlebar for BMW R25 and R51/2-R67/3, original shape	29,33 €	34,90 €
R132C	94052	Handlebar for side car use, universal, flat 750mm wide, Fehling	41,51 €	49,40 €
R132D	72002	Handlebar (touring) medium high 95mm high, 670mm wide	27,73 €	33,00 €
R132E	5052	Handlebar half-high, similar to BMW R50/5, R60/5 and R75/5 145mm high, 765mm wide, Fehling, US-Version	48,82 €	58,10 €
R132EA	72036	Handlebar for BMW R50-R69S, half-high with cross bar 160mm high, 750mm wide, US-Version	42,69 €	50,80 €
R133	72122	Cable adjustor screw M 6 for BMW R25-R68	2,52 €	3,00 €
R140	1025	Steering lock for BMW R25, R25/2 and R51/2-R68, long	16,30 €	19,40 €
R141	41036	Tool-wrench 36/41, vehicle tool kit for BMW R24-R69S	11,26 €	13,40 €
R502A	38208	Spoke for BMW R51/3-R68, M3,5 x 125, full hub, thick end chromed, with nipple	1,93 €	2,30 €
R502B	8044	Spoke for BMW R51/3-R68, M4 x 125, full hub chromed, with nipple	1,01 €	1,20 €
R502C	8045	Spoke for BMW R51/3-R68, M4 x 125, full hub stainless steel, with nipple	1,22 €	1,45 €
R502D	25044	Spoke for BMW R51/2-R68, M5 x 127, half hub, short chromed, with nipple	1,01 €	1,20 €
R502E	7044	Spoke for BMW R51/2-R68, M4 x 210, half hub, long chromed, with nipple, also for side car	1,01 €	1,20 €
R502F	5044	Spoke for BMW R51/2-R68, M5 x 127, half hub, short, thick end chromed, WITHOUT nipple	1,93 €	2,30 €
R502G	4044	Spoke for BMW R51/2-R68, M5 x 212, half hub, long, thick end chromed, WITHOUT nipple	1,93 €	2,30 €
R999	4038323	Rim for BMW R51/2-R68, semi-hub, stainless steel polished for 5mm spokes	171,43 €	204,00 €
R999	4038326	Rim for BMW R51/3-R68, full-hub, stainless steel polished for 4mm spokes	171,43 €	204,00 €
R999	04619	Stud screw M 6 X 25 with pin end	0,29 €	0,35 €
R999	38324	Rim for BMW R51/3-R68, full-hub, chrome for 4mm spokes	100,76 €	119,90 €
R999	38325	Rim for BMW R51/3-R68, full-hub, high shoulder, aluminum for 4mm spokes	201,60 €	239,90 €
R999	3071	Rim for BMW R51/2-R68 semi-hub, chrome for 5mm spokes	100,76 €	119,90 €
R999	5071	Rim for BMW R51/2-R68, semi hub, crude for 5mm spokes	92,35 €	109,90 €
R999	8070110	Grommet guide plate for BMW R25/2, R25/3 and R51/3-R68	2,94 €	3,50 €



Group S: Front swing and steering all models 1955-1969, rims, spokes, tires

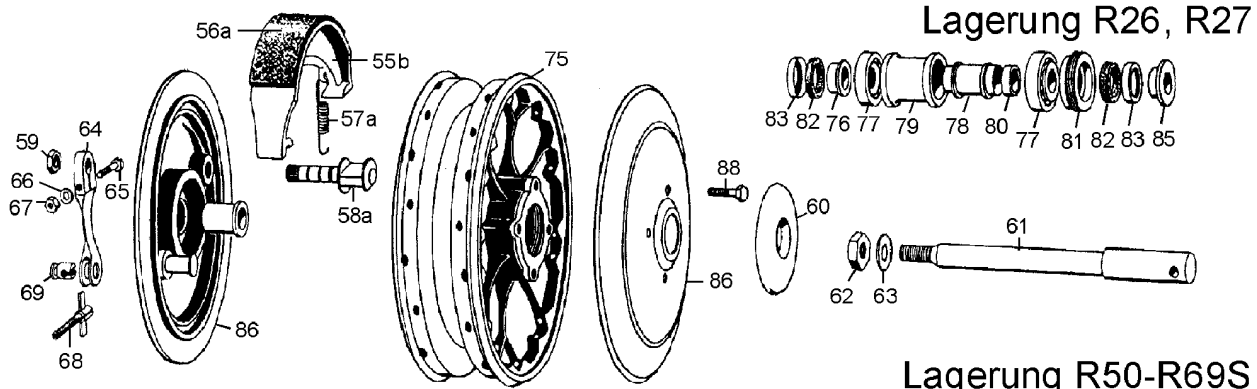

Lagerung R26, R27

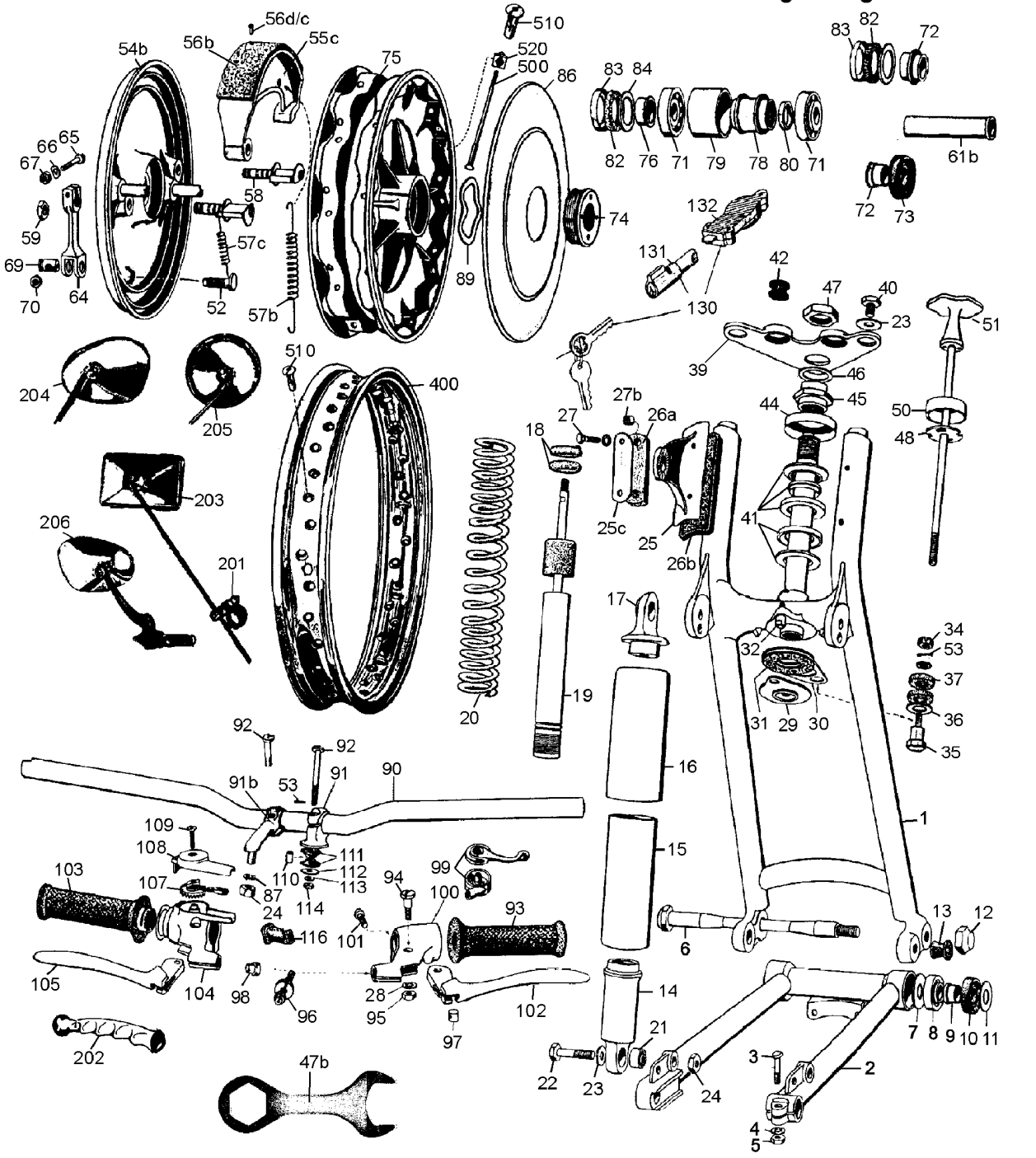

Lagerung R50-R69S

Picture-No.	Article-No.	Description	Net	Gross
S000	135017	Tire 3.25-17, Avon, AM7 MKII replacement for 3.50-17, REMNANTS	83,19 €	99,00 €
S000	132518	Tire 3.25S18, Metzeler, Block C for BMW R25/3, R26 and R27	90,67 €	107,90 €
S000	435019	Tire 3.50S19, Metzeler, ME77, for front wheel for BMW R51/2-R68	80,00 €	95,20 €
S000	72284	Grease port, M6x1, standard thread	1,60 €	1,90 €



S000	97002	Wrench wheel bearing retainert nut for BMW R51/2-R69S (also useable for prewar-R51)	24,12 €	28,70 €
S000	97003	Wrench wheel bearing retainert nut for BMW R25-R27	24,12 €	28,70 €
S000	432519	Tire 3.25-19, Metzeler, Block C for BMW R25 and R25/2	100,76 €	119,90 €
S000	9960270	Grease port, M8x1, convex, earles fork for BMW R50-R69S	1,60 €	1,90 €
S000	9991001	Hubcap for BMW R26 and R27 silver painted, 2nd Quality	8,40 €	10,00 €
S000	9988001	Hubcap for BMW R50-R69S silver painted, 2nd Quality	10,08 €	12,00 €
S000	9988002	Hubcap for BMW R50-R69S chromed, 2nd Quality	15,13 €	18,00 €
S001A	73031	Earls fork for BMW R26 and R27, upper used	251,26 €	299,00 €
S001B	80031	Earls fork for BMW R50-R69S, upper used, checked	403,36 €	480,00 €
S002A	82031	Swingarm for BMW R26 and R27, front used	75,63 €	90,00 €
S002B	81031	Swingarm for BMW R50-R69S, front used	191,60 €	228,00 €
S003	14062	Axle bolt for BMW R26-R69S, front stainless steel	12,77 €	15,20 €
S005B	99001	Nut M 8 x 1, fine pitch thread stainless steel	0,97 €	1,15 €
S006	00321	Swingarm axle for BMW R26, R27 and R50-R69S stainless steel	41,93 €	49,90 €
S006A	00320	Swingarm axle for BMW R26, R27 and R50-R69S zincd	28,91 €	34,40 €
S007	20136	Washer earles swing front/inner and gearbox inlet for BMW R50-R69S	2,44 €	2,90 €
S008	13064	Wheel bearing for BMW R26, R27, R50/5-R100 and R45/R65 until year of manufacture 09/1984 and rocker arm for BMW R26, R27, R50-R69S and R50/5-R100, front and rear	15,88 €	18,90 €
S008	0013064	Wheel bearing for BMW R26, R27 and R50/5-R100, +0,10 overmeasure and rocker arm for BMW R26, R27 and R50-R69S, front and rear	35,88 €	42,70 €
S008	0013065	Wheel bearing for BMW R26, R27 and R50/5-R100, +0,15 overmeasure and rocker arm for BMW R26, R27 and R50-R69S, front and rear	39,41 €	46,90 €
S009	00324	Thrust sleeve swingarm for BMW R26-R100	5,84 €	6,95 €
S010	00331	Radial seal ring, swingarm for BMW R26, R27, R50-R69S and R50/5-R100 until 09/1980	3,19 €	3,80 €
S011A	31198	Distance washer "Earles fork" for BMW R26, R27 and R50-R69S, front, 2,0mm	2,65 €	3,15 €
S011A	31196	Distance washer "Earles fork" for BMW R26, R27 and R50-R69S, front, 1,0mm	2,65 €	3,15 €
S011A	31197	Distance washer "Earles fork" for BMW R26, R27 and R50-R69S, front, 1,5mm	2,65 €	3,15 €
S011B	31199	Distance washer "Earles fork" for BMW R26, R27 and R50-R69S, front, 2,5mm	2,65 €	3,15 €
S011C	31200	Distance washer "Earles fork" for BMW R26, R27 and R50-R69S, front, 3,0mm	3,28 €	3,90 €
S012	00328	Cap nut for swing arm axle for BMW R26, R27 and R50-R69S stainless steel	12,27 €	14,60 €
S013	00332	Rubber plug for earles fork for BMW R26, R27 and R50-R69S	3,19 €	3,80 €
S014	28030	Shock absorber mounting for BMW R26, R27 and R50-R69S, front lower	40,25 €	47,90 €
S015	2077	Shock cover for BMW R26-R69S, front lower aluminium	19,16 €	22,80 €
S016	3077	Shock cover for BMW R26-R69S, front upper black painted, aluminium	22,02 €	26,20 €
S017	130031	Shock absorber mounting for BMW R26, R27 and R50-R69S, front upper used	15,13 €	18,00 €
S017	1300311	Shock absorber mounting for BMW R26, R27 and R50-R69S, front upper	41,93 €	49,90 €
S018	54528	Stop rubber for shock absorber for BMW R26, R27 and R50-R69S, front and rear	1,93 €	2,30 €
S019	2054031	Shock absorber for BMW R26 and R27, front	80,00 €	95,20 €
S019A	2054032	Shock absorber for BMW R50-R69S, front	80,00 €	95,20 €
S020	540071	Spring for BMW R26, R27 and R50-R69S, front suspension for sidecar use	14,12 €	16,80 €
S020	54007	Spring for BMW R26, R27 and R50-R69S, front suspension for solo use	14,12 €	16,80 €
S021	46016	Silent block for BMW R26, R27 and R50-R69S, small	3,49 €	4,15 €
S022A	13346	Suspension unit locking screw for BMW R26, R27 and R50-R69S, front, upper and for BMW R26 and R27, lower and rear left side, chromed	5,00 €	5,95 €
S022B	14345	Suspension unit locking screw for BMW R26, R27 and R50-R69S, front, upper and for BMW R26 and R27, lower, stainless steel	6,64 €	7,90 €
S022C	14347	Suspension unit locking screw for BMW R50-R69S, front, lower, R26-R27 for mudguard with middle brace stainless steel	6,64 €	7,90 €
S023B	00345	Washer shock and fork bolt for BMW R26, R27 and R50-R69S stainless steel, polished	3,32 €	3,95 €
S023Ba	2000345	Washer shock and fork bolt for BMW R26, R27 and R50-R69S chrome-plated	2,10 €	2,50 €
S024A	22122	Nut M10 x 1 zincd	0,34 €	0,40 €
S024B	98365	Nut M10 x 1, fine pitch thread stainless steel	1,26 €	1,50 €
S025A	00306	Headlight ear for BMW R26, R27 and R50-R69S, left side varnished black	28,11 €	33,45 €
S025B	00314	Headlight ear for BMW R26-R69S, right side varnished black	28,11 €	33,45 €
S025C	00347	Headlight ear mounting sheet for BMW R26, R27 and R50-R69S	2,35 €	2,80 €
S026A	00338	Headlight mount rubber for BMW R26, R27 and R50-R69S, small	5,29 €	6,30 €
S026B	00336	Headlight mount rubber for BMW R26, R27 and R50-R69S, large	6,89 €	8,20 €
S027	98160	Screw M 6 x 20, hexagon stainless steel	0,25 €	0,30 €
S027	98157	Screw M 6 x 20, hexagon	0,13 €	0,15 €
S027B	00340	Distance sleeve for headlight bracket for BMW R26-R69S	2,94 €	3,50 €
S029	00231	Pressure plate steering damper for BMW R26, R27 and R50-R69S	18,91 €	22,50 €
S030	00220	Steering damper resistance plate for BMW R26 and R27	14,83 €	17,65 €
S030	00217	Steering damper resistance plate for BMW R50-R69S	15,88 €	18,90 €
S031	7051	Steering damper friction plate for BMW R24-R69S	2,86 €	3,40 €
S032	00295	Steering damper bolt Earles fork for BMW R26, R27 and R50-R69S stainless steel	7,23 €	8,60 €
S034	23421	Castle nut M 8 zincd	0,97 €	1,15 €



S035	00256	Steering damper bolt for BMW R26, R27 and R51/2-R69S	4,87 €	5,80 €
S036	31851	Washer steering damper bolt for BMW R25-R69S	0,42 €	0,50 €
S037	00257	Rubber ring for steering damper bolt for BMW R25-R69S	1,64 €	1,95 €
S039A	00124	Top fork yoke for BMW R26 new painted	33,53 €	39,90 €
S039B	00129	Top fork yoke for BMW R27	33,53 €	39,90 €
S039C	00349	Top fork yoke for BMW R50-R69S used	21,01 €	25,00 €
S039D	00350	Top fork yoke for BMW R50-R69S fits with /5 handlebar mounts	41,93 €	49,90 €
S039E	00351	Top fork yoke for BMW R50-R69S	33,53 €	39,90 €
S040A	00343	Top fork bolt for BMW R26, R27 and R50-R69S chrome plated	3,95 €	4,70 €
S040B	00344	Top fork bolt for BMW R26, R27 and R50-R69S stainless steel polished	5,63 €	6,70 €
S041	3025	Steering head bearing set for BMW R25-R69S, tapered	40,34 €	48,00 €
S041a	5590040	Ballbearing set steering head for BMW R24-R69S true to original	40,34 €	48,00 €
S042	00299	Rubber plug for upper fork yoke for BMW R50-R69S	0,97 €	1,15 €
S044	00184	Dust cap steering head for BMW R25-R69S	6,30 €	7,50 €
S045	00182	Steering adjusting nut for BMW R24-R69S	8,32 €	9,90 €
S046	1231200	Spacer washer steering for BMW R26, R27 and R50-R69S - 1,0mm	3,11 €	3,70 €
S046A	31201	Spacer washer steering for BMW R26, R27 and R50-R69S - 1,5mm	2,69 €	3,20 €
S046B	31202	Spacer washer steering for BMW R26, R27 and R50-R69S - 2,0mm	2,69 €	3,20 €
S046C	31203	Spacer washer steering for BMW R26, R27 and R50-R69S - 2,5mm	2,69 €	3,20 €
S046D	31204	Spacer washer steering for BMW R26, R27 and R50-R69S - 3,0mm	2,69 €	3,20 €
S047	00101	Counter nut, fork bridge for BMW R25-R69S	6,22 €	7,40 €
S047B	41036	Tool-wrench 36/41, vehicle tool kit for BMW R24-R69S	11,26 €	13,40 €
S048	00245	Steering damper lock washer for BMW R25-R69S	8,78 €	10,45 €
S049	90425	Spacer ring fork steering for BMW /5 fork in old frame	8,32 €	9,90 €
S050	00114	Steering damper cap for BMW R25-R27 and R51/3-R69S chromed	14,20 €	16,90 €
S051	00049	Steering damper knob for BMW R26, R27 and R50-R69S	81,01 €	96,40 €
S051a	2054071	Steering damper hydraulic for BMW R50S and R69S without mounting parts!	107,56 €	128,00 €
S051b	2054072	Hydraulic steering damper complete for BMW R50S and R69S with mounting parts	714,28 €	849,99 €
S052	60167	Eccentric bolt Duplex for BMW R51/3-R69S stainless steel	16,22 €	19,30 €
S052b	2060269	Washer brake shoe for BMW R51/3-R68 and R50-R69S	1,43 €	1,70 €
S052c	36226	Split pin 2,0 x 32	0,13 €	0,15 €
S053	36226	Split pin 2,0 x 32	0,13 €	0,15 €
S053a	44136	Split pin for brake rod stainless steel	0,13 €	0,15 €
S054A	78031	Brake anchor plate for BMW R26 and R27, WITHOUT attachment parts used	84,03 €	100,00 €
S054B	74031	Brake anchor plate for BMW R50-R69S, WITHOUT attachment parts used	117,56 €	139,90 €
S055	1160203	Brake-shoe Set for BMW R50-R69S, front wheel, NEW (Set = 2pc. for 1 front wheel)	40,67 €	48,40 €
S055	6010301	Brake-shoe Set for BMW R25/3, R26 and R27, NEW (Set = 2pc. for 1 front or rear wheel)	40,67 €	48,40 €
S056A	2051	Brake lining for BMW R25/3, R26 and R27	10,00 €	11,90 €
S056B	1051	Brake lining for BMW R50-R69S	10,00 €	11,90 €
S056C	0098051	Rivet bolts brake lining for BMW R24-R27, 50 pcs., 8mm long	3,36 €	4,00 €
S056D	0008051	Rivet bolts brake lining for BMW R51/2-R69S, 50 pcs., 10mm long	3,36 €	4,00 €
S057A	60134	Brake-shoe spring for BMW R25-R27	2,48 €	2,95 €
S057B	60237	Brake-shoe spring for BMW R51/3-R69S, front and rear lower	2,73 €	3,25 €
S057C	60277	Eccentric bolt spring Duplex for BMW R51/3-R69S	4,12 €	4,90 €
S057C	60239	Brake-shoe spring for BMW R51/3-R69S, front upper	2,48 €	2,95 €
S058A	60104	Brake spanner for BMW R25/3, R26 and R27, front used	12,86 €	15,30 €
S058B	60207	Brake spanner for BMW R50-R69S, front upper original BMW - REMNANTS!	25,13 €	29,90 €
S058C	60206	Brake spanner for BMW R50-R69S, front lower original BMW - REMNANTS!	25,13 €	29,90 €
S058D	60258	Washer brake key used	0,42 €	0,50 €
S059A	21615	Nut M10 x 1, flat for brake-key and shockabsorber, rear	0,50 €	0,60 €
S059B	22094	Nut M 8 x 1, flat for brake key	0,29 €	0,35 €
S060	9077	Hubcap for BMW R26 and R27, small silver painted	9,41 €	11,20 €
S060A	60171	Hubcap for BMW R26 and R27, small chromed	12,52 €	14,90 €
S061A	60227	Wheel axle for BMW R26, R27 and R50-R69S, front stainless steel polished	50,34 €	59,90 €
S061B	60174	Reducing bush wheel axle for BMW R50-R69S	19,54 €	23,25 €
S061B	0060227	Wheel axle for BMW R26, R27 and R50-R69S, front zincked	17,23 €	20,50 €
S061B	2060337	Reducing bush wheel axle for BMW R50-R69S, US-Version! and for telefork BMW R50/5, R60/5 and R75/5	24,12 €	28,70 €
S062a	22155	Nut M14 x 1,5 for wheel axle for BMW R24-R69S zincked	0,76 €	0,90 €
S063	04378	Washer for wheel axle for BMW R24-R69S zincked	0,38 €	0,45 €
S063	31089	Washer for wheel axle for BMW R24-R69S stainless steel polished	4,86 €	5,78 €
S064A	60111	Brake lever for BMW R25/3, R26 and R27, front used	19,24 €	22,90 €
S064B	60210	Brake lever for BMW R50-R69S, front used	27,65 €	32,90 €
S065	98159	Screw M 6 x 30, hexagon with shaft	0,15 €	0,18 €
S066	98454	Spring washer B 6, DIN137 zincked	0,05 €	0,06 €



S068	10055	Brake cable adjusting screw brass	8,91 €	10,60 €
S069A	60143	Brake cable bolt WITH thread for BMW R25/3-R27 and R51/3-R68 DUPLEX, upper	3,19 €	3,80 €
S069B	30040	Brake cable bolt WITHOUT thread for BMW R50-R69S and R50/5-R60/6 drum brake, front	7,48 €	8,90 €
S070	60178	Nut brake cable adjuster for BMW R50-R69S and R50/5-R60/6 drum brake, front	2,69 €	3,20 €
S071	5064	Wheel bearing for BMW R50-R69S	15,88 €	18,90 €
S072A	38230	Thrust sleeve for BMW R50-R69S, left side for wheel bearing with felt ring	9,66 €	11,50 €
S072B	38243	Thrust sleeve for BMW R50-R69S, left side for wheel bearing with shaft sealing ring, stainless steel	10,08 €	12,00 €
S073	56562	Radial seal ring, wheel and camshaft for BMW R51/3-R69S	3,91 €	4,65 €
S074	38271	Wheel bearing retainer for BMW R50-R69S, for felt-ring stainless steel	47,23 €	56,20 €
S074	38272	Wheel bearing retainer for BMW R50-R69S, for sealing ring stainless steel	26,89 €	32,00 €
S074B	9038272	Wheel bearing retainer for BMW R50-R69S, for sealing ring zincked	26,85 €	31,95 €
S075A	38030	Wheel hub for BMW R25/3, R26 and R27 used, WITHOUT bearings/bushings/spacers/bearing seat	41,93 €	49,90 €
S075AB	030011	Wheel hub for BMW R26 and R27 with new bearings and power blasted	178,95 €	212,95 €
S075C	00090	Wheel bearing carrier repair work wheel hub must be delivered to us	92,02 €	109,50 €
S075D	88090	Wheel bearing carrier for BMW R25/3, R26 and R27	45,50 €	54,15 €
S075E	38198	Drive coupling rear wheel (hub) for BMW R50-R69S	67,10 €	79,85 €
S075F	30015	Drive coupling rear wheel repair for BMW R50-R69S - rebuilding Drive will be charged extra	54,62 €	65,00 €
S075G	2030017	Wheel hub for BMW R50-R69S used	378,15 €	450,00 €
S076A	038142	Thrust sleeve for BMW R25, R25/2 and R25/3 right/left side and for BMW R26, R27, right side	5,84 €	6,95 €
S076B	38241	Thrust sleeve for BMW R50-R69S, right side	10,00 €	11,90 €
S077	13064	Wheel bearing for BMW R26, R27, R50/5-R100 and R45/R65 until year of manufacture 09/1984 and rocker arm for BMW R26, R27, R50-R69S and R50/5-R100, front and rear	15,88 €	18,90 €
S077	0013064	Wheel bearing for BMW R26, R27 and R50/5-R100, +0,10 overmeasure and rocker arm for BMW R26, R27 and R50-R69S, front and rear	35,88 €	42,70 €
S077	0013065	Wheel bearing for BMW R26, R27 and R50/5-R100, +0,15 overmeasure and rocker arm for BMW R26, R27 and R50-R69S, front and rear	39,41 €	46,90 €
S078A	38127	Spacer pipe wheel bearing for BMW R25/3, R26 and R27, inner for taper bearing	9,20 €	10,95 €
S078B	38225	Spacer pipe wheel bearing for BMW R50-R69S, inner	13,70 €	16,30 €
S079A	38131	Spacer sleeve wheel bearing for BMW R25/3, R26 and R27, outer external, for conic bearing	9,20 €	10,95 €
S079B	38229	Spacer sleeve wheel bearing for BMW R50-R69S, outer	12,86 €	15,30 €
S080A	31241	Spacer ring wheel bearing for BMW R25/3-R27 and R50/5-R100RT, 6,75mm	2,94 €	3,50 €
S080A	31240	Spacer ring wheel bearing for BMW R25/3-R27 and R50/5-R100RT, 6,65mm	2,94 €	3,50 €
S080A	30782	Spacer ring wheel bearing for BMW R25/3-R27 and R50/5-R100RT, 6,35mm	2,94 €	3,50 €
S080A	30783	Spacer ring wheel bearing for BMW R25/3-R27 and R50/5-R100RT, 6,40mm	2,94 €	3,50 €
S080A	30784	Spacer ring wheel bearing for BMW R25/3-R27 and R50/5-R100RT, 6,45mm	2,94 €	3,50 €
S080A	30785	Spacer ring wheel bearing for BMW R25/3-R27 and R50/5-R100RT, 6,50mm	2,94 €	3,50 €
S080A	30786	Spacer ring wheel bearing for BMW R25/3-R27 and R50/5-R100RT, 6,55mm	2,94 €	3,50 €
S080A	30787	Spacer ring wheel bearing for BMW R25/3-R27 and R50/5-R100RT, 6,60mm	2,94 €	3,50 €
S080A	30789	Spacer ring wheel bearing for BMW R25/3-R27 and R50/5-R100RT, 6,80mm	2,94 €	3,50 €
S080A	31242	Spacer ring wheel bearing for BMW R25/3-R27 and R50/5-R100RT, 6,85mm	2,94 €	3,50 €
S080A	31243	Spacer ring wheel bearing for BMW R25/3-R27 and R50/5-R100RT, 6,90mm	2,94 €	3,50 €
S080A	31244	Spacer ring wheel bearing for BMW R25/3-R27 and R50/5-R100RT, 6,95mm	2,94 €	3,50 €
S080A	31245	Spacer ring wheel bearing for BMW R25/3-R27 and R50/5-R100RT, 7,00mm	2,94 €	3,50 €
S080A	31246	Spacer ring wheel bearing for BMW R25/3-R27 and R50/5-R100RT, 7,05mm	2,94 €	3,50 €
S080A	31248	Spacer ring wheel bearing for BMW R25/3-R27 and R50/5-R100RT, 7,15mm	2,94 €	3,50 €
S080A	31249	Spacer ring wheel bearing for BMW R25/3-R27 and R50/5-R100RT, 7,20mm	2,94 €	3,50 €
S080A	30781	Spacer ring wheel bearing for BMW R25/3-R27 and R50/5-R100RT, 6,30mm	2,94 €	3,50 €
S080B	38338	Spacer ring wheel bearing for BMW R50-R69S, 7,40mm	2,73 €	3,25 €
S080B	38331	Spacer ring wheel bearing for BMW R50-R69S, 7,05mm	2,52 €	3,00 €
S080B	38332	Spacer ring wheel bearing for BMW R50-R69S, 7,10mm	2,52 €	3,00 €
S080B	38333	Spacer ring wheel bearing for BMW R50-R69S, 7,15mm	2,52 €	3,00 €
S080B	38334	Spacer ring wheel bearing for BMW R50-R69S, 7,20 mm	2,52 €	3,00 €
S080B	38335	Spacer ring wheel bearing for BMW R50-R69S, 7,25mm	2,52 €	3,00 €
S080B	38336	Spacer ring wheel bearing for BMW R50-R69S, 7,30mm	2,52 €	3,00 €
S080B	38337	Spacer ring wheel bearing for BMW R50-R69S, 7,35mm	2,52 €	3,00 €
S080B	38330	Spacer ring wheel bearing for BMW R50-R69S, 7,00mm	2,52 €	3,00 €
S081B	38162	Wheel bearing retainer for BMW R26, R27 and R25/3 (ONLY 1955), for taper roller bearing zincked	9,71 €	11,55 €
S081C	38161	Wheel bearing retainer for BMW R26, R27 and R25/3 (ONLY 1955), for taper roller bearing stainless steel	22,44 €	26,70 €
S082A	38155	Felt ring for wheel bearing for BMW R25/2-R27 and R50/5-R75/5	2,23 €	2,65 €
S082B	38259	Felt ring for wheel bearing for BMW R50-R69S	2,10 €	2,50 €
S082C	38156	Felt ring for wheel bearing nut for BMW R50-R69S	2,27 €	2,70 €



S083A	38157	Felt ring cap wheel bearing for BMW R25/2-R27 and R50/5-R75/5	2,94 €	3,50 €
S083B	38255	Felt ring cap wheel bearing for BMW R51/2-R69S	3,19 €	3,80 €
S084	38267	Cover disc wheel bearing for BMW R50-R69S	1,60 €	1,90 €
S085	038143	Thrust sleeve for BMW R26 and R27, left side	7,98 €	9,50 €
S086A	91002	Hubcap for BMW R26 and R27 chromed	18,49 €	22,00 €
S086B	91001	Hubcap for BMW R26 and R27 silver painted	13,44 €	15,99 €
S086C	88002	Hubcap for BMW R50-R69S chromed	21,85 €	26,00 €
S086D	88001	Hubcap for BMW R50-R69S silver painted	15,13 €	18,00 €
S087	22083	Spring washer B10, DIN137A zincked	0,17 €	0,20 €
S088	38182	Screw for hub-cap for BMW R25/3-R68, M 6 stainless steel, wrench size 9mm	5,00 €	5,95 €
S088	38181	Screw for hub-cap for BMW R25/3-R68, M 6 chromed, wrench size 9mm	2,10 €	2,50 €
S089	38263	Lock washer for hubcap for BMW R50-R69S	1,89 €	2,25 €
S090B	94052	Handlebar for side car use, universal, flat 750mm wide, Fehling	41,51 €	49,40 €
S090B	4052	Handlebar for side car use for BMW R26, R27 and R50-R69S, original shape	29,58 €	35,20 €
S090C	72002	Handlebar (touring) medium high 95mm high, 670mm wide	27,73 €	33,00 €
S090D	5052	Handlebar half-high, similar to BMW R50/5, R60/5 and R75/5 145mm high, 765mm wide, Fehling, US-Version	48,82 €	58,10 €
S090DA	72036	Handlebar for BMW R50-R69S, half-high with cross bar 160mm high, 750mm wide, US-Version	42,69 €	50,80 €
S090E	72129	Handlebar for BMW R26, R27 and R50-R69S, original shape	28,15 €	33,50 €
S090F	3062	Handlebar, LN A 200mm high, 800mm wide, Fehling, REMNANTS	30,17 €	35,90 €
S090G	3063	Handlebar, LN B 250mm high, 830mm wide, Fehling	47,65 €	56,70 €
S091	72104	Handlebar riser for BMW R25/3, R26 and R27 stainless steel chromed	38,36 €	45,65 €
S091B	72306	Handlebar riser for BMW R50-R69S stainless steel	42,86 €	51,00 €
S092	72145	Screw for handlebar riser for BMW R25/3 and R26 chromed	9,03 €	10,75 €
S092	72146	Screw for handlebar riser for BMW R27 chromed	8,57 €	10,20 €
S092	72288	Screw for handlebar riser for BMW R50-R69S chromed	15,29 €	18,20 €
S092D	98351	Nut M 8 x 1, self-locking (lock nut) zincked	0,42 €	0,50 €
S093	30407	Handle bar rubber for BMW R24-R90S, in-house production, round, left side	4,62 €	5,50 €
S093	30868	Handle bar rubber for BMW R24-R90S, in-house production, round, right side	4,62 €	5,50 €
S093a	19152	Handle bar rubber for BMW R24-R90S, in-house production, round, pair	8,82 €	10,50 €
S093b	720850	Handle bar rubber for BMW R24-R90S, Magura, round, pair	16,72 €	19,90 €
S094A	30870	Clutch/brake lever bolt, early version, for BMW R25-R69S	2,23 €	2,65 €
S094B	38380	Clutch / brake lever bolt "new" version for BMW R50/5-R100 stainless steel	3,78 €	4,50 €
S094B	22174	Clutch/brake lever bolt for BMW R25-R69S stainless steel, polished	8,32 €	9,90 €
S096	30878	Cable adjustor screw M10 x 1 for BMW R60/6-R100, with slot	6,68 €	7,95 €
S096	39177	Throttle adjusting screw M 7 for BMW R26 and R27	3,19 €	3,80 €
S096	72221	Cable adjusting screw M 7 for BMW R26, R27 and R50-R69S	2,48 €	2,95 €
S096	30876	Cable adjustor screw for BMW R50/5, R60/5 and R75/5, WITHOUT slot	6,05 €	7,20 €
S097	11440	Nipple adaptor for BMW R26, R27, R50-R69S and for BMW R50/5-R90S on lever until year of manufacture 09/1975	5,63 €	6,70 €
S097B	30404	Nipple adaptor for BMW R25-R69S, Ø 8mm	4,12 €	4,90 €
S098	30877	Cable adaptor for BMW R50/5-R100 REMNANTS	3,28 €	3,90 €
S099	72371	Adjusting lever 1-cable black painted	26,47 €	31,50 €
S099	72361	Ignition retard lever for BMW R51/2 and R68, complete	55,38 €	65,90 €
S099b	110200	Adjusting lever, left side, mounting directly on handlebar	16,72 €	19,90 €
S100	7211301	Clutch control housing for BMW R26, R27 and R50-R69S WITHOUT thread for mirror	40,34 €	48,00 €
S100A	32980	Clutch control unit for BMW R50/5-R90S until year of manufacture 09/1974	114,12 €	135,80 €
S100A	2072425	Clutch control for BMW R26, R27 and R50-R69S complete WITHOUT thread for Mirror	73,95 €	88,00 €
S101	72219	Clamp screw, control housing for BMW R26, R27, R50-R69S and R50/5-R75/5	0,42 €	0,50 €
S102A	72225	Clutch lever for BMW R26, R27 and R50-R69S, pointed old version with wide intake	12,86 €	15,30 €
S102B	72254	Clutch lever for BMW R26, R27 and R50-R69S, pointed new version with narrow intake	12,86 €	15,30 €
S102C	72226	Clutch lever for BMW R26, R27 and R50-R69S, ball end	12,86 €	15,30 €
S103	72153	Throttle twist tube for BMW R26, R27 and R50-R69S and for BMW R50/5-R90S until year of manufacture 08/1974, steel	25,80 €	30,70 €
S104	25600	Throttle control unit "Sport", radial, 1 cable, 46mm stroke aluminum	77,48 €	92,20 €
S104	72223	Wedge for Magura throttle/clutch assy for BMW R26, R27, R50-R69S and R50/5-R90S	4,16 €	4,95 €
S104A	1232981	Throttle control unit for BMW R50/5-R90S, until year of manufacture 08/1974	159,41 €	189,70 €
S105A	72253	Brake lever for BMW R26, R27 and R50-R69S, blade typ old version, (wide)	12,86 €	15,30 €
S105B	72252	Brake lever for BMW R26, R27 and R50-R69S, ball type	12,86 €	15,30 €
S105C	11130	Brake control assembly, universal, Magura REMNANTS	32,69 €	38,90 €
S107	1232463	Throttle cam for BMW R50/5-R90S until year of manufacture 09/1974 brass	45,63 €	54,30 €
S107A	72265	Throttle cam for BMW R26 and R27 brass	41,35 €	49,21 €
S107B	72384	Throttle cam for BMW R50-R69S, brass	45,63 €	54,30 €
S108A	31461	Throttle control cover for BMW R50-R69S used	15,13 €	18,00 €



S109	72259	Screw for throttle cover for BMW R26, R27, R50-R69S and R50/5-R100 until year of manufacture 1981 stainless steel polished	6,18 €	7,35 €
S110	72147	Distance sleeve for handlebar for BMW R25/3 and R26	3,57 €	4,25 €
S110a	34227	Distance ring engine for BMW R51/3-R69S and handle bar for BMW R27	3,28 €	3,90 €
S111	72194	Handlebar mounting rubber for BMW R25/3 and R26	2,35 €	2,80 €
S113	98415	Large diameter washer, 8,4 x 24mm	0,13 €	0,15 €
S113	98432	Lock washer A 8, Form B zincked	0,08 €	0,10 €
S114	23420	Castle nut M 8x1 zincked, fine thread	1,51 €	1,80 €
S116	42495	Grommet for throttle cabel on handle bar, 1 cable, for BMW R26 and R27	3,11 €	3,70 €
S116	30037	Grommet for throttle cabel on handle bar, 2 cables for BMW R50/5-R100RT	2,69 €	3,20 €
S130	16009	Lock combination steering / toolbox for BMW R25/3 and R50-R69S	42,52 €	50,60 €
S131	317025	Steering lock for BMW R25/3-R27, R50-R69S and R50/5-R100, short	9,92 €	11,80 €
S132	5076	Lock for tool box for BMW R25/3 and R50-R69S	29,16 €	34,70 €
S201	2035	Clamp for rear mirror diameter rod 10mm	1,93 €	2,30 €
S202	2043	Rubber sleeve for lever, ball-end black	1,81 €	2,15 €
S203	1039	Rear Mirror for BMW, rectangular, with clamp for handlebar fits on both sides (1 piece)	14,28 €	16,99 €
S204A	3039	Rear Mirror for BMW, oval, with clamp, left side	13,44 €	15,99 €
S205A	4039	Rear Mirror for BMW, round, with clamp, left + right side stainless steel head	13,44 €	15,99 €
S205B	2014039	Rear Mirror for BMW, round, with clamp, left + right side one pair (2 mirrors) – universal	18,40 €	21,90 €
S206A	6039	Rear Mirror for BMW, oval, for bar end mounting, left side	19,24 €	22,90 €
S206A	0006039	Rear Mirror for BMW, oval, for bar end mounting, right side	19,24 €	22,90 €
S206B	6040	Rear Mirror for BMW, round, for bar end mounting, left side	18,49 €	22,00 €
S206C	0006041	Rear Mirror for BMW, round, for bar end mounting, right side	18,49 €	22,00 €
S207A	112520	Rear Mirror "Albert", left side	38,15 €	45,40 €
S207B	112521	Rear Mirror "Albert", right side	38,15 €	45,40 €
S301A	3055	Brake cable for BMW R24-R27 and R51/2-R67	7,14 €	8,50 €
S301AA	30551	Brake cable for BMW R24-R27 and R51/2-R67, 15cm longer for high or wide bars	7,14 €	8,50 €
S301AB	30552	Brake cable for BMW R24-R27 and R51/2-R67, 30cm longer for very high or very wide bars	7,14 €	8,50 €
S301AC	3411841	Brake cable for BMW R51/3-R68 DUPLEX from year of manufacture 1953	7,14 €	8,50 €
S301B	5055	Brake cable for BMW R50-R69S	6,81 €	8,10 €
S301C	50552	Brake cable for BMW R50-R69S, 15cm longer for high or wide bars	7,14 €	8,50 €
S301D	5055230	Brake cable for BMW R50-R69S, 30cm longer for very high or very wide bars	9,16 €	10,90 €
S302	70552	Throttle cable BLITZ-carburettor for BMW R25, R25/2 and R25/3	4,37 €	5,20 €
S302	70551	Throttle cable BLITZ-carburettor for BMW R26 and R27	4,37 €	5,20 €
S302A	7055	Throttle cable for BMW R25, R25/2, R26 and R27	4,37 €	5,20 €
S302AC	7056	Throttle cable for BMW R25, R25/2, R26 und R27, 15cm longer for high or wide bars	5,80 €	6,90 €
S302B	7054	Throttle cable for BMW R25/3	5,67 €	6,75 €
S302BB	7053	Throttle cable for BMW R25/3, 15cm longer for high or wide bars	5,80 €	6,90 €
S302C	72355	Throttle cable for BMW R51/2-R68	5,00 €	5,95 €
S302CB	72356	Throttle cable for BMW R51/2-R68, 15cm longer for high or wide bars	5,46 €	6,50 €
S302CC	72357	Throttle cable for BMW R51/2-R68, 30cm longer for very high bars	5,80 €	6,90 €
S302D	72348	Throttle cable for BMW R50-R69S, R50/5-R60/7 and R90S	4,96 €	5,90 €
S302DB	72349	Throttle cable for BMW R50-R69S, R50/5-R60/7 and R90S, 15cm longer for high or wide bars	4,96 €	5,90 €
S302DC	72350	Throttle cable for BMW R50-R69S, R50/5-R60/7 and R90S, 30cm longer for very high bars	4,96 €	5,90 €
S303A	72215	Clutch cable for BMW R25-R69S	6,30 €	7,50 €
S303B	72216	Clutch cable for BMW R25-R69S, 15cm longer for high or wide bars	6,51 €	7,75 €
S303C	72217	Clutch cable for BMW R25-R69S, 30cm longer for very high bars	7,52 €	8,95 €
S303D	70233	Gripper clamp, crossbar for BWM R24-R69S stainless steel	6,05 €	7,20 €
S400	4038220	Rim for BMW R50-R69S, motorcycle rear, Chrom, size 2.50x18 for M4x140mm spokes (for sidecar-use)	184,79 €	219,90 €
S400	038217	Rim für BMW R50-R69S, stainless steel polished for M4x140mm spokes (double crossed)	171,43 €	204,00 €
S400	4038217	Rim for BMW R50, R60, R69 and R69S, stainless steel polished for M4x116mm spokes (single crossed)	171,43 €	204,00 €
S400	4038114	Rim for BMW R25 and R25/2 stainless steel polished with special nipples	142,77 €	169,90 €
S400	4038116	Rim for BMW R25/3, R26 and R27 stainless steel polished	171,43 €	204,00 €
S400	38217	Rim for BMW R50, R60, R69 and R69S, TOP chrome quality for M4x116mm spokes (single crossed)	142,02 €	169,00 €
S400	38324	Rim for BMW R51/3-R68, full-hub, chrome for 4mm spokes	100,76 €	119,90 €
S400	38325	Rim for BMW R51/3-R68, full-hub, high shoulder, aluminum for 4mm spokes	201,60 €	239,90 €
S400	38212	Rim for BMW R50, R60 and R69, high shoulder, aluminium polished for M4x116mm spokes (single crossed)	211,01 €	251,10 €
S400	38211	Rim for BMW R50-R69S, high shoulder, aluminium polished for M4x140mm spokes (double crossed)	201,60 €	239,90 €
S400	38116	Rim for BMW R25/3, R26 and R27, high shoulder aluminium polished	184,79 €	219,90 €



S400	4071	Rim for BMW R25 and R25/2 - 36-hole-rim crude	91,60 €	109,00 €
S400	7071	Rim for BMW R25 and R25/2 Chrome	109,16 €	129,90 €
S400	2071	Rim for BMW R25/3, R26 and R27 chrome	120,67 €	143,60 €
S400	1071	Rim for BMW R50-R69S, TOP chrome quality for M4x140mm spokes (double crossed)	142,77 €	169,90 €
S400	5071	Rim for BMW R51/2-R68, semi hub, crude for 5mm spokes	92,35 €	109,90 €
S400B	8071	Rim for BMW R25 and R25/2 black/silver painted	159,62 €	189,95 €
S400G	3071	Rim for BMW R51/2-R68 semi-hub, chrome for 5mm spokes	100,76 €	119,90 €
S400GA	9071	Rim for BMW R51/2-R68, semi-hub, black/silver painted for 5mm spokes	155,00 €	184,45 €
S500	6044	Spoke for BMW R25/3-R27 and R50-R69S, R50/5 and up, rear, M4 x 140, (2x crossed) chromed, with nipple	1,01 €	1,20 €
S500	38226	Spoke for BMW R50-R69S, M4 x 116, (single crossed) stainless steel, with nipple	1,22 €	1,45 €
S500	21044	Spoke for BMW R50-R69S, M4 x 116, (single crossed) chromed, with nipple	1,01 €	1,20 €
S500	1047	Spoke for BMW R25/3-R27 and R50-R69S, R50/5 and up, rear, M4 x 140, (2x crossed) stainless steel, with nipple	1,22 €	1,45 €
S500A	99100	Spoking and centering job, wheel	80,00 €	95,20 €
S501	38107	Spoke for BMW R24, M3,5 x 165, short, rear chromed, cropped, with nipple	1,60 €	1,90 €
S501	038105	Spoke 18" side car, M3,5 x 200 with nipple	1,60 €	1,90 €
S501	0038107	Spoke for BMW R24, M3,5 x 173, short, front chromed, cropped, with nipple	1,26 €	1,50 €
S502A	38208	Spoke for BMW R51/3-R68, M3,5 x 125, full hub, thick end chromed, with nipple	1,93 €	2,30 €
S502B	8044	Spoke for BMW R51/3-R68, M4 x 125, full hub chromed, with nipple	1,01 €	1,20 €
S502C	8045	Spoke for BMW R51/3-R68, M4 x 125, full hub stainless steel, with nipple	1,22 €	1,45 €
S502D	25044	Spoke for BMW R51/2-R68, M5 x 127, half hub, short chromed, with nipple	1,01 €	1,20 €
S502F	5044	Spoke for BMW R51/2-R68, M5 x 127, half hub, short, thick end chromed, WITHOUT nipple	1,93 €	2,30 €
S502G	4044	Spoke for BMW R51/2-R68, M5 x 212, half hub, long, thick end chromed, WITHOUT nipple	1,93 €	2,30 €
S504	31044	Spoke for BMW R25/3 and R26 "old", M3,5 x 140 chromed, with nipple	1,85 €	2,20 €
S510	30069	Spoke nipple M4, Original Berg Union	0,38 €	0,45 €
S510A	30065	Spoke nipple M3,5	0,38 €	0,45 €
S510B	30070	Spoke nipple M4	0,34 €	0,40 €
S510Bb	0030070	Spoke nipple M4 stainless steel	0,42 €	0,50 €
S510C	30071	Spoke nipple M5	0,67 €	0,80 €
S520	15001	Spoke adaptor square	1,22 €	1,45 €
S521	97001	Spoke spanner for nipple M3 - M3,5 - M4 - M4,5 chrome vanadium	10,84 €	12,90 €
S521	9700101	Spoke spanner for nipple M3,5 - M4 - M4,5 - M5	9,66 €	11,50 €
S601	1040	Rim tape - Tube protection rubber suitable for 16 - 21 inch	2,35 €	2,80 €
S602A	2040	Tire air tube 3.25/3.50-18	9,92 €	11,80 €
S602B	20402	Tire air tube 3.25/3.50/4.00-19	13,19 €	15,70 €
S602C	20401	Tire air tube 4.00-18	11,35 €	13,50 €
S602E	20405	Tire air tube 3.00, 3.25, 3.50-17, Metzeler	15,08 €	17,95 €
S610A	232518	Tire 3.25-18, "house-brand", block profile for BMW R25/3, R26 and R27	44,45 €	52,90 €
S610B	233518	Tire 3.25S18, Heidenau, K34	81,51 €	97,00 €
S611A	240019	Tire 3.25H19, Heidenau, K44	73,95 €	88,00 €
S611C	732519	Tire 3.25-19, "house-brand", block profile for BMW R25 and R25/2	50,88 €	60,55 €
S612	130019	Tire 3.00-19, Mitas, H-01 e.g. for BMW R24	41,93 €	49,90 €
S612A	150019	Tire 3.00-19, Metzeler, Block C for BMW R24	83,95 €	99,90 €
S612A	132519	Tire 3.50S19, Avon, AM6, Speedmaster for BMW R51/2-R68, classical groove profile, for front wheel	83,99 €	99,95 €
S613A	135018	Tire 3.50-18, "house-brand", block profile for BMW R50-R60/2	50,97 €	60,65 €
S613B	635018	Tire 3.50S18, Metzeler, Block C for BMW R50-R69S	92,35 €	109,90 €
S613C	435018	Tire 3.50S18, Heidenau, K34 for BMW R50-R69S	75,59 €	89,95 €
S614B	235019	Tire 3.50-19, "house-brand", block profile for BMW R51/2-R68	58,74 €	69,90 €
S614C	335019	Tire 3.50-19, Avon, sidecar	92,35 €	109,90 €
S615A	335018	Tire 3.50S18, Metzeler, ME77 for BMW R50-R69S	83,95 €	99,90 €
S615B	535018	Tire 3.50S18, Metzeler, ME77, for front wheel for BMW R50-R69S	83,61 €	99,50 €
S616A	140018	Tire 4.00-18, Metzeler, Block K for BMW R50-R69S	109,16 €	129,90 €
S616B	640018	Tire 4.00-18, "house-brand" for BMW R50-R69	58,74 €	69,90 €
S616C	740018	Tire 4.00H18, Metzeler, Block C66 Touring Special	109,16 €	129,90 €
S616C	0112018	Tire 4.00H18, Heidenau, K36	109,24 €	130,00 €
S617A	540018	Tire 4.00S18, Mitas, H-06	67,14 €	79,90 €
S618	832519	Tire 3.25H19, Metzeler, ME33, Lasertec, for front wheel	117,56 €	139,90 €
S618A	140019	Tire 4.00-19, Mitas, H-02 for BMW R51/2-R68	71,43 €	85,00 €
S999	98009	Spokes ballance weight, 30gr	2,14 €	2,55 €
S999	98006	Spoke Ballance weight, 10gr	1,22 €	1,45 €
S999	98008	Spokes ballance weight, 20gr	1,26 €	1,50 €
S999	98007	Spokes ballance weight, 15gr	1,26 €	1,50 €



Group F: Frame, fenders, tank, seats all models 1948-1956

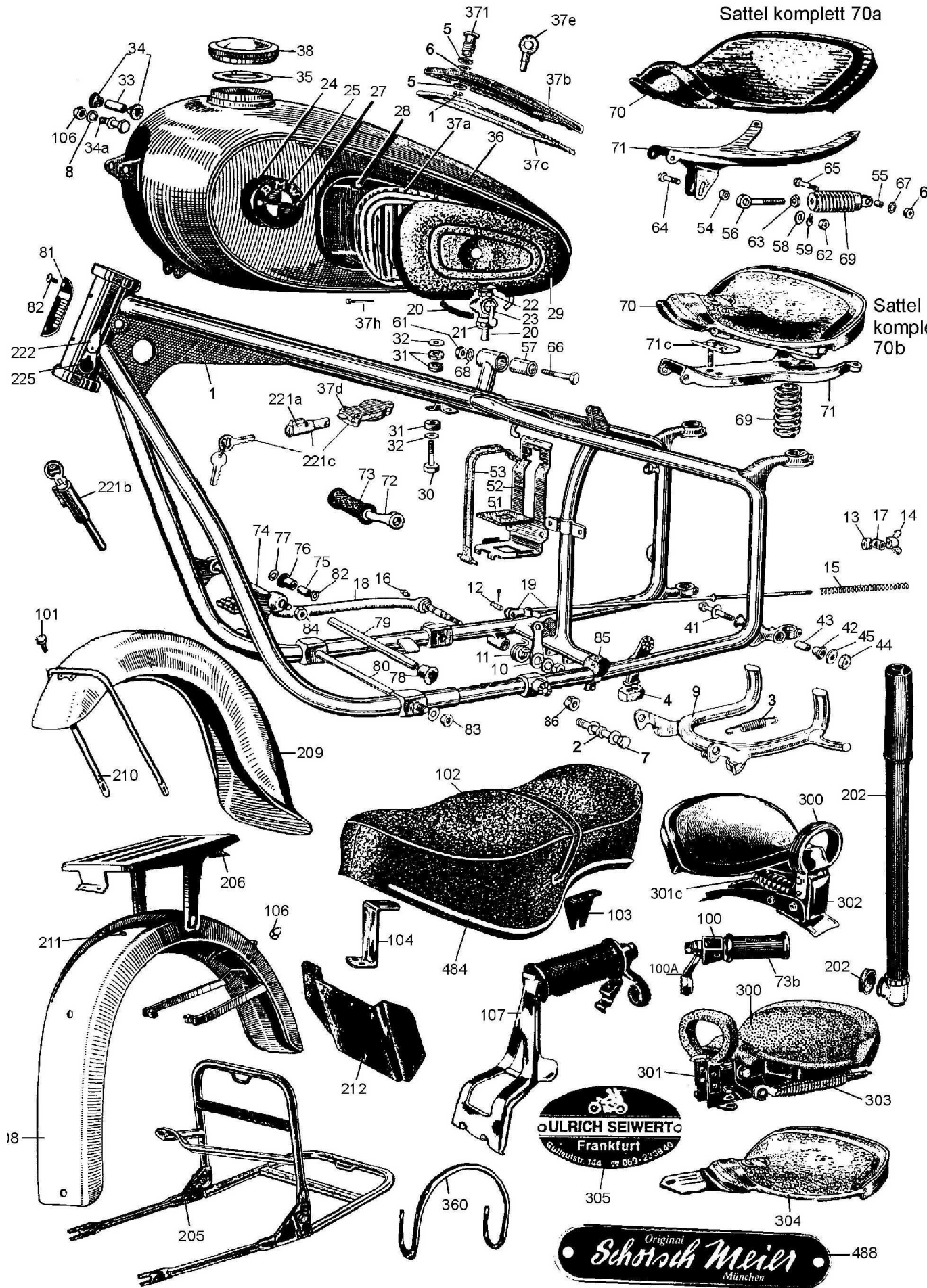



<u>Picture-No.</u>	<u>Article-No.</u>	<u>Description</u>	<u>Net</u>	<u>Gross</u>
F00	1303017	Fuel hose quick-connector, Ø 7,5mm	7,52 €	8,95 €
F00	1403017	Fuel hose quick-connector, Ø 9mm NOT for BMW-oldtimer-motorcycle	7,52 €	8,95 €
F000	4634260	Foot rest driver for BMW R51/2-R68 and R50-R69S, right side, long	25,13 €	29,90 €
F000	03017	Fuel hose tube	0,42 €	0,50 €
F000	4634125	Foot rest driver for BMW R51/2-R68 and R50-R69S, left side, short	25,13 €	29,90 €
F000	80007	Lock ring pet cock for BMW R25-R69S	0,21 €	0,25 €
F000	02181	Frame for Denfeld and Pagusa seat cover	28,36 €	33,75 €
F000	70134	Cable clamp, tail light cable for BMW R25	0,17 €	0,20 €
F000	9024160	Crash bar for BMW R51/3-R68, "Hoske"-shape, stainless steel polished complete with mounting parts	117,56 €	139,90 €
F000	9988011	Hollow bolt fuel cock, M10x1 hose connector "Frankfurter Hahn"	4,12 €	4,90 €
F001	07161	Lock ring for tool box screw for BMW R24-R25/2, R26, R27 and R51/2-R68	0,29 €	0,35 €
F002	28130	Center stand bushing for BMW R25-R27 hardened	4,24 €	5,05 €
F003	28116	Spring center stand for BMW R25 and R25/2, lateral	4,54 €	5,40 €
F003A	28118	Spring center stand for BMW R25/3-R27 and R25/2 middle mounting	2,98 €	3,55 €
F003B	28216	Spring center stand for BMW R51/2-R68	3,36 €	4,00 €
F003C	28103	Flat spring for center stand for BMW R24 and R25	15,04 €	17,90 €
F004	28135	Center stand stopper for BMW R25-R69S and swing arm bumper and kickstarter stopper for BMW R27	2,35 €	2,80 €
F005	63073	Gasket ring toolbox screw, M10x14x1.5	0,21 €	0,25 €
F006	63108	O-ring tool box lock screw for BMW R24, R25, R25/2, R26, R27 and R51/2-R68	0,34 €	0,40 €
F007	28266	Screw for center stand for BMW R51/2, M10 x 110, hexagon with shaft	1,64 €	1,95 €
F007	14665	Screw for center stand for BMW R25-R27, M12 x 80	1,47 €	1,75 €
F007C	28262	Bolt center stand for BMW R51/2-R68 with 2 washers bushing and splint, Nirosta	10,59 €	12,60 €
F009A	4080	Center stand for BMW R25/3	99,16 €	118,00 €
F009B	1080	Center stand for BMW R51/2-R68, narrow version also for pre-war models BMW R51-R71	92,31 €	109,85 €
F009Ba	0006604	Center stand for BMW R51/3-R68, wide version	96,60 €	114,95 €
F009C	28004	Center stand for BMW R25	104,79 €	124,70 €
F009D	28010	Center stand for BMW R25/2, for sidewise spring	101,26 €	120,50 €
F009DA	28011	Center stand for BMW R25/2, for middle spring	100,42 €	119,50 €
F010B	44250	Link, foot brake pedal for BMW R51/3-R68	15,04 €	17,90 €
F011	44125	Spring for foot brake pedal for BMW R25, R25/2 und R25/3	7,52 €	8,95 €
F011A	44218	Spring for foot brake pedal for BMW R51/2-R68	5,80 €	6,90 €
F012A	40395	Brake rod bolt for BMW R26-R27 and R50-R69S, 8mm stainless steel polished	4,35 €	5,18 €
F012B	34961	Brake rod bolt with lock spring, 6x12mm	2,44 €	2,90 €
F012C	044129	Brake rod bolt for BMW R25-R25/3 and R51/2-R68, 8mm stainless steel polished	4,96 €	5,90 €
F012C	36226	Split pin 2,0 x 32	0,13 €	0,15 €
F012Ca	44136	Split pin for brake rod stainless steel	0,13 €	0,15 €
F013	44133	Brake rod ring, vaulted stainless steel polished	3,83 €	4,56 €
F014a	4044115	Wing nut for brake rod for BMW R25-R69S stainless steel chromed	10,84 €	12,90 €
F015	44138	Brake rod spring stainless steel polished	3,49 €	4,15 €
F016	38133	Grease port, M6x0,75x5, wrench size 7, fine thread	2,44 €	2,90 €
F017A	44230	Brake rod bolt, 14mm stainless steel polished	3,07 €	3,65 €
F017B	44231	Brake rod bolt with angle metal for brakelight for BMW R51/3-R68	11,85 €	14,10 €
F018	44027	Bolt for foot brake pedal for BMW R51/2-R68	32,02 €	38,10 €
F018	98421	Washer M10, DIN125/A2 stainless steel	0,17 €	0,20 €
F018	98420	Washer M10, DIN125, Form A cined	0,08 €	0,10 €
F018A	4044026	Foot brake pedal for BMW R51/2-R68	83,95 €	99,90 €
F019A	45090	Brake rod head, round for 8mm bolts stainless steel	9,71 €	11,55 €
F019B	44137	Brake rod head, square-shape for 6mm bolt stainless steel polished	14,83 €	17,65 €
F019D	44123	Brake rod for BMW R25 and R25/2, complete stainless steel	41,60 €	49,50 €
F019E	44124	Brake rod for BMW R25/3 complete stainless steel	45,46 €	54,10 €
F019F	44220	Brake rod for BMW R51/2-R68 complete stainless steel	47,48 €	56,50 €
F019G	45115	Brake light switch flat spring for BMW R25-R25/3	3,53 €	4,20 €
F020A	33366	Pet cock fuel line adaptor (single) with fine sieve, plastic	2,35 €	2,80 €
F020AA	99880	Pet cock fuel line adaptor (single) for "Frankfurter Modell"	7,23 €	8,60 €
F020B	84178	Pet cock fuel line adaptor (double) Karcoma REMNANTS	5,80 €	6,90 €
F020B1	9984178	Gasket ring fuel cock tap hose connection 2-fold Karcoma	0,25 €	0,30 €
F020BA	99881	Pet cock fuel line adaptor (double) for "Frankfurter Modell"	7,52 €	8,95 €
F020C	33368	Pet cock sieve in hose connector	2,10 €	2,50 €
F021A	84169	Pet cock nut, left/right threat buttom for double outlet	1,51 €	1,80 €
F021B	33369	Pet cock coupling nut, buttom for hose connector with 1 outlet	1,01 €	1,20 €
F021C	99940	Pet cock threat for weld-in tank for pet cock with M16x1 threat	10,84 €	12,90 €
F022	63077	Gasket ring fuel cock for small threads, M14 Frankfurter Armaturenwerke	0,63 €	0,75 €
F022A	84120	Pet cock nut for R25/3-R69S M16x1 left-hand thread , M20x1 right-hand thread	2,77 €	3,30 €
F022B	84121	Pet cock nut for BMW R25 and R25/2 M16x1 left-hand and right-hand thread	1,48 €	1,76 €



F022B	99908	Pet cock sieve in tank for BMW R24-R69S Inner Ø: 9mm, outer Ø: 10,3mm, length: 60mm	2,27 €	2,70 €
F022C	40060	Gasket ring fuel cock/tank for BMW R25/3-R69S and R50/5-R100 for all fuel cocks with connection M20x1	0,66 €	0,79 €
F023	84008	Pet cock for R25/3-R27, R50/5-R75/5, R60/6-R90S, with 1 outflow/leaving, "Everbest" ORIGINAL-FORM "EVERBEST"	41,93 €	49,90 €
F023	4084030	Pet cock for R51/3-R69S, with 2 outflow/leaving, "Everbest" ORIGINAL-FORM "EVERBEST"	44,12 €	52,50 €
F023	84031	Pet cock for BMW R51/3-R69S, with 2 outflow/leaving with drain-pool	36,89 €	43,90 €
F023	08008	Pet cock for BMW R25/3-R27 and R50/5-R100 WITH drain-pool	36,89 €	43,90 €
F023	84030	Pet cock for BMW R51/3-R69S, with 2 outflow/leaving	32,69 €	38,90 €
F023	80008	Pet cock for BMW R25/3-R27 and R50/5-R75/5, with 1 outflow/leaving	28,53 €	33,95 €
F023B	80004	Pet cock for BMW R25 and R25/2, small threat including gasket	23,11 €	27,50 €
F023D	80001	Pet cock for BMW R24 for tanks with internal screw thread, M14x1,5 WITHOUT drain-pool	23,11 €	27,50 €
F023E	40512	Pet cock gasket (Kork) for Kakoma-petcock	2,69 €	3,20 €
F023F	78070	Pet cock for BMW R35 and other PRE WW2-models, 1/4 inch WITH drain-pool	33,53 €	39,90 €
F023F	08001	Pet cock for BMW R24 for tanks with internal screw thread, M14x1,5 WITH drain-pool	34,96 €	41,60 €
F023G	08004	Pet cock for BMW R25 and R25/2, small thread with drain-pool	32,52 €	38,70 €
F023I	84025	Pet cock for BMW R51/2, with 2 outflow/leaving, internal thread WITH drain-pool	34,54 €	41,10 €
F023i	1240512	Cork gasket for original Everbest-pet cock, cylindrical	6,64 €	7,90 €
F023N	4084115	Sieve with cage for Everbest pet cock original BMW, REMNANTS	21,01 €	25,00 €
F024A	12001	Emblem rubber for BMW R24-R69S	1,51 €	1,80 €
F024B	99012	Emblem collar for BMW R24-R69S for enamel emblem Ø=60mm, stainless steel	14,20 €	16,90 €
F025	0035269	Emblem for BMW R25/3-R27, R51/2-R68 and R50-R69S, "old letters", Tank original BMW	43,78 €	52,10 €
F025	0035322	Emblem for BMW R25/3, R26 and R27, "old letters", tank original BMW	43,78 €	52,10 €
F027	1038	Emblem screw for BMW R25/2-R69S stainless steel	0,34 €	0,40 €
F027a	9910381	Emblem screw for BMW R24-R69S, cross-slot stainless steel	0,38 €	0,45 €
F028	800021	Knee pad holder for BMW R25/3, left side (weld on)	11,68 €	13,90 €
F028	800022	Knee pad holder for BMW R25/3, right side (weld on)	11,68 €	13,90 €
F028A	8014525	Knee pad holder for BMW R25, R25/2 and R51/3-R68 (weld on)	10,80 €	12,85 €
F028B	80145	Knee pad holder set for BMW R25, R25/2 and R51/3-R68 2 pieces	21,01 €	25,00 €
F029A	79116	Knee pad for BMW R20, R23 and R24, right and left side (article is 1 pair = 2 pc.)	43,61 €	51,90 €
F029B	80184	Knee pad for BMW R25, R25/2, and R51/3-R68, both sides are the same (single = 1 pc.)	14,83 €	17,65 €
F029C	80185	Knee pad for BMW R25/3, only left side (with hole) (single = 1 pc.)	18,91 €	22,50 €
F029D	80186	Knee pad for BMW R25/3, only right side (single = 1 pc.)	18,91 €	22,50 €
F029E	80250	Knee pad for BMW R51/2, right and left side, (also PRE WW2 R51, R71, R75) (article is 1 pair = 2 pc.)	33,61 €	40,00 €
F029F	6009	Knee pad for "Hoske"-tank, left and right (article is 1 pair = 2 pc.)	50,34 €	59,90 €
F030	14050	Fuel tank holder screw M 8 x 1 x 30, hexagon, for BMW R25/2-R69S, rear also for seat spring	0,59 €	0,70 €
F031	3008	Fuel tank holder rubber for BMW R25/2-R69S, rear	1,26 €	1,50 €
F033	80178	Distance sleeve for tank for BMW R25/3, front	4,12 €	4,90 €
F034	14005	Fuel tank holder screw M 8 x 1 x 16, hexagon for BMW R51/3-R68, front	0,42 €	0,50 €
F034	98219	Fuel tank holder screw M 8 x 1 x 70 for BMW R25, R25/2 and R25/3, front	1,26 €	1,50 €
F034	80137	Fuel tank holder rubber for BMW R25/3, R26 and R27, front, conical	1,85 €	2,20 €
F035	3053	Gasket for fuel tank cap from BMW R24-R69S	1,51 €	1,80 €
F036	61030	Fuel tank for BMW R25/2, new painted and stripped (refurbished)	823,53 €	980,00 €
F036	58030	Fuel tank for BMW R25/3, new painted and stripped (refurbished)	689,07 €	819,99 €
F036	80003	Fuel tank for BMW R24 and R25, new painted and stripped (refurbished)	823,53 €	980,00 €
F036	0058030	Fuel tank for BMW R25/3, raw Replica	383,61 €	456,50 €
F036	0035285	Fuel tank for BMW R25/3, new painted and stripped (refurbished) for luggage rack use	773,11 €	920,00 €
F036A	035288	Fuel tank for BMW R51/3-R68, primed Replica	630,25 €	750,00 €
F036B	35288	Fuel tank for BMW R51/3-R68, primed original BMW, NEW	1.605,38 €	1.910,40 €
F036C	35289	Fuel tank for BMW R51/3-R68, painted and stripped original BMW, NEW	1.638,66 €	1.950,01 €
F036D	035289	Fuel tank for BMW R51/3-R68, new painted and stripped Replica	1.134,45 €	1.350,00 €
F037	80288	Gasket tool box for BMW R25/3 and R50-R69S	2,48 €	2,95 €
F037	47463	Bolt for tool box cover for BMW R25/3 and R50-R69S for tool compartment laterally	2,48 €	2,95 €
F037	80168	Tool box cover for BMW R25 and R51/2-R68 opens sideways	61,26 €	72,90 €
F037	80188	Gasket tool box for BMW R24-R25/2, R26, R27 and R51/3-R68, tank above	5,00 €	5,95 €
F037	5076	Lock for tool box for BMW R25/3 and R50-R69S	29,16 €	34,70 €
F037	31298	Tool box cover for BMW R25/2, R26, R27, R51/3-R68, R65 and R50/5-R100 police model, opens lengthways	40,97 €	48,75 €
F037	80166	Tool box cover for BMW R25/3, new, with knee pad holder grounded, has to be adapted!	54,54 €	64,90 €
F037	41016	Key for tool box, square-end for BMW R24-R25/2, R26, R27 and R51/2-R68 also battery cover key for BMW R26 and R27	3,78 €	4,50 €



F037	4080176	Bolt for tool box cover for BMW R24-R25/2, R26, R27 und R51/2-R68 for tool compartment cover above, stainless steel	3,78 €	4,50 €
F037AA	0035313	Luggage carrier on fuel tank for BMW R25/3 chromed	96,60 €	114,95 €
F037G	80191	Rubber buffer for tool box for BMW R25/3	1,85 €	2,20 €
F038	1053	Fuel tank cap for BMW R24-R69S, lockable, with lock cover with rubber gasket, stainless steel polished	14,33 €	17,05 €
F038A	1001053	Fuel tank cap for BMW R24-R69S, lockable, WITHOUT lock cover with rubber gasket, stainless steel polished	14,24 €	16,95 €
F038B	80126	Fuel tank cap for BMW R24-R69S, NOT lockable with rubber gasket, aluminum	12,23 €	14,55 €
F038C	1180126	Fuel tank cap for BMW R24-R69S, NOT lockable with rubber gasket, chromed	12,23 €	14,55 €
F041	098207	Screw M 8 x 45, hexagon with shaft stainless steel	0,46 €	0,55 €
F041	98207	Screw M 8 x 45, hexagon with shaft	0,25 €	0,30 €
F042	80138	Exhaust mounting rubber for BMW R25/3 and R26	1,85 €	2,20 €
F043	90130	Distance sleeve for muffler holder for BMW R25/3	3,36 €	4,00 €
F044	98415	Large diameter washer, 8,4 x 24mm	0,13 €	0,15 €
F051A	42109	Battery support (foam rubber) for BMW R24-R25/3, R51/2-R69S 74x88 mm	2,14 €	2,55 €
F051B	42211	Battery support (foam rubber) for 6V16Ah battery, foam rubber, for BMW R50-R69S US-Version 80x115mm	2,98 €	3,55 €
F052A	42121	Battery carrier for BMW R25, R25/2 and R25/3 powdercoated, black	33,61 €	40,00 €
F053A	30016	Battery strap for BMW R24-R25/3, R50-R69S rubber 250mm	4,87 €	5,80 €
F053B	32016	Battery strap for BMW R51/3-R68 from year of manufacture 09/1953 rubber 270mm, "short version"	4,87 €	5,80 €
F053C	29016	Battery strap for BMW R51/2-R68, until year of manufacture 09/1953 rubber 350mm, "long version"	4,87 €	5,80 €
F057A	02125	Seat mounting bolt set 3-pieces for BMW R25, R25/2 and R51/3-R68 until year of manufacture 09/1953 stainless steel	19,24 €	22,90 €
F057B	92141	Silent block seat carrier for BMW R50 and R51/3-R68 from year of manufacture 1954 and seat adapter for BMW R25/3-R27	9,20 €	10,95 €
F061	98362	Nut M10 zincked	0,20 €	0,24 €
F064	14050	Fuel tank holder screw M 8 x 1 x 30, hexagon, for BMW R25/2-R69S, rear also for seat spring	0,59 €	0,70 €
F066	14364	Screw M10 x 1 x 70, hexagon with shaft	1,26 €	1,50 €
F068	98420	Washer M10, DIN125, Form A cined	0,08 €	0,10 €
F069A	021020	Seat spring driver seat for BMW R25/2-R68 chrome-plated	15,21 €	18,10 €
F069B	02102	Seat spring for BMW R25/2-R27 and R51/2-R68 chrome-plated	53,36 €	63,50 €
F069C	02109	Seat spring driver seat for BMW R25 chrome-plated	21,47 €	25,55 €
F070	9906042	Seat top WITHOUT inner frame from BLITZ for BMW R25-R69S for driver and passenger seat	41,18 €	49,00 €
F070	9996042	Seat top WITH inner frame from BLITZ for BMW R25-R69S for driver and passenger seat	74,71 €	88,90 €
F070	0200942	Driver's seat for BMW R25/2-R68, R26 and R27 complete BLITZ	142,86 €	170,00 €
F070	0200601	Driver's seat for BMW R25 complete BLITZ	142,86 €	170,00 €
F070	1009066	Seat cover leatherette for solo and passenger saddle, for BMW R25-R69S, black with white welting	40,34 €	48,00 €
F070A	7002010	Seat top for BMW R24 WITHOUT inner frame, DRILASTIC also for BMW R20 and R23	134,37 €	159,90 €
F070AA	02009	Driver's seat for BMW R25/2-R68, R26 and R27 complete Pagusa	157,90 €	187,90 €
F070AB	02179	Driver's seat for BMW R25/2-R68, R26 and R27 complete Denfeld	187,06 €	222,60 €
F070BA	02005	Driver's seat for BMW R25 complete Denfeld	170,00 €	202,30 €
F070BB	02006	Driver's seat for BMW R25 complete Pagusa	151,18 €	179,90 €
F070C	02011	Seat top WITH inner frame from Denfeld for BMW R25-R69S, black for driver and passenger seat	102,27 €	121,70 €
F070D	02012	Seat top WITH inner frame from Pagusa for BMW R25-R69S for driver and passenger seat	80,59 €	95,90 €
F070E	1003	Seat top WITHOUT inner frame from Denfeld for BMW R25-R69S, black for driver and passenger seat	68,32 €	81,30 €
F070EA	91003	Seat top WITHOUT inner frame from Denfeld for BMW R25-R69S, white for driver and passenger seat	84,45 €	100,50 €
F070F	10030	Seat top WITHOUT inner frame from Pagusa for BMW R25-R69S for driver and passenger seat	46,18 €	54,95 €
F071A	02116	Seat carrier driver seat for BMW R25/2-R68	53,70 €	63,90 €
F071B	02117	Seat carrier driver seat for BMW R25	75,21 €	89,50 €
F071C	36205	Holding angle for seat for BMW R25-R68 2 holes mounting	5,55 €	6,60 €
F072	34153	Foot rest driver for BMW R25-R27 and for passenger for BMW R25-R27, R50-R69S stiff	15,13 €	18,00 €
F073A	34107	Footrest rubber for BMW R25-R90/6, round/stiff	5,00 €	5,95 €
F073B	10007	Footrest rubber for BMW R25-R27 and R50-R69S, oval shape	5,00 €	5,95 €
F074A	39030	Engine axle for BMW R25 and R25/2, upper stainless steel	7,48 €	8,90 €
F074B	39032	Engine axle for BMW R25/3 and R26, upper	14,20 €	16,90 €
F074C	34216	Engine axle for BMW R51/3-R69S, front stainless steel	10,04 €	11,95 €
F075	34170	Distance sleeve for engine for BMW R25/3 and R26, upper	3,28 €	3,90 €
F076	34166	Engine mounting rubber for BMW R25/3 and R26, upper	2,48 €	2,95 €
F078	34119	Engine mounting rubber for BMW R25/3 and R26, lower	3,32 €	3,95 €
F079A	01109	Distance sleeve for engine for BMW R25/3 and R26, lower	8,36 €	9,95 €



F079B	2072125	Stabiliser for Clutch cable holder for BMW R25 original BMW - REMNANTS	10,88 €	12,95 €
F080	7705704	Spacer ring engine for BMW R25 and R25/2, lower used	2,10 €	2,50 €
F080A	34113	Engine axle for BMW R25, R25/2, R25/3 and R26, lower	9,96 €	11,85 €
F080B	34210	Engine axle for BMW R51/3-R69S, rear	9,20 €	10,95 €
F081	2037	Identification plate BMW "neutral" for BMW R25-R69S	3,36 €	4,00 €
F081	4034139	Identification plate for BMW R25/2	11,68 €	13,90 €
F081	4034140	Identification plate for BMW R25/3	11,68 €	13,90 €
F081	4034240	Identification plate for BMW R51/3	11,85 €	14,10 €
F081	4034241	Identification plate for BMW R67, R67/2 and R67/3	11,68 €	13,90 €
F081	4034244	Identification plate for BMW R68	11,85 €	14,10 €
F082	9916604	Screw for identification plate, round head for BMW R24-R69S stainless steel	2,94 €	3,50 €
F083B	98377	Nut M12 x 1,5, flat stainless steel	2,10 €	2,50 €
F084A	22122	Nut M10 x 1 zincked	0,34 €	0,40 €
F085B	25116	Kick starter bumper for BMW R24-R26	7,35 €	8,75 €
F085B	26016	Kick starter bumper for BMW R51/2-R69S	8,19 €	9,75 €
F086A	98376	Nut M12 x 1,75 zincked	0,55 €	0,65 €
F086B	98372	Nut M12 x 1,75, self-locking zincked	0,63 €	0,75 €
F086C	98380	Nut M12 x 1,75 stainless steel	1,81 €	2,15 €
F100	34150	Foot rest passenger for BMW R25-R27 and R50-R69S, flip-up, oval-shape	23,53 €	28,00 €
F100A	0034261	Foot rest holder for BMW R24-R27 and R50-R69S, cropped, 10,3mm-Hole for flip-ups, rough teethed	6,64 €	7,90 €
F100B	0034262	Foot rest holder for BMW R24-R27, for Akipp stand mount short, rough teethed, cropped, 12,5mm-Hole	6,64 €	7,90 €
F100C	1034262	Foot rest holder for BMW R51/2-R69S, for Akipp stand mounting long, finely tooth, 12,5mm-Hole	6,64 €	7,90 €
F101	13222	Screw for fender brace for BMW R25-R69S stainless steel polished	2,23 €	2,65 €
F102A	34022	Dual seat for BMW R25-R69S original Denfeld	363,36 €	432,40 €
F102B	34021	Dual seat for BMW R25-R69S Reproduction	197,44 €	234,95 €
F102C	02007	Seat pad sport "Denfeld" for BMW R24-R69S, rear	289,41 €	344,40 €
F102D	0200701	Mounting kit for seat "Denfeld" for BMW R24-R69S for mounting on fender	19,41 €	23,10 €
F102D	7002007	Seat pad sport for BMW R24-R69S, "Denfeld-form" only for mouting DIRECTLY on fender	125,97 €	149,90 €
F102E	0200702	Mounting kit for seat "Denfeld" for BMW R24-R69S for mounting on luggage rack	19,24 €	22,90 €
F102E	7002008	Seat pad sport for BMW R24-R69S, "Denfeld-form" ONLY for mounting on luggage rack	130,00 €	154,70 €
F103	13463	Dual seat holder bracket for BMW R50-R69S, rear lateral ear	8,19 €	9,75 €
F104	13457	Dual seat holder bracket for BMW R50-R69S, front, Z-shape	10,00 €	11,90 €
F104	9034117	Dual seat holder bracket for BMW R24-R68, front	10,00 €	11,90 €
F106	96152	Cap nut M 8 for rear fender chromed	2,73 €	3,25 €
F107	90240	Side stand fit to footrest for BMW R51/2-R69S "Akipp", with all parts	79,79 €	94,95 €
F107	25013	Side stand for BMW R25, R25/2 and R25/3 black	82,35 €	98,00 €
F107	0024040	Side stand for BMW R26 black	82,35 €	98,00 €
F107a	2404551	Side stand for BMW R51/3-R68 complete, pre-installed, stainless steel	109,20 €	129,95 €
F107A	9024001	Side stand fit to footrest for BMW R25-R27 "Akipp", with all parts	79,79 €	94,95 €
F200	99993	Fuel-filter with paper inlay, stick-in-hose, universal, transparent	2,35 €	2,80 €
F201A	3017	Fuel hose, oldtime-look, per meter	4,08 €	4,86 €
F201A	3017713	Fuel hose, rubber-look, per meter	5,46 €	6,50 €
F202	1050	Tire air pump for BMW R25-R69S, black	15,42 €	18,35 €
F202	10501	Tire air pump for BMW R25-R69S, silver	15,42 €	18,35 €
F202B	90172	Dust cap for tire air pump	0,50 €	0,60 €
F202D	90176	Rubber gasket for tire air pump	1,09 €	1,30 €
F202E	90170	Tire air pump valve breather	0,67 €	0,80 €
F202F	90174	Rubber back-pressure valve for tire air pump	0,42 €	0,50 €
F202H	0010502	Tire air pump for BMW R25-R69S, chromed	21,43 €	25,50 €
F205	96216	Luggage rack for BMW R24-R69S, original shape, foldaway chromed	83,11 €	98,90 €
F206A	96101	Luggage grid for BMW R24	115,88 €	137,90 €
F206B	96103	Luggage grid for BMW R25 and R51/2	79,75 €	94,90 €
F206D	96100	Luggage grid for BMW R25/3	90,84 €	108,10 €
F206E	96210	Luggage grid for BMW R25/2 and R51/3-R68	79,75 €	94,90 €
F207	14005	Fuel tank holder screw M 8 x 1 x 16, hexagon for BMW R51/3-R68, front	0,42 €	0,50 €
F208	89030	Fender for BMW R25, rear painted and lined, replica	630,25 €	750,00 €
F208	0089030	Fender for BMW R25, rear crude, replica	419,33 €	499,00 €
F208	0090029	Fender for BMW R25/2, rear crude, replica	419,33 €	499,00 €
F208A	35297	Fender for BMW R51/2-R68, rear ground coat, original BMW new part	880,67 €	1.048,00 €
F208A	89050	Fender for BMW R25/3, rear crude, replica	411,68 €	489,90 €
F208B	35298	Fender for BMW R51/2-R68, rear painted and lined, original BMW new part	1.159,66 €	1.380,00 €
F208b	89040	Fender for BMW R25/3, rear painted and lined, replica	571,43 €	680,00 €
F208b	90029	Fender for BMW R25/2, rear painted and lined, replica	525,00 €	624,75 €



F208C	96018	Fender for BMW R51/2-R68, rear crude, replica	419,33 €	499,00 €
F208C	0035293	Fender for BMW R25/3, rear ground coat, original BMW new part	961,68 €	1.144,40 €
F208D	96038	Fender for BMW R51/2-R68, rear painted and lined, replica	516,72 €	614,90 €
F208D	9614902	Fender badge "R67/2" chromed	25,63 €	30,50 €
F208E	5096118	Hinge pin for rear fender of BMW R25-R69S, stainless steel	2,14 €	2,55 €
F208E	9614901	Fender badge "R51/3" chromed	25,63 €	30,50 €
F209A	35305	Fender for BMW R51/3-R67/3, front (Mudguard) ground coated, original BMW new part	647,06 €	770,00 €
F209A	90030	Fender for BMW R25, front (Mudguard) painted and lined, replica	521,01 €	620,00 €
F209B	71030	Fender for BMW R51/3-R67/3, front (Mudguard) crude, replica	377,31 €	449,00 €
F209C	71031	Fender for BMW R51/3-R67/3, front (Mudguard) painted and lined, replica	668,07 €	795,00 €
F209D	0035301	Fender for BMW R25/3, front (Mudguard) ground coat, original BMW new part	462,10 €	549,90 €
F209D	35306	Fender for BMW R51/3-R67/3, front (Mudguard) painted and lined, original BMW new part	914,45 €	1.088,20 €
F209E	0035302	Fender for BMW R25/3, front (Mudguard) painted and lined, original BMW new part	570,59 €	679,00 €
F209E	0000765	Fender for BMW R68, front (Mudguard) ground coat, original BMW new part	378,15 €	450,00 €
F209F	5090030	Fender for BMW R68, front (Mudguard) painted and lined, original BMW new part	546,22 €	650,00 €
F209F	35302	Fender for BMW R25/3, front (Mudguard) painted and lined, replica	521,01 €	620,00 €
F209F	90028	Fender for BMW R25/2, front (Mudguard) painted and lined, replica	521,01 €	620,00 €
F209G	0090028	Fender for BMW R25 and R25/2, front (Mudguard) crude, replica	260,42 €	309,90 €
F209G	5500001	Rubber pad between fender and brace for BMW R25, R25/2 and R25/3 VIBRATION PROTECTION	1,85 €	2,20 €
F210	32035	Fender brace for BMW R25/3 chrome-plated	19,45 €	23,15 €
F210A	30035	Fender brace for 18 inch wheels for BMW R26, R27 and R50-R69S chrome-plated	19,45 €	23,15 €
F210AB	320351	Fender brace for BMW R25/3 black	19,45 €	23,15 €
F210B	31035	Fender brace for 19 inch wheels chrome-plated	19,45 €	23,15 €
F210BA	310351	Fender brace for 19 inch wheels for BMW R25/2 and R51/2-R68 black	19,45 €	23,15 €
F210C	28038	Support Stand for mounting on Fender for BMW R51/2-R68 black	54,37 €	64,70 €
F210D	90108	Fender brace for BMW R25, R25/2 and R25/3, front, middle-brace crude	56,72 €	67,50 €
F210E	96261	Fender brace for BMW R68, front, middle-brace black painted (fits also for BMW R51/3-R67/3)	52,86 €	62,90 €
F211A	9008	Rubber plug for fender holes, rear, 7mm for 6mm holes	0,50 €	0,60 €
F211B	96154	Rubber plug for fender holes, rear, 8mm for 7mm holes	0,59 €	0,70 €
F211C	96260	Fender brace for BMW R68, rear chrome-plated	63,19 €	75,20 €
F212	96195	License plate support for BMW R25, R25/2 and R25/3, small, with beveled edges plastic-coated	15,25 €	18,15 €
F212	96178	License plate support for BMW R26, R27 and R50-R69S, big, black plastic-coated	12,06 €	14,35 €
F212B	0000965	License plate support for BMW R25-R25/3, R51/2 and R51/3, military-style, black	16,72 €	19,90 €
F221A	317025	Steering lock for BMW R25/3-R27, R50-R69S and R50/5-R100, short	9,92 €	11,80 €
F221B	1025	Steering lock for BMW R25, R25/2 and R51/2-R68, long	16,30 €	19,40 €
F221C	16009	Lock combination steering / toolbox for BMW R25/3 and R50-R69S	42,52 €	50,60 €
F222	2025	Steering lock cover for BMW R25/3-R27 and R50-R100/7	2,35 €	2,80 €
F222B	92025	Groove pin for steering-lock cover and stepshield for BMW R26, R27 and R50-R100/7	0,42 €	0,50 €
F223	32019	Spring washer for steering lock cover for BMW R25/3-R27 and R50-R100	0,25 €	0,30 €
F224	16104	Lock spring for steering lock	1,01 €	1,20 €
F300A	8003	Passenger seat grab handle Denfeld original	44,20 €	52,60 €
F300C	1058	Passenger seat grab handle Pagusa original	35,80 €	42,60 €
F300D	1057	Passenger seat grab handle Pagusa-like Reproduction	29,33 €	34,90 €
F301	0036015	Passenger seat to mount on the rack - BLITZ for BMW R25-R69S	137,81 €	163,99 €
F301A	35015	Passenger seat to mount on the rack - Pagusa for BMW R25-R69S	148,32 €	176,50 €
F301B	34015	Passenger seat to mount on the rack - Denfeld for BMW R25-R69S	191,43 €	227,80 €
F301C	97302	Passenger seat spring element for Pagusa seat top for BMW R25-R69S for mounting on fender	34,87 €	41,50 €
F302	0036017	Passenger seat to mount on the fender - BLITZ for BMW R25-R69S	135,29 €	161,00 €
F302A	35017	Passenger seat to mount on the fender - Denfeld for BMW R25-R69S	191,43 €	227,80 €
F302B	34017	Passenger seat to mount on the fender - Pagusa for BMW R25-R69S	147,02 €	174,95 €
F303	34115	Passenger seat spring set, (2 springs) for Pagusa for BMW R25-R69S with eye hook (open loop)	31,05 €	36,95 €
F303	3411500	Passenger seat spring set, (2 springs) for Pagusa and Denfeld for BMW R25-R69S closed loop	30,42 €	36,20 €
F304	9058	Seat top WITHOUT inner frame with front latch from Pagusa for BMW R25-R69S ONLY FOR passenger seat	49,54 €	58,95 €
F305	99013	Emblem "Uli's Motorradladen"	0,00 €	0,00 €
F305a	36625	Groove pin for emblem "Uli's Motorradladen"	0,00 €	0,00 €
F360	1052	Headlight guard for BMW R24-R75/5 chromed	16,72 €	19,90 €
F371	80165	Screw for tool box, square-end for BMW R24-R25/2, R26, R27 and R51/2-R68 single	2,77 €	3,30 €



F371	0180167	Screw Set for tool box, square-end for BMW R24-R25/2, R26, R27 and R51/2-R68 complete with mounting parts	3,74 €	4,45 €
F481	6003	Dual seat cover for BMW R24-R69S, slim NOT for US-version	45,80 €	54,50 €
F481	0006003	Dual seat cover for BMW R24-R69S, wide, US-version	45,80 €	54,50 €
F484	34676	Trim strip Set dual seat for BMW R26-R69S including screws and nuts	27,65 €	32,90 €
F485	922016	Nut for trim strip screw, dual seat	0,13 €	0,15 €
F486	31319	Trim strip screw for dual seat	1,18 €	1,40 €
F487	31015	Washer for trim strip screw dual seat for BMW R50/5-R100/7	0,38 €	0,45 €
F488	33552	Seat emblem "Schorsch Meier"	8,82 €	10,50 €
F490	02030	Passenger seat for BMW R68 and R69, leather swinger-type, WITHOUT seat holder/mounting parts	302,52 €	360,00 €
F490b	02032	Mounting kit for seat "Schorsch Meier" for BMW R24-R69S for mounting on fender	12,56 €	14,95 €
F491	96032	Mounting kit for swinger seat for BMW R68, rear black coated	71,43 €	85,00 €
F492	96031	Mounting kit for swinger seat for BMW R68 and R69, front stainless steel, black coated	30,25 €	36,00 €
F493	96033	Mounting kit for swinger seat for BMW R69, rear black coated	86,89 €	103,40 €
F590B	99007	Cap nut M 8 stainless steel	1,60 €	1,90 €
F590C	96122	Nut for rear fender brace for BMW R26-R69S and R51/3-R68 and upper engine mount	2,48 €	2,95 €



Group J: Frame, fender, tank, seat for all models 1955-1969

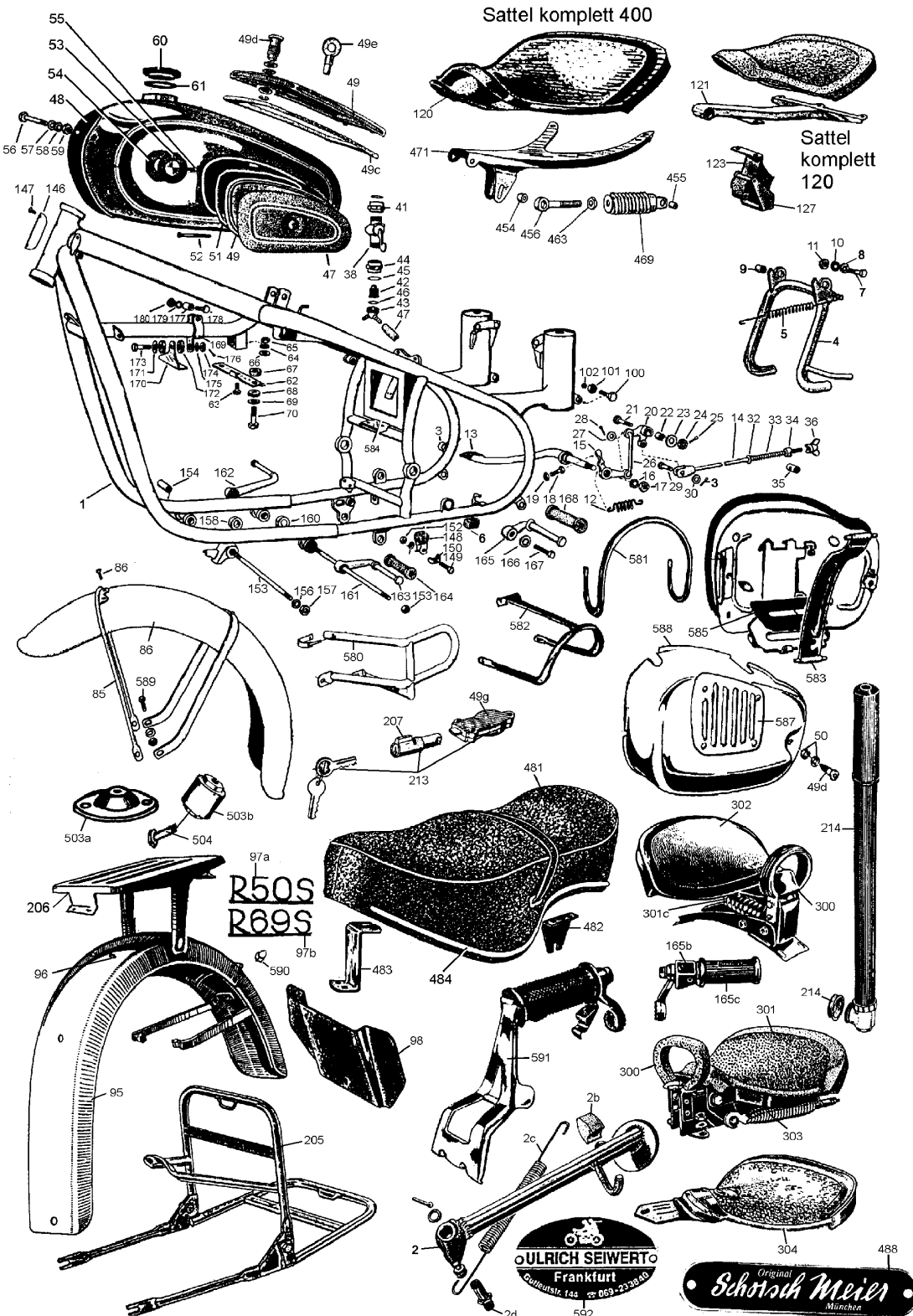

<u>Picture-No.</u>	<u>Article-No.</u>	<u>Description</u>	<u>Net</u>	<u>Gross</u>
J00	1303017	Fuel hose quick-connector, Ø 7,5mm	7,52 €	8,95 €
J00	1403017	Fuel hose quick-connector, Ø 9mm NOT for BMW-oldtimer-motorcycle	7,52 €	8,95 €
J000	4634260	Foot rest driver for BMW R51/2-R68 and R50-R69S, right side, long	25,13 €	29,90 €
J000	1237758	Leather bag carrier set for BMW R50-R69S, black for leather bag "Nostalgie" & "Classic"	83,95 €	99,90 €
J000	1238511	Leather bag Classic for BMW R25/3-R69S and R50/5-R75/5 with frame, black	193,19 €	229,90 €
J000	03017	Fuel hose tube	0,42 €	0,50 €
J000	4634125	Foot rest driver for BMW R51/2-R68 and R50-R69S, left side, short	25,13 €	29,90 €
J000	962601	Fender brace for BMW R50-R69S, rear sportstyle	65,97 €	78,50 €
j000	4084110	Gasket ring fuel cock Everbest-shape for BMW R25/3-R27 and R50/5-R75/5 fits also fuelcock for R24 with external thread	0,59 €	0,70 €
J000	80007	Lock ring pet cock for BMW R25-R69S	0,21 €	0,25 €
J000	99521	Leather bag, military/police style natural-coloured	167,98 €	199,90 €



J000	02181	Frame for Denfeld and Pagusa seat cover	28,36 €	33,75 €
J000	00986	Bracket (repair part) for center stand for BMW R50-R69S, right side to weld-in	58,74 €	69,90 €
J000	00987	Bracket (repair part) for center stand for BMW R50-R69S, left side to weld-in	62,52 €	74,40 €
J000	9988777	Leather bag, military/police style black, REMNANTS!	117,56 €	139,90 €
J000	9988666	Leather bag universal, 3-point universal-mounting black, REMNANTS!	117,56 €	139,90 €
J000	9952102	Leather bag, military/police style black, waterproof sealed	151,18 €	179,90 €
J000	0003683	Leather bag carrier set for BMW R26 and R27, black for leather bag "Nostalgie" & "Classic"	92,35 €	109,90 €
J000	0003920	Leather bag fixing screw (knurled-head screw) for leather bag "Nostalgie" & "Classic"	6,68 €	7,95 €
J000	0003855	Leather bag carrier set for BMW R51/3-R68, black for leather bag "Nostalgie" & "Classic"	83,95 €	99,90 €
J000	0003849	Leather bag carrier set for BMW R25/3, black for leather bag "Nostalgie" & "Classic"	100,76 €	119,90 €
J002	9024174	Spring side stand for BMW R27 stainless steel	5,00 €	5,95 €
J002A	24013	Side stand for BMW R50-R69S WITHOUT mounting parts	67,14 €	79,90 €
J002A	0024013	Spring shackle for side stand for BMW R50-R69S in conjunction with spring articlenr: 28216, self folding	9,66 €	11,50 €
J002B	24170	Side stand stop for BMW R50-R69S	3,32 €	3,95 €
J002c	0021119	Lock washer side stand for BMW R50-R69S	0,55 €	0,65 €
J002D	24173	Spring side stand for BMW R50-R69S zinced	4,12 €	4,90 €
J002D	24174	Spring side stand for BMW R50-R69S stainless steel	6,64 €	7,90 €
J002E	30002	Bolt side stand for BMW R50-R69S, M12	14,33 €	17,05 €
J002F	30001	Bolt side stand for BMW R50-R69S, M14	13,19 €	15,70 €
J002F	1230001	Bolt side stand for BMW R50-R69S, thread: M14, with washer and splint for automatic flip-up version (more parts needed, see product details)	16,72 €	19,90 €
J002J	24045	Side stand for BMW R27 complete, pre-installed, stainless steel	109,20 €	129,95 €
J003	99900	Weld-on ball for sidecar mount, for 1 Zylinder-frame	23,95 €	28,50 €
J003	99901	Weld-on ball for sidecar mount R51/2-R69S	16,38 €	19,49 €
J003B	14047	Ballpin for BMW R25 for sidecar connection, screw-in frame lower bottom	15,04 €	17,90 €
J004A	2080	Center stand for BMW R50-R69S	99,16 €	118,00 €
J004B	3080	Center stand for BMW R26 and R27	99,16 €	118,00 €
J005A	28218	Spring center stand for BMW R50-R69S	2,94 €	3,50 €
J005B	28118	Spring center stand for BMW R25/3-R27 and R25/2 middle mounting	2,98 €	3,55 €
J006	28135	Center stand stopper for BMW R25-R69S and swing arm bumper and kickstarter stopper for BMW R27	2,35 €	2,80 €
J007	12620	Screw M10 x 30, hexagon	0,67 €	0,80 €
J007	14665	Screw for center stand for BMW R25-R27, M12 x 80	1,47 €	1,75 €
J008	98458	Spring washer B12, DIN137B	0,28 €	0,33 €
J009A	28130	Center stand bushing for BMW R25-R27 hardened	4,24 €	5,05 €
J009B	28230	Bushing center stand for BMW R50-R69S hardened	4,24 €	5,05 €
J010	98424	Washer M13, DIN125 zinced	0,17 €	0,20 €
J011	98375	Nut M12 x 1,5 zinced	0,67 €	0,80 €
J012A	44127	Spring for foot brake pedal for BMW R26 and R27	8,32 €	9,90 €
J012B	44215	Spring for foot brake pedal for BMW R50-R69S	2,69 €	3,20 €
J013A	44151	Foot brake pedal for BMW R25-R27 used	25,13 €	29,90 €
J013AA	4044009	Bolt for foot brake pedal for BMW R25, R25/2 and R25/3	26,05 €	31,00 €
J013B	44033	Bolt for foot brake pedal for BMW R50-R69S	36,05 €	42,90 €
J013C	44031	Foot brake pedal for BMW R50-R69S	90,59 €	107,80 €
J013D	44032	Foot brake pedal for BMW R50-R69S used	62,94 €	74,90 €
J014a	44229	Brake rod for BMW R50-R69S WITHOUT attachment parts (naked) stainless steel	19,66 €	23,40 €
J014B	44225	Brake rod for BMW R50-R69S complete with 8mm bolt, stainless steel	41,60 €	49,50 €
J014D	44159	Brake rod for BMW R 26 and R27 complete stainless steel	41,60 €	49,50 €
J015	44234	Brake rod direction change for BMW R50-R69S	34,41 €	40,95 €
J018	98155	Screw for clutch 1-cylinder, also oilpump cover for BMW R60/6-R90S, M 6 x 16, hexagon	0,13 €	0,15 €
J020	044226	Brake angle lever for BMW R50-R69S	20,97 €	24,95 €
J021	098207	Screw M 8 x 45, hexagon with shaft stainless steel	0,46 €	0,55 €
J021	98207	Screw M 8 x 45, hexagon with shaft	0,25 €	0,30 €
J022	044266	Bushing brake-angle for BMW R50-R69S	3,78 €	4,50 €
J024	23421	Castle nut M 8 zinced	0,97 €	1,15 €
J026	44262	Brake push rod for BMW R50-R69S	11,18 €	13,30 €
J029A	40395	Brake rod bolt for BMW R26-R27 and R50-R69S, 8mm stainless steel polished	4,35 €	5,18 €
J029B	34961	Brake rod bolt with lock spring, 6x12mm	2,44 €	2,90 €
J030A	45090	Brake rod head, round for 8mm bolts stainless steel	9,71 €	11,55 €
J030B	44137	Brake rod head, square-shape for 6mm bolt stainless steel polished	14,83 €	17,65 €
J031	36226	Split pin 2,0 x 32	0,13 €	0,15 €
J031a	44136	Split pin for brake rod stainless steel	0,13 €	0,15 €
J033	44138	Brake rod spring stainless steel polished	3,49 €	4,15 €
J034	44133	Brake rod ring, vaulted stainless steel polished	3,83 €	4,56 €



J035	44230	Brake rod bolt, 14mm stainless steel polished	3,07 €	3,65 €
J036a	4044115	Wing nut for brake rod for BMW R25-R69S stainless steel chromed	10,84 €	12,90 €
J037	3017	Fuel hose, oldtime-look, per meter	4,08 €	4,86 €
J037	3017713	Fuel hose, rubber-look, per meter	5,46 €	6,50 €
J038	4084030	Pet cock for R51/3-R69S, with 2 outflow/leaving, "Everbest" ORIGINAL-FORM "EVERBEST"	44,12 €	52,50 €
J038	84031	Pet cock for BMW R51/3-R69S, with 2 outflow/leaving with drain-pool	36,89 €	43,90 €
J038	08008	Pet cock for BMW R25/3-R27 and R50/5-R100 WITH drain-pool	36,89 €	43,90 €
J038	84030	Pet cock for BMW R51/3-R69S, with 2 outflow/leaving	32,69 €	38,90 €
J038	80008	Pet cock for BMW R25/3-R27 and R50/5-R75/5, with 1 outflow/leaving	28,53 €	33,95 €
J039	40512	Pet cock gasket (Kork) for Kakoma-petcock	2,69 €	3,20 €
J041	84120	Pet cock nut for R25/3-R69S M16x1 left-hand thread , M20x1 right-hand thread	2,77 €	3,30 €
J041A	40060	Gasket ring fuel cock/tank for BMW R25/3-R69S and R50/5-R100 for all fuel cocks with connection M20x1	0,66 €	0,79 €
J042A	33368	Pet cock sieve in hose connector	2,10 €	2,50 €
J042B	99908	Pet cock sieve in tank for BMW R24-R69S Inner Ø: 9mm, outer Ø: 10,3mm, length: 60mm	2,27 €	2,70 €
J042C	80005	Pet cock spring for BMW R25-R69S	0,56 €	0,67 €
J043A	33366	Pet cock fuel line adaptor (single) with fine sieve, plastic	2,35 €	2,80 €
J043AA	99880	Pet cock fuel line adaptor (single) for "Frankfurter Modell"	7,23 €	8,60 €
J043B	84178	Pet cock fuel line adaptor (double) Karcoma REMNANTS	5,80 €	6,90 €
J043B1	9984178	Gasket ring fuel cock tap hose connection 2-fold Karcoma	0,25 €	0,30 €
J043BA	99881	Pet cock fuel line adaptor (double) for "Frankfurter Modell"	7,52 €	8,95 €
J044A	84169	Pet cock nut, left/right threat buttom for double outlet	1,51 €	1,80 €
J044B	33369	Pet cock coupling nut, buttom for hose connector with 1 outlet	1,01 €	1,20 €
J047	6009	Knee pad for "Hoske"-tank, left and right (article is 1 pair = 2 pc.)	50,34 €	59,90 €
J047A	80187	Knee pad for BMW R50-R69S, only right side (single = 1 pc.)	18,07 €	21,50 €
J047B	4080183	Knee pad for BMW R26 and R27, right and left side (article is 1 pair = 2 pc.)	32,06 €	38,15 €
J047C	80183	Knee pad for BMW R26 and R27, only left side (single = 1 pc.)	17,23 €	20,50 €
J047D	4080189	Knee pad for BMW R50-R69S, right and left side (article is 1 pair = 2 pc.)	32,77 €	39,00 €
J047E	1088	Knee pad for "Schorsch Meier"-tank, only left side (single = 1 pc.)	26,89 €	32,00 €
J047E	1088001	Knee pad for "Schorsch Meier"-tank, only right side (single = 1 pc.)	26,89 €	32,00 €
J047F	80189	Knee pad for BMW R50-R69S, only left side (with hole) (single = 1 pc.)	18,07 €	21,50 €
J047G	80141	Knee pad holder for BMW R26, R27 and R50-R69S, left side (weld on)	10,29 €	12,25 €
J047G	80140	Knee pad holder for BMW R26, R27 and R50-R69S, right side (weld on)	10,29 €	12,25 €
J047H	1088007	Knee pad holder for "Schorsch Meier"-tank, right side (weld-on)	20,97 €	24,95 €
J047H	1088008	Knee pad holder for "Schorsch Meier"-tank, left side (weld-on)	20,97 €	24,95 €
J048	0035286	Fuel tank for BMW R26 and R27, primed original BMW, NEW	1.529,41 €	1.820,00 €
J048	45241	Fuel tank for BMW R26 and R27, new painted and stripped (refurbished)	718,49 €	855,00 €
J048	0035287	Fuel tank for BMW R26 and R27, painted and stripped original BMW, NEW	1.134,45 €	1.350,00 €
J048C	59030	Fuel tank for BMW R50-R69S, new painted and stripped (refurbished)	714,29 €	850,00 €
J048E	49030	Fuel tank for BMW R51/3-R68, new painted and stripped, 24 liters, "Schorsch Meier" Replica	920,17 €	1.095,00 €
J048F	0035292	Fuel tank for BMW R50-R69S, primed, "Schorsch Meier" original BMW, NEW	924,37 €	1.100,00 €
J049	80288	Gasket tool box for BMW R25/3 and R50-R69S	2,48 €	2,95 €
J049	80270	Tool box cover for BMW R50-R69S new rebuild, black painted	54,54 €	64,90 €
J049	80165	Screw for tool box, square-end for BMW R24-R25/2, R26, R27 and R51/2-R68 single	2,77 €	3,30 €
J049	80188	Gasket tool box for BMW R24-R25/2, R26, R27 and R51/3-R68, tank above	5,00 €	5,95 €
J049	5076	Lock for tool box for BMW R25/3 and R50-R69S	29,16 €	34,70 €
J049	31298	Tool box cover for BMW R25/2, R26, R27, R51/3-R68, R65 and R50/5-R100 police model, opens lengthways	40,97 €	48,75 €
J049	41016	Key for tool box, square-end for BMW R24-R25/2, R26, R27 and R51/2-R68 also battery cover key for BMW R26 and R27	3,78 €	4,50 €
J049	0180167	Screw Set for tool box, square-end for BMW R24-R25/2, R26, R27 and R51/2-R68 complete with mounting parts	3,74 €	4,45 €
J049DA	0180165	Batterie cover screw, square for BMW R26 and R27 (separate)	2,77 €	3,30 €
J049DA	0180166	Batterie cover screw, square for BMW R26 and R27 (complete with mounting parts)	3,74 €	4,45 €
J050A	4034156	Kickstarter bumper mounting spacer for BMW R24-R69S	1,93 €	2,30 €
J050A	63073	Gasket ring toolbox screw, M10x14x1.5	0,21 €	0,25 €
J050B	63108	O-ring tool box lock screw for BMW R24, R25, R25/2, R26, R27 and R51/2-R68	0,34 €	0,40 €
J050C	07161	Lock ring for tool box screw for BMW R24-R25/2, R26, R27 and R51/2-R68	0,29 €	0,35 €
J052	47463	Bolt for tool box cover for BMW R25/3 and R50-R69S for tool compartment laterally	2,48 €	2,95 €
J052	4080176	Bolt for tool box cover for BMW R24-R25/2, R26, R27 und R51/2-R68 for tool compartment cover above, stainless steel	3,78 €	4,50 €
J053	0035269	Emblem for BMW R25/3-R27, R51/2-R68 and R50-R69S, "old letters", Tank original BMW	43,78 €	52,10 €
J053	0035322	Emblem for BMW R25/3, R26 and R27, "old letters", tank original BMW	43,78 €	52,10 €
J054A	12001	Emblem rubber for BMW R24-R69S	1,51 €	1,80 €



J054B	99012	Emblem collar for BMW R24-R69S for enamel emblem Ø=60mm, stainless steel	14,20 €	16,90 €
J055	1038	Emblem screw for BMW R25/2-R69S stainless steel	0,34 €	0,40 €
J055a	9910381	Emblem screw for BMW R24-R69S, cross-slot stainless steel	0,38 €	0,45 €
J056	98210	Screw M 8 x 110, hexagon with shaft e.g. as Fuel tank holder screw, front for BMW R26 and R27	0,97 €	1,15 €
J056	14093	Fuel tank holder screw M 8 x 1 x 100 for BMW R50-R69S, front	1,47 €	1,75 €
J056C	80136	Distance sleeve for tank for BMW R26 and R27, front	3,70 €	4,40 €
J057	80137	Fuel tank holder rubber for BMW R25/3, R26 and R27, front, conical	1,85 €	2,20 €
J060A	1053	Fuel tank cap for BMW R24-R69S, lockable, with lock cover with rubber gasket, stainless steel polished	14,33 €	17,05 €
J060B	80126	Fuel tank cap for BMW R24-R69S, NOT lockable with rubber gasket, aluminum	12,23 €	14,55 €
J060C	1180126	Fuel tank cap for BMW R24-R69S, NOT lockable with rubber gasket, chromed	12,23 €	14,55 €
J060C	1001053	Fuel tank cap for BMW R24-R69S, lockable, WITHOUT lock cover with rubber gasket, stainless steel polished	14,24 €	16,95 €
J061	3053	Gasket for fuel tank cap from BMW R24-R69S	1,51 €	1,80 €
J062	80194	Fuel tank bracket for BMW R26 and R50-R69S	9,16 €	10,90 €
J067	3008	Fuel tank holder rubber for BMW R25/2-R69S, rear	1,26 €	1,50 €
J070	14050	Fuel tank holder screw M 8 x 1 x 30, hexagon, for BMW R25/2-R69S, rear also for seat spring	0,59 €	0,70 €
J084A	0035303	Fender for BMW R26 and R27, front (Mudguard) ground coat, original BMW new part	300,50 €	357,60 €
J085	30035	Fender brace for 18 inch wheels for BMW R26, R27 and R50-R69S chrome-plated	19,45 €	23,15 €
J085	5090150	Fender brace for BMW R50-R69S, front, middle/top only for "US-Version", chrome-plated	112,77 €	134,20 €
J085	5090151	Fender brace for BMW R50-R69S, front, bottom only for "US-Version", chrome-plated	43,11 €	51,30 €
J085B	0035304	Fender for BMW R26 and R27, front (Mudguard) painted, original BMW new part	515,04 €	612,90 €
J085C	90022	Fender for BMW R50-R69S, front (Mudguard) (R68-shape) narrow, painted and lined, with middle brace	306,72 €	365,00 €
J086	13222	Screw for fender brace for BMW R25-R69S stainless steel polished	2,23 €	2,65 €
J086b	90040	Fender for BMW R26-R69S, front (Mudguard) ground coating, without middle brace, replica, "coating has to be removed" !	147,06 €	175,00 €
J086c	0013220	Fender for BMW R26, R27 and R50-R69S, front (Mudguard) new painted and lined, with middle brace, replica	327,65 €	389,90 €
J086d	0035307	Fender for BMW R50-69S, front (Mudguard) ground coat, with middle brace, original BMW new part	343,53 €	408,80 €
J086d	0013221	Fender for BMW R26, R27 and R50-R69S, front (Mudguard) new painted and lined, without middle brace, replica	327,65 €	389,90 €
J086e	3296261	Fender brace for BMW R26, R27 and R50-R69S, front, middle-brace crude	29,33 €	34,90 €
J095a	22011	Fender for BMW R50-R69S, rear ground coat, original BMW new part	794,12 €	945,00 €
J095A	21001	Fender for BMW R26 and R27, rear painted and lined, replica	747,90 €	890,00 €
J095b	23001	Fender for BMW R50-R69S, rear ground coat, replica	419,33 €	499,00 €
J095b	021001	Fender for BMW R26 and R27, rear crude, replica	419,33 €	499,00 €
J095C	35295	Fender for BMW R26 and R27, rear ground coat, original BMW new part	872,69 €	1.038,50 €
J095D	35296	Fender for BMW R26 and R27, rear painted and lined, original BMW new part	1.050,42 €	1.250,00 €
J095E	9614906	Fender badge "R27" chromed	25,63 €	30,50 €
J096A	9008	Rubber plug for fender holes, rear, 7mm for 6mm holes	0,50 €	0,60 €
J096B	96154	Rubber plug for fender holes, rear, 8mm for 7mm holes	0,59 €	0,70 €
J096B	5096118	Hinge pin for rear fender of BMW R25-R69S, stainless steel	2,14 €	2,55 €
J097	96148	Fender badge "R50S" chromed	30,59 €	36,40 €
J097B	96147	Fender badge "R69S" chromed	30,59 €	36,40 €
J097C	98470	Clamp ring, clip-on, 4mm	0,25 €	0,30 €
J097D	9614903	Fender badge "R50" chromed	25,63 €	30,50 €
J097D	9614904	Fender badge "R50/2" chrome	25,63 €	30,50 €
J097D	9614905	Fender badge "R60/2" chromed	25,63 €	30,50 €
J098	96195	License plate support for BMW R25, R25/2 and R25/3, small, with beveled edges plastic-coated	15,25 €	18,15 €
J098	96178	License plate support for BMW R26, R27 and R50-R69S, big, black plastic-coated	12,06 €	14,35 €
J098B	0000965	License plate support for BMW R25-R25/3, R51/2 and R51/3, military-style, black	16,72 €	19,90 €
J100	98203	Screw M 8 x 30, hexagon	0,25 €	0,30 €
J101	96152	Cap nut M 8 for rear fender chromed	2,73 €	3,25 €
J120	9906042	Seat top WITHOUT inner frame from BLITZ for BMW R25-R69S for driver and passenger seat	41,18 €	49,00 €
J120	9996042	Seat top WITH inner frame from BLITZ for BMW R25-R69S for driver and passenger seat	74,71 €	88,90 €
J120	0214142	Driver's seat for BMW R50-R69S complete BLITZ	155,00 €	184,45 €
J120	1009066	Seat cover leatherette for solo and passenger saddle, for BMW R25-R69S, black with white welting	40,34 €	48,00 €
J120A	0002141	Driver's seat for BMW R50-R69S complete Pagusa	171,39 €	203,95 €
J120AA	02140	Driver's seat for BMW R50-R69S complete Denfeld	195,04 €	232,10 €
J120B	02011	Seat top WITH inner frame from Denfeld for BMW R25-R69S, black for driver and passenger seat	102,27 €	121,70 €



J120C	02012	Seat top WITH inner frame from Pagusa for BMW R25-R69S for driver and passenger seat	80,59 €	95,90 €
J120D	1003	Seat top WITHOUT inner frame from Denfeld for BMW R25-R69S, black for driver and passenger seat	68,32 €	81,30 €
J120DA	91003	Seat top WITHOUT inner frame from Denfeld for BMW R25-R69S, white for driver and passenger seat	84,45 €	100,50 €
J120E	10030	Seat top WITHOUT inner frame from Pagusa for BMW R25-R69S for driver and passenger seat	46,18 €	54,95 €
J121A	12166	Seat carrier driver seat for BMW R50-R69S	70,59 €	84,00 €
J121A	36205	Holding angle for seat for BMW R25-R68 2 holes mounting	5,55 €	6,60 €
J121B	92141	Silent block seat carrier for BMW R50 and R51/3-R68 from year of manufacture 1954 and seat adapter for BMW R25/3-R27	9,20 €	10,95 €
J121B	99102	Holding angle for seat for BMW BMW R50-R69S "Z-shape" angle support with stud bolt	5,52 €	6,57 €
J122	14364	Screw M10 x 1 x 70, hexagon with shaft	1,26 €	1,50 €
J123	10003	Silent block for drivers seat for BMW R50-R69S	43,40 €	51,65 €
J124	98157	Screw M 6 x 20, hexagon	0,13 €	0,15 €
J127	02190	Silent block holder for driver seat for BMW R50-R69S	12,77 €	15,20 €
J146	2037	Identification plate BMW "neutral" for BMW R25-R69S	3,36 €	4,00 €
J146	4034138	Identification plate for BMW R26	11,68 €	13,90 €
J146	4034142	Identification plate for BMW R27	11,68 €	13,90 €
J146	4034246	Identification plate for BMW R50 also for BMW R50/2	11,68 €	13,90 €
J146	4034249	Identification plate for BMW R60	11,68 €	13,90 €
J146	4034206	Identification plate for BMW R60/2	11,68 €	13,90 €
J146	4034247	Identification plate for BMW R69	11,68 €	13,90 €
J146	4034204	Identification plate for BMW R69S	11,68 €	13,90 €
J147	9916604	Screw for identification plate, round head for BMW R24-R69S stainless steel	2,94 €	3,50 €
J148	28135	Center stand stopper for BMW R25-R69S and swing arm bumper and kickstarter stopper for BMW R27	2,35 €	2,80 €
J148B	26016	Kick starter bumper for BMW R51/2-R69S	8,19 €	9,75 €
J148D	25116	Kick starter bumper for BMW R24-R26	7,35 €	8,75 €
J150	34156	Kick starter bumper mounting set for BMW R24-R69S	4,16 €	4,95 €
J153A	34216	Engine axle for BMW R51/3-R69S, front stainless steel	10,04 €	11,95 €
J153B	39032	Engine axle for BMW R25/3 and R26, upper	14,20 €	16,90 €
J154	34224	Bushing engine mounting axle for BMW R51/3-R69S	3,57 €	4,25 €
J156	98425	Washer M13, DIN125/A2 stainless steel	0,42 €	0,50 €
J157A	98375	Nut M12 x 1,5 zincked	0,67 €	0,80 €
J157B	98377	Nut M12 x 1,5, flat stainless steel	2,10 €	2,50 €
J157B	98378	Nut M12 x 1,5 stainless steel	2,44 €	2,90 €
J160a	34227	Distance ring engine for BMW R51/3-R69S and handle bar for BMW R27	3,28 €	3,90 €
J161A	34210	Engine axle for BMW R51/3-R69S, rear	9,20 €	10,95 €
J161B	34113	Engine axle for BMW R25, R25/2, R25/3 and R26, lower	9,96 €	11,85 €
J162a	4034260	Foot rest for BMW R50-R69S and R50/5-R100, right side	25,13 €	29,90 €
J162b	34151	Foot rest driver for BMW R51/3-R69S used - Please indicate whether left or right side !!!	12,78 €	15,21 €
J163	9034125	Foot rest driver for BMW R50-69S and R50/5-R100, left side	25,13 €	29,90 €
J164	34107	Footrest rubber for BMW R25-R90/6, round/stiff	5,00 €	5,95 €
J165A	34153	Foot rest driver for BMW R25-R27 and for passenger for BMW R25-R27, R50-R69S stiff	15,13 €	18,00 €
J165B	34150	Foot rest passenger for BMW R25-R27 and R50-R69S, flip-up, oval-shape	23,53 €	28,00 €
J165BA	0034261	Foot rest holder for BMW R24-R27 and R50-R69S, cropped, 10,3mm-Hole for flip-ups, rough teethed	6,64 €	7,90 €
J165BB	0034262	Foot rest holder for BMW R24-R27, for Akipp stand mount short, rough teethed, crooped, 12,5mm-Hole	6,64 €	7,90 €
J165BC	1034262	Foot rest holder for BMW BMW R51/2-R69S, for Akipp stand mounting long, finely tooth, 12,5mm-Hole	6,64 €	7,90 €
J165C	10007	Footrest rubber for BMW R25-R27 and R50-R69S, oval shape	5,00 €	5,95 €
J167	98257	Screw M12 x 30, hexagon	0,80 €	0,95 €
J169	34278	Engine mounting clamp for BMW R51/3-R69S	16,72 €	19,90 €
J170a	34282	Engine mounting angle bracket for BMW R50-R69S, upper	11,26 €	13,40 €
J170b	34270	Engine mounting angle bracket for BMW R51/3-R68, upper	14,83 €	17,65 €
J171	9998416	Large diameter washer, 8 x 30mm, thin	0,13 €	0,15 €
J171a	80148	Engine mounting rubber for BMW R51/3-R69S	1,93 €	2,30 €
J172	80148	Engine mounting rubber for BMW R51/3-R69S	1,93 €	2,30 €
J173	98205	Screw M 8 x 35, hexagon with shaft e.g. for carburettor flansch for BMW R26/R27	0,25 €	0,30 €
J173	98216	Screw M 8 x 1 x 40, hexagon with shaft	0,84 €	1,00 €
J174	98414	Washer M 8, DIN125, Form A cinced	0,06 €	0,07 €
J175	98351	Nut M 8 x 1, self-locking (lock nut) zincked	0,42 €	0,50 €
J177	34274	Distance sleeve for motor mounting for BMW R51/3-R69S	3,53 €	4,20 €
J178	98205	Screw M 8 x 35, hexagon with shaft e.g. for carburettor flansch for BMW R26/R27	0,25 €	0,30 €
J200	99993	Fuel-filter with paper inlay, stick-in-hose, universal, transparent	2,35 €	2,80 €



J205	96216	Luggage rack for BMW R24-R69S, original shape, foldaway chromed	83,11 €	98,90 €
J205A	92239	Rack rubber strap Denfeld, 37cm for BMW R24-R69S	9,24 €	11,00 €
J205A	0962161	Rubber for luggage rack for BMW R24-R69S foldaway, black	5,17 €	6,15 €
J205B	92244	Rack rubber strap Denfeld, 45cm for BMW R24-R69S	10,50 €	12,50 €
J205B	0962162	Rubber for luggage rack for BMW R24-R69S foldaway, red	5,17 €	6,15 €
J205C	92255	Rack rubber strap Denfeld, 54cm for BMW R24-R69S	12,10 €	14,40 €
J206A	96200	Luggage grid for BMW R26 and R27	77,52 €	92,25 €
J206B	96214	Luggage grid for BMW R50-R69S	79,75 €	94,90 €
J207	317025	Steering lock for BMW R25/3-R27, R50-R69S and R50/5-R100, short	9,92 €	11,80 €
J208	2025	Steering lock cover for BMW R25/3-R27 and R50-R100/7	2,35 €	2,80 €
J208B	92025	Groove pin for steering-lock cover and stepshield for BMW R26, R27 and R50-R100/7	0,42 €	0,50 €
J210	16104	Lock spring for steering lock	1,01 €	1,20 €
J211	32019	Spring washer for steering lock cover for BMW R25/3-R27 and R50-R100	0,25 €	0,30 €
J213	16009	Lock combination steering / toolbox for BMW R25/3 and R50-R69S	42,52 €	50,60 €
J214	1050	Tire air pump for BMW R25-R69S, black	15,42 €	18,35 €
J214	10501	Tire air pump for BMW R25-R69S, silver	15,42 €	18,35 €
J214B	90172	Dust cap for tire air pump	0,50 €	0,60 €
J214D	90176	Rubber gasket for tire air pump	1,09 €	1,30 €
J214E	90170	Tire air pump valve breather	0,67 €	0,80 €
J214F	90174	Rubber back-pressure valve for tire air pump	0,42 €	0,50 €
J214F	0010502	Tire air pump for BMW R25-R69S, chromed	21,43 €	25,50 €
J300A	8003	Passenger seat grab handle Denfeld original	44,20 €	52,60 €
J300C	1058	Passenger seat grab handle Pagusa original	35,80 €	42,60 €
J300D	1057	Passenger seat grab handle Pagusa-like Reproduction	29,33 €	34,90 €
J301	0036015	Passenger seat to mount on the rack - BLITZ for BMW R25-R69S	137,81 €	163,99 €
J301A	35015	Passenger seat to mount on the rack - Pagusa for BMW R25-R69S	148,32 €	176,50 €
J301B	34015	Passenger seat to mount on the rack - Denfeld for BMW R25-R69S	191,43 €	227,80 €
J301C	97302	Passenger seat spring element for Pagusa seat top for BMW R25-R69S for mounting on fender	34,87 €	41,50 €
J302	0036017	Passenger seat to mount on the fender - BLITZ for BMW R25-R69S	135,29 €	161,00 €
J302A	35017	Passenger seat to mount on the fender - Denfeld for BMW R25-R69S	191,43 €	227,80 €
J302B	34017	Passenger seat to mount on the fender - Pagusa for BMW R25-R69S	147,02 €	174,95 €
J303	34115	Passenger seat spring set, (2 springs) for Pagusa for BMW R25-R69S with eye hook (open loop)	31,05 €	36,95 €
J303	3411500	Passenger seat spring set, (2 springs) for Pagusa and Denfeld for BMW R25-R69S closed loop	30,42 €	36,20 €
J304	9058	Seat top WITHOUT inner frame with front latch from Pagusa for BMW R25-R69S ONLY FOR passenger seat	49,54 €	58,95 €
J400	0200942	Driver's seat for BMW R25/2-R68, R26 and R27 complete BLITZ	142,86 €	170,00 €
J400A	02009	Driver's seat for BMW R25/2-R68, R26 and R27 complete Pagusa	157,90 €	187,90 €
J400B	02179	Driver's seat for BMW R25/2-R68, R26 and R27 complete Denfeld	187,06 €	222,60 €
J469A	021020	Seat spring driver seat for BMW R25/2-R68 chrome-plated	15,21 €	18,10 €
J469B	02102	Seat spring for BMW R25/2-R27 and R51/2-R68 chrome-plated	53,36 €	63,50 €
J471B	02116	Seat carrier driver seat for BMW R25/2-R68	53,70 €	63,90 €
J480A	34022	Dual seat for BMW R25-R69S original Denfeld	363,36 €	432,40 €
J480B	34021	Dual seat for BMW R25-R69S Reproduction	197,44 €	234,95 €
J480C	34028	Dual seat for BMW R50-R69S, USA wide version, original Denfeld	384,54 €	457,60 €
J481	6003	Dual seat cover for BMW R24-R69S, slim NOT for US-version	45,80 €	54,50 €
J481	0006003	Dual seat cover for BMW R24-R69S, wide, US-version	45,80 €	54,50 €
J481C	02007	Seat pad sport "Denfeld" for BMW R24-R69S, rear	289,41 €	344,40 €
J481D	0200701	Mounting kit for seat "Denfeld" for BMW R24-R69S for mounting on fender	19,41 €	23,10 €
J481D	7002007	Seat pad sport for BMW R24-R69S, "Denfeld-form" only for mounting DIRECTLY on fender	125,97 €	149,90 €
J481E	0200702	Mounting kit for seat "Denfeld" for BMW R24-R69S for mounting on luggage rack	19,24 €	22,90 €
J481E	7002008	Seat pad sport for BMW R24-R69S, "Denfeld-form" ONLY for mounting on luggage rack	130,00 €	154,70 €
J482	13463	Dual seat holder bracket for BMW R50-R69S, rear lateral ear	8,19 €	9,75 €
J482	9034116	Dual seat holder bracket for BMW R26 and R27, rear lateral ear	8,19 €	9,75 €
J483	13457	Dual seat holder bracket for BMW R50-R69S, front, Z-shape	10,00 €	11,90 €
J483A	9034117	Dual seat holder bracket for BMW R24-R68, front	10,00 €	11,90 €
J484	31319	Trim strip screw for dual seat	1,18 €	1,40 €
J484	34676	Trim strip Set dual seat for BMW R26-R69S including screws and nuts	27,65 €	32,90 €
J484	922016	Nut for trim strip screw, dual seat	0,13 €	0,15 €
J484	31015	Washer for trim strip screw dual seat for BMW R50/5-R100/7	0,38 €	0,45 €
J488	33552	Seat emblem "Schorsch Meier"	8,82 €	10,50 €
J500B	32032	Air filter housing for BMW R26 and R27 used	109,16 €	129,90 €
J500BB	32031	Air filter housing for BMW R26 and R27 used, new coated, black	50,00 €	59,50 €
J501	34166	Engine mounting rubber for BMW R25/3 and R26, upper	2,48 €	2,95 €



J502	34119	Engine mounting rubber for BMW R25/3 and R26, lower	3,32 €	3,95 €
J503A	34130	Engine mounting rubber for BMW R27, upper	11,26 €	13,40 €
J503B	34131	Engine mounting rubber for BMW R27, lower	11,26 €	13,40 €
J504	98240	Screw M10 x 1 x 20, hexagon	0,80 €	0,95 €
J505	034126	Engine mounting angle bracket for BMW R27, upper	8,57 €	10,20 €
J560	42168	Rubber buffer for battery carrier for BMW R26 and R27	2,48 €	2,95 €
J580	2052	Crash bar set for BMW R50-R69S, Fehling, chrome 2 parts, with mounting-material	148,70 €	176,95 €
J580A	24156	Crash bar for BMW R50-R69S, trapeze shape, chrome WITHOUT mounting parts, (in connection with article 09024171)	151,18 €	179,90 €
J580AA	09024171	Crash bar mounting kit for BMW R50-R69S trapeze-shape	25,13 €	29,90 €
J581	1052	Headlight guard for BMW R24-R75/5 chromed	16,72 €	19,90 €
J582A	9910521	Taillight guard for BMW R26, R27 and R50-R69S from year of manufacture 09/1958 stainless steel	29,33 €	34,90 €
J583	30016	Battery strap for BMW R24-R25/3, R50-R69S rubber 250mm	4,87 €	5,80 €
J583	31016	Battery strap for BMW R26 and R27 rubber 190mm	4,87 €	5,80 €
J584	42212	Battery carrier for BMW R50-R69S, 6 Volt	18,49 €	22,00 €
J584A	42213	Battery carrier for BMW R50-R69S, 6V16Ah, US-Version also suitable for 12V batteries	18,49 €	22,00 €
J585B	042111	Battery support (foam rubber) for 6V12Ah Battery for BMW R26 and R27 110x50mm	2,98 €	3,55 €
J586	42170	Gasket for battery cover for BMW R26 and R27	3,19 €	3,80 €
J587	42160	Battery cover protection plate for BMW R26 and R27	19,92 €	23,70 €
J588	42162	Battery cover for R26 and R27 with alu step-protector black	86,47 €	102,90 €
J588B	080140	Rubber washer battery cover rubber washer for BMW R26 and R27 also for tool-box	1,43 €	1,70 €
J589	98201	Screw for chain tensioner, simplex for BMW R45/R65 and R60/7-R100, M 8 x 20, hexagon and holding screw for exhaust pipe for BMW R50-R69S	0,17 €	0,20 €
J590B	99007	Cap nut M 8 stainless steel	1,60 €	1,90 €
J590C	96122	Nut for rear fender brace for BMW R26-R69S and R51/3-R68 and upper engine mount	2,48 €	2,95 €
J591	90240	Side stand fit to footrest for BMW R51/2-R69S "Akip", with all parts	79,79 €	94,95 €
J591A	9024001	Side stand fit to footrest for BMW R25-R27 "Akip", with all parts	79,79 €	94,95 €
J592	99013	Emblem "Uli's Motorradladen"	0,00 €	0,00 €
J592a	36625	Groove pin for emblem "Uli's Motorradladen"	0,00 €	0,00 €
J593	42179	Battery supporting rubber inside cover for BMW R26 and R27	2,77 €	3,30 €



Group A: Exhaust system all models 1948-1969

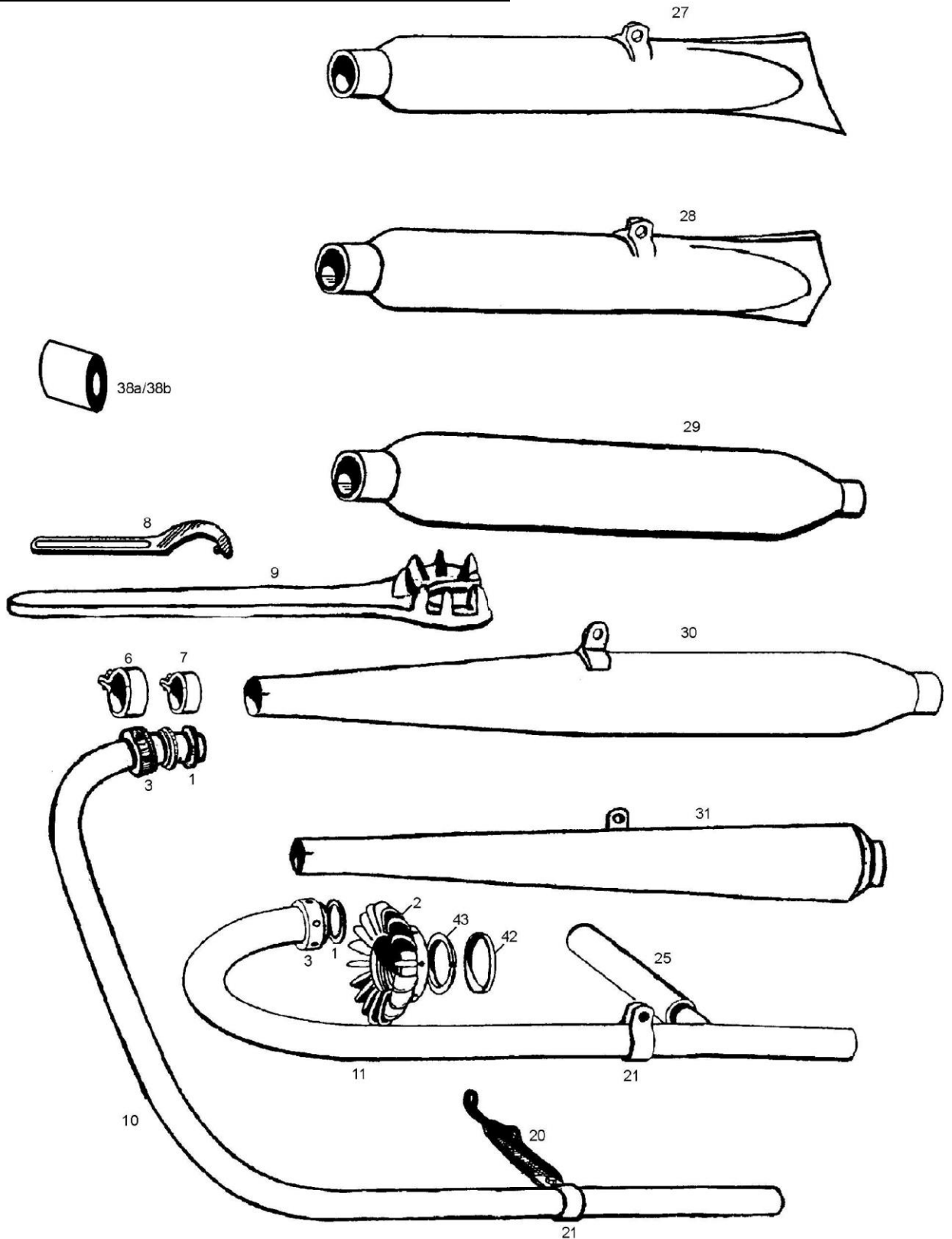

<u>Picture-No.</u>	<u>Article-No.</u>	<u>Description</u>	<u>Net</u>	<u>Gross</u>
A001	63470	Gasket for exhaust for R24-R60/2	1,18 €	1,40 €
A002A	3003	Exhaust nut cover for BMW R24-R60/2, aluminum (slips over the existing nut)	22,65 €	26,95 €
A002B	90111	Exhaust nut for BMW R24-R27 and R50S	23,53 €	28,00 €
A002C	90250	Exhaust nut for BMW R68, R69 and R69S	23,53 €	28,00 €
A003A	9016	Exhaust nut for BMW R24-R27 and R51/2-R60/2	9,45 €	11,25 €
A003B	90110	Exhaust nut for BMW R24-R60/2 stainless steel	21,81 €	25,95 €
A004B	1335595	Exhaust nut for BMW R45 and R65 (fits also on R68, R69 and R69S)	19,37 €	23,05 €
A006	9001	Exhaust pipe clamp for BMW R24-R25/2, R26/R27, all 2 Cylinder until 1969, R45/R65, 36mm head pipe chrome plated	6,39 €	7,60 €
A007	3036	Exhaust pipe clamp for for BMW R25/3 chrome plated	6,39 €	7,60 €
A008A	92038	Exhaust pipe wrench for BMW R24-R60 for vehicle tool kit 17cm	10,08 €	12,00 €



A009	90139	Wrench for finned exhaust nut forged steel, professional workshop quality	23,53 €	28,00 €
A010A	90114	Exhaust pipe for BMW R20, R23 and R24 (with bend)	120,97 €	143,95 €
A010B	90116	Exhaust pipe for BMW R25 and R25/2	120,97 €	143,95 €
A010C	90018	Exhaust pipe for BMW R25/3 (thin)	103,53 €	123,20 €
A010D	11035	Exhaust pipe for BMW R26	120,97 €	143,95 €
A010E	11036	Exhaust pipe for BMW R27	120,97 €	143,95 €
A011AA	62120	Exhaust pipes for BMW R50-R60/2, Set with cross tube stainless steel	377,31 €	449,00 €
A011B	200351	Exhaust pipe for BMW R51/2-R67/3 until year of manufacture 09/1953, right side straight version	125,97 €	149,90 €
A011B	20035	Exhaust pipe for BMW R51/2-R67/3 until year of manufacture 09/1953, left side straight version	125,97 €	149,90 €
A011C	190351	Exhaust pipe for BMW R51/2-R67/3 from year of manufacture 09/1953, right side bent version	125,97 €	149,90 €
A011C	19035	Exhaust pipe for BMW R51/2-R67/3 from year of manufacture 09/1953, left side bent version	125,97 €	149,90 €
A011D	9130351	Exhaust pipe for BMW R68 until year of manufacture 09/1953, right side straight version	125,80 €	149,70 €
A011D	913035	Exhaust pipe for BMW R68 until year of manufacture 09/1953, left side straight version	125,80 €	149,70 €
A011E	130351	Exhaust pipe for BMW R68 from year of manufacture 09/1953, right side bent version	125,80 €	149,70 €
A011E	13035	Exhaust pipe for BMW R68 from year of manufacture 09/1953, left side bent version	125,80 €	149,70 €
A011F	090016	Exhaust pipe for BMW R69 and R69S, right side	120,97 €	143,95 €
A011F	62122	Exhaust pipe for BMW R69 and R69S, Set with crosspipe stainless steel	394,12 €	469,00 €
A011F	15035	Exhaust pipe for BMW R69 and R69S, left side	120,97 €	143,95 €
A011G	140351	Exhaust pipe "conversion" new engine, right /2 frame - earls fork frame	120,97 €	143,95 €
A011G	14035	Exhaust pipe "conversion" new engine, left /2 frame - earls fork frame	120,97 €	143,95 €
A020A	90142	Exhaust pipe bracket for BMW R25/3	13,44 €	15,99 €
A020B	90143	Exhaust pipe bracket for BMW R26	13,40 €	15,95 €
A020C	90141	Exhaust pipe bracket for BMW R27	6,64 €	7,90 €
A021A	2036	Exhaust pipe clamp for BMW R25/3 30mm, chrome plated	6,39 €	7,60 €
A021B	10361	Exhaust pipe clamp for BMW R26 and R27 chrome plated	6,39 €	7,60 €
A021C	90103	Exhaust pipe clamp for BMW R25, R25/2 and R51/2-R69S stainless steel	6,39 €	7,60 €
A025A	22035	Crosspipe for BMW R51/2-R69S chromed	15,80 €	18,80 €
A025B	22036	Crosspipe for BMW R51/2-R69S stainless steel	17,90 €	21,30 €
A027A	900051	Muffler for BMW R51/3-R68, fish-tail with cut out, right side from year of manufacture 09/1953	167,98 €	199,90 €
A027A	90005	Muffler for BMW R51/3-R68, fish-tail with cut out, left side from year of manufacture 09/1953	167,98 €	199,90 €
A027B	900061	Muffler for BMW R51/2-R68, fish-tail with bracket, right side until year of manufacture 09/1953	142,77 €	169,90 €
A027B	90006	Muffler for BMW R51/2-R68, fish-tail with bracket, left side until year of manufacture 09/1953	142,77 €	169,90 €
A027C	90000	Muffler for BMW R20 and R24, fish-tail shape	142,77 €	169,90 €
A027D	90007	Muffler for BMW R25, fish-tail shape	142,77 €	169,90 €
A027E	1034	Muffler for BMW R35 pre war, fish-tail shape	141,93 €	168,90 €
A027F	90012	Muffler for EMW, long	121,85 €	145,00 €
A028A	90021	Muffler for BMW R51/3-R68, bird-tail shape with cut out, right side from year of manufacture 09/1953	167,98 €	199,90 €
A028A	90002	Muffler for BMW R51/3-R68, bird-tail shape with cut out, left side from year of manufacture 09/1953	167,98 €	199,90 €
A028B	900031	Muffler for BMW R51/2-R68, bird-tail with bracket, right side until year of manufacture 09/1953	142,77 €	169,90 €
A028B	90003	Muffler for BMW R51/2-R68, bird-tail with bracket, left side until year of manufacture 09/1953	142,77 €	169,90 €
A028C	90004	Muffler for BMW R25/2, bird-tail shape	142,77 €	169,90 €
A028D	90009	Muffler for BMW R25/3, bird-tail shape	142,77 €	169,90 €
A029A	90001	Muffler for BMW R51/3-R68, Torpedo-shape with cut out, with seam, right side from year of manufacture 09/1953	167,98 €	199,90 €
A029A	4090033	Muffler for BMW R51/3-R68, Torpedo-shape with cut out, without seam, right side from year of manufacture 09/1953	176,39 €	209,90 €
A029B	92001	Muffler for BMW R51/3-R68, Torpedo-shape with cut out, with seam, left side from year of manufacture 09/1953	167,98 €	199,90 €
A029B	4090032	Muffler for BMW R51/3-R68, Torpedo-shape with cut out, without seam, left side from year of manufacture 09/1953	176,39 €	209,90 €
A029C	90008	Muffler for BMW R25/3, torpedo-shape WITHOUT clamp Please order seperatly articel nr: 3036 - clamp for muffler	107,56 €	128,00 €
A030	11088	Muffler-Set for BMW R50, R50/2, R60 and R60/2 stainless steel	461,30 €	548,95 €
A030A	90011	Muffler for BMW R26 and R27, with seam	180,59 €	214,90 €
A030A	4090011	Muffler for BMW R26 and R27, without seam	188,99 €	224,90 €
A030B	900871	Muffler for BMW R50, R50/2, R60 and R60/2, without seam, left side	188,99 €	224,90 €
A030B	90087	Muffler for BMW R50, R50/2, R60 and R60/2, without seam, right side	188,99 €	224,90 €
A030BA	91088	Muffler for BMW R50, R50/2, R60 and R60/2, with seam, left side	184,79 €	219,90 €
A030BA	91087	Muffler for BMW R50, R50/2, R60 and R60/2, with seam, right side	184,79 €	219,90 €



A030BS	4090073	Exhaust pipe for BMW R50S, with finned exhaust nut, left side chrome-plated	121,85 €	145,00 €
A030BS	4090074	Exhaust pipe for BMW R50S, with finned exhaust nut, right side chrome-plated	121,85 €	145,00 €
A030C	900891	Muffler für BMW R50S, R69 and R69S, without seam, left side	197,44 €	234,95 €
A030C	90089	Muffler for BMW R50S, R69 and R69S, without seam, right side	197,44 €	234,95 €
A030CA	90090	Muffler for BMW R50S, R69 and R69S, with seam, left side	188,99 €	224,90 €
A030CB	900901	Muffler für BMW R50S, R69 and R69S, with seam, right side	188,99 €	224,90 €
A030CD	11070	Muffler-Set for BMW R50S, R69 and R69S stainless steel	461,34 €	548,99 €
A030D	90088	Muffler "Conversion" for BMW post-1969 engines at 1955-1969 swing typ frames left side, 38mm, R69S-shape	188,99 €	224,90 €
A030D	900881	Muffler "Conversion" for BMW post-1969 engines at 1955-1969 swing typ frames right side, 38mm, R69S-shape	188,99 €	224,90 €
A030DD	62024	Exhaust pipes "conversion" for BMW motor R50/5-R80, swing typ frame from 1955-1969 38mm, set with crosspipe, stainless steel	327,23 €	389,40 €
A030DD	1451844	Exhaust pipe Set for BMW R80G/S and R80ST until year of manufacture 1987 stainless steel, polished - NOT for paralever!!!	242,86 €	289,00 €
A031	7035	Muffler for BMW R50-R69S, sports-shape, NOT ECE approved, left side	151,18 €	179,90 €
A031	1007035	Muffler for BMW R26 and R27, sports-shape, NOT ECE approved	151,18 €	179,90 €
A031A	87035	Muffler for BMW R50-R69S, sports-shape, NOT ECE approved, right side	151,18 €	179,90 €
A038a	90144	Silent block for muffler holder for BMW R27	9,16 €	10,90 €
A038B	80138	Exhaust mounting rubber for BMW R25/3 and R26	1,85 €	2,20 €
A038C	90131	Distance sleeve for muffler holder for BMW R26	3,53 €	4,20 €
A042	90254	Exhaust thrust ring for BMW R68, R69 and R69S	5,80 €	6,90 €
A043	90258	Exhaust clamp ring for BMW R68, R69 and R69S	7,48 €	8,90 €
A11A1	1090073	Exhaust Pipe for BMW R50 and R50/2, left side	120,97 €	143,95 €
A11A2	1090074	Exhaust Pipe for BMW R50 and R50/2, right side	120,97 €	143,95 €
A11A3	4090048	Exhaust Pipe for BMW R60 and R60/2, left side	120,97 €	143,95 €
A11A4	4090049	Exhaust Pipe for BMW R60 and R60/2, right side	120,97 €	143,95 €



Group E: Electrics

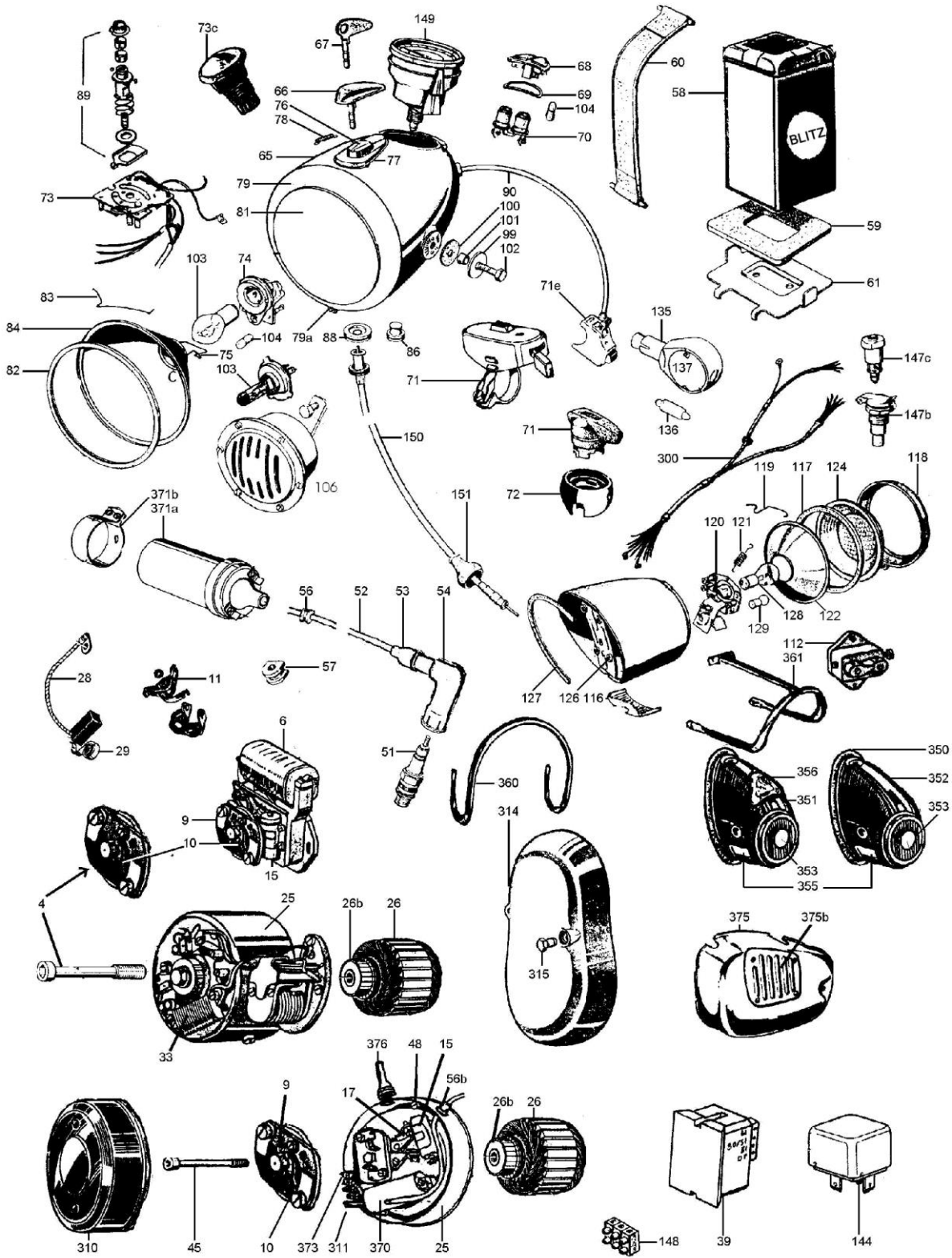

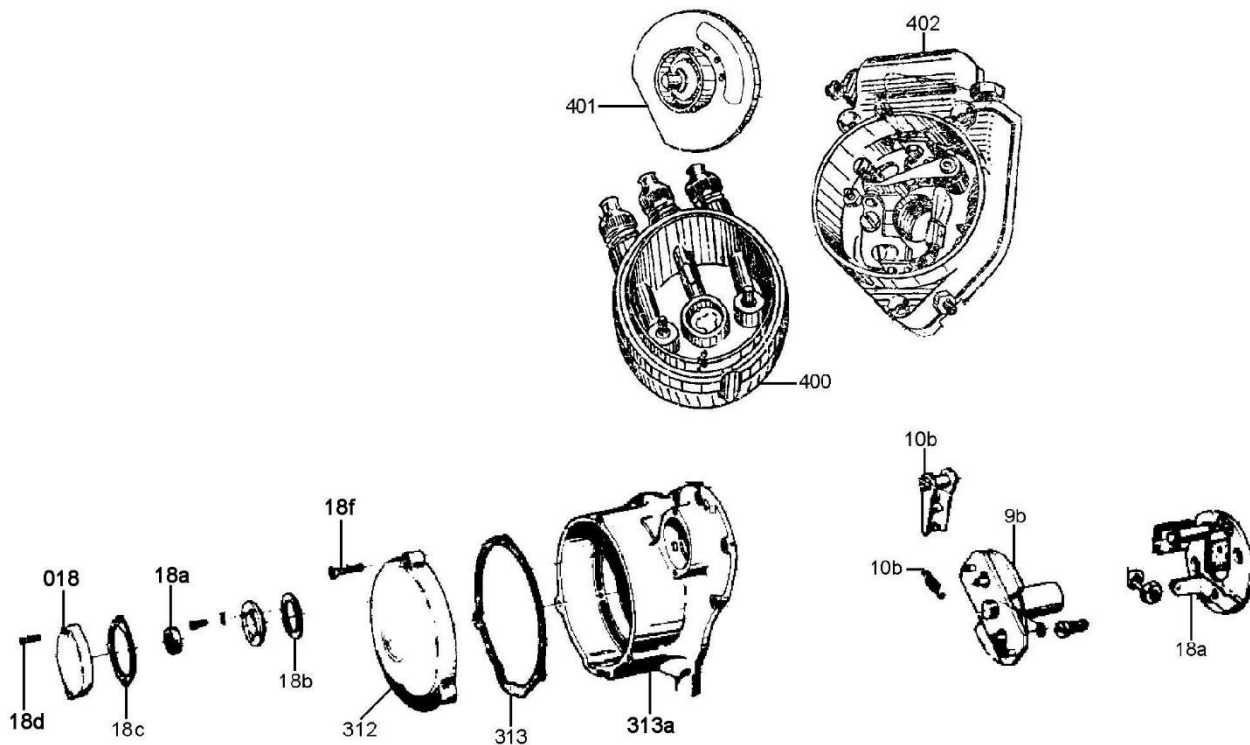

<u>Picture-No.</u>	<u>Article-No.</u>	<u>Description</u>	<u>Net</u>	<u>Gross</u>
E000	270080	Isolating tube, 8mm price per meter	0,97 €	1,15 €
E000	00111	Chrome rim 130mm, Hella-headlight p.e. XT 500, NSU	21,43 €	25,50 €
E000	1259321	Taillight Hella universal, red/orange, small legal for BMW-models until year of manufacture 1980, REMNANTS	18,07 €	21,50 €
E000	2247001	Taillight socle for Hella universal plastic, black	8,57 €	10,20 €
E000	1000666	Ignition timing lamp (Stroboscopic light)	39,33 €	46,80 €
E000	1081120	Contactless ignition system EZA-1, for BMW R24-R26 conversion-kit complete	208,40 €	248,00 €
E000	1301470	Contactless ignition system EZA-2, for BMW R27 conversion-kit complete	216,81 €	258,00 €
E000	1091122	Contactless ignition system EZA-4, for BMW R51/3-R69S (NOT FOR R68 and R69!!!) conversion-kit complete w.high power ignition coil	294,03 €	349,90 €
E0001	7770004	Sticker old BOSCH-Logo for battery 0811	6,30 €	7,50 €
E004A	02108	Generator rotor screw for BMW R24, R25 - R26	4,33 €	5,15 €
E004B	02142	Generator rotor screw for BMW R27	3,36 €	4,00 €
E004C	36184	Generator rotor screw for BMW R51/3-R69S	4,12 €	4,90 €
E004E	8002314	Generator rotor screw for BMW R51/3-R69S, 12V, 100W 4-Brushes, direct current generator	4,16 €	4,95 €
E006	04104	Ignition coil for BMW R51/3-R68 and R50-R69S internal	82,35 €	98,00 €
E008	118031	Magneto rotor for BMW R51/3-R60/2 and R69S, checked used, NOT FOR BMW R68 and R69	119,83 €	142,60 €
E009A	08112	Ignition advance unit for BMW R24-R26	132,77 €	158,00 €
E009b	30147	Ignition advance unit for BMW R27	166,39 €	198,00 €
E009C	04113	Ignition advance unit for BMW R51/3-R69S	166,39 €	198,00 €
E009Ca	0000068	Stop spring for ignition advance unit old version	8,61 €	10,25 €
E009Cb	0000069	Stop spring for ignition advance unit new version	5,80 €	6,90 €
E010A	1018	Spring for ignition advance unit for BMW R24-R69S	2,27 €	2,70 €
E010B	3018	Spring for ignition advance unit for BMW R27	2,44 €	2,90 €
E010C	98481	Lock ring ignition advance unit for BMW R51/3-R69S	0,10 €	0,12 €
E011	3014	Ignition point set for BMW R27	8,36 €	9,95 €
E011	1015	Ignition point set for BMW R51/2	10,50 €	12,50 €
E011	4014	Ignition point set for BMW R51/3-R69S	7,02 €	8,35 €
E011	8530576	Washer set for Ignition point insulation f8r BMW R24-R69S Set = 2 pieces	2,48 €	2,95 €
E011A	2014	Ignition point set for BMW R24-R26	7,52 €	8,95 €
E011AA	32815	Lock ring breaker contact and ignition advance unit for BMW R24-R26	0,08 €	0,10 €
E011F	0000230	Felt for ignition point to adapt for BMW R51/3-R69S	5,88 €	7,00 €
E011G	0001925	Felt for ignition point to adapt for BMW R24, R25, R25/2, R25/3 and R26	5,88 €	7,00 €
E015	8011	Condenser for BMW R24-R69S, with cable and bracket	5,00 €	5,95 €
E015B	98011	Condenser for BMW R24-R69S, without cable - with bracket to solder	3,61 €	4,30 €
E017	98100	Screw M 3,5 x 5, cylinder-head slotted e.g. for generator brush, Ignition points base 1-Cylinder	0,13 €	0,15 €
E017	30008	Ignition point baseplate for BMW R24-R26	24,54 €	29,20 €
E018	0002122	Cover for breaker contact for BMW R27	25,13 €	29,90 €
E018	98174	Screw M 6 x 30, countersunk head	0,34 €	0,40 €



E018	02128	Gasket ignition point baseplate for BMW R27	1,26 €	1,50 €
E018	98101	Screw for ignition point cover for BMW R27, M 4 x 25, cylinder-head cross slotted	0,25 €	0,30 €
E018	02129	Radial seal ring camshaft for BMW R27	3,53 €	4,20 €
E018	30132	Ignition point baseplate for BMW R27 new, original BMW, REMNANTS	151,22 €	179,95 €
E018	02123	Gasket for ignition point cover for BMW R27	1,43 €	1,70 €
E018a	1002127		16,39 €	19,50 €
E025	8002139	Stator with winding for BMW R24, R25, R25/2, R25/3 and R26, 6V rebuilt	327,73 €	390,00 €
E025	8002138	Stator with winding for BMW R24, R25, R25/2, R25/3 and R26, 6V NEW	310,92 €	369,99 €
E025A	5030	Generator winding repair price on a time and material basis	273,11 €	325,00 €
E025a	8002143	Stator with winding for BMW R27, 6V rebuilt	357,14 €	425,00 €
E026	4022	Rotor for Generator for BMW R24-R26, 6 Volt direct current	155,63 €	185,20 €
E026	5022	Rotor for Generator for BMW R50/2, R60/2, R50S and R69S, 6 Volt 20mm, crank pin, large conus	155,63 €	185,20 €
E026	6022	Rotor for Generator for BMW R51/3-R68, R50-R69, 6 Volt 17mm, crank pin, small conus	155,63 €	185,20 €
E026	4023	Rotor for Generator for BMW R27, 6 Volt direct current	155,63 €	185,20 €
E026B	02330	Collector for direct-current rotor	23,53 €	28,00 €
E026D	3022	Generator rotor 6 Volt or 12 Volt Behörde - in exchange Please indicate the type of motorcycle !	218,49 €	260,00 €
E028	98100	Screw M 3,5 x 5, cylinder-head slotted e.g. for generator brush, Ignition points base 1-Cylinder	0,13 €	0,15 €
E028A	02218	Generator brush pre-war-models up to BMW R51/2	4,37 €	5,20 €
E028B	1019	Generator brush for BMW R24-R69S	2,10 €	2,50 €
E028B	8002106	Generator brush Set, 6V for Noris generator central connected, straight end	10,84 €	12,90 €
E028C	02332	Generator brush for BMW R50/2, R60/2 and R69S, 12V, for 4-brushes generators	4,79 €	5,70 €
E028D	02310	Generator brush for BMW R50-R69S, 6Volt 75W, 2-brush-version	2,48 €	2,95 €
E029	7013	Generator brush spring for BMW R24-R69S	2,44 €	2,90 €
E033	1021	Resistor generator for BMW R51/3-R69S, electronic	7,31 €	8,70 €
E039A	6030	Voltage regulator 6V for BMW R24, R25, R25/2, R25/3 and R26, internal electronic, with 4 mounting holes	77,14 €	91,80 €
E039AA	96030	Voltage regulator 6V for BMW R51/2-R69S, internal electronic, with 2 mounting holes	77,14 €	91,80 €
E039C	2009	Voltage regulator 14,3V for BMW R50/5-R100 alternating current (AC)	33,53 €	39,90 €
E039E	976030	Voltage regulator 12V for direct current (DC) electronic	81,26 €	96,70 €
E039F	08106	Voltage regulator 6V for BMW R27 electronic	79,16 €	94,20 €
E045	04100	Locking screw for ignition advance unit for BMW R51/3-R69S	4,12 €	4,90 €
E045D	02348	Generator rotor screw for BMW R50/5-R100	4,96 €	5,90 €
E048	98138	Screw M 5 x 16, cylinder-head, slotted also for headlight rim	0,13 €	0,15 €
E048	98165	Screw M 6 x 16, cylinder-head Allen® key	0,17 €	0,20 €
E051	158158	Spark plug W240T2 for BMW R50-R60/2 long thread	3,19 €	3,80 €
E051	76330	Spark plug W240T1 for BMW R24-R27 and R51/2-R60 short thread	3,19 €	3,80 €
E051	36168	Spark plug W200T30 for BMW R75/5-R80/7, R90/6, R90S R100 until year of manufacture 1979, R80 (all), R100R and GS	3,19 €	3,80 €
E051	61280	Spark plug W230T30 for BMW R50/5-R60/7, R90S, R45/R65 and R100 from year of manufacture 1979	3,19 €	3,80 €
E051	36166	Spark plug W260T1 for BMW R68, R50S, R69 and R69S short thread	3,19 €	3,80 €
E051	36167	Spark plug for BMW R68, R50S, R69 and R69S long thread	4,12 €	4,90 €
E051	32518	Spark plug BOSCH W78G, 4-electrodes short thread	8,28 €	9,85 €
E052	4017	Ignition cable per meter	2,48 €	2,95 €
E053	8036100	Grommet spark-plug socket for BMW R24-R69S	0,84 €	1,00 €
E054	5005	Spark plug socket	6,68 €	7,95 €
E054	5590014	Spark plug socket for BMW R24-R69S with BMW logo	24,20 €	28,80 €
E054	5005011	Spark plug socket, NOT fitted with noise suppression	4,16 €	4,95 €
E055	10272	Ignition cable sleeve, brass, screwable	1,26 €	1,50 €
E056	36150	Grommet ignition cable for BMW R51/3-R68 and R50-R69S	0,88 €	1,05 €
E056	70106	Grommet ignition cable / generator for BMW R25, R25/2, R25/3 and R26	1,81 €	2,15 €
E056P	99910	Battery cover for 6V, 12AH	8,19 €	9,75 €
E057	70195	Grommet wiring harness / generator for BMW R27	0,59 €	0,70 €
E057	52095	Grommet wiring harness / engine for BMW R51/3-R69S, horse-shoe-shape	2,77 €	3,30 €
E058	92124	Battery 6V, for DKW, NSU-Max (fow own filling with acid) black	35,97 €	42,80 €
E058	0092030	Battery 6V, for BMW R26 and R27, black maintenance-free - No shipment outside the European Union possible!	46,64 €	55,50 €
E058	0050512	Battery 12V, for BMW R27-conversation, R50-R69S maintenance-free – No shipment outside the European Union possible!	39,87 €	47,45 €
E058	1001611	Battery 6V, for BMW R50-R69S (US-version), black maintenance-free – No shipment outside the European Union possible!	55,04 €	65,50 €
E058	6123024	Battery 6V, for BMW R24-R25/3, R51/2-R69S, black maintenance-free – No shipment outside the European Union possible!	46,64 €	55,50 €
E058	1101611	Battery 6V, for Panther, Triumph, Velocette maintenance-free – No shipment outside the European Union possible!	55,04 €	65,50 €
E058	1201611	Battery 6V, for Ducati, Gilera, Moto Guzzi maintenance-free – No shipment outside the European Union possible!	55,04 €	65,50 €



E058	1301611	Battery 6V, for Harley-Davidson WLA and WLC maintenance-free – No shipment outside the European Union possible!	55,04 €	65,50 €
E058	1401611	Battery 6V, for Jawa maintenance-free – No shipment outside the European Union possible!	55,04 €	65,50 €
E058	1501611	Battery 6V, for BSA/B.S.A, Matchless maintenance-free – No shipment outside the European Union possible!	55,04 €	65,50 €
E058A	6121024	Battery 6V, for BMW R24-R25/3, R51/2-R68, R50-R69S, black (for own filling with acid)	44,12 €	52,50 €
E058AB	81024	Battery 6V, for BMW R24-R25/3, R51/2-R69S, white (for own filling with acid)	30,88 €	36,75 €
E058B	01411	Battery 6V, for BMW R50-R69S (US-version), black (for own filling with acid)	51,68 €	61,50 €
E058C	3024	Battery 12V, for 12V-conversation, 12N5.5-3B (for own filling with acid) – (white), REMNANTS	29,33 €	34,90 €
E058DA	42030	Battery 6V, for BMW R26 and R27 (for own filling with acid) black	44,71 €	53,20 €
E058E	4024	Battery 12V, for 12V-conversation (for own filling with acid) - (white)	35,63 €	42,40 €
E058J	00386	Battery 6V, for BMW R50-R69S (US-version) (for own filling with acid) - (white)	40,46 €	48,15 €
E058M	29240	Battery acid, 1 litre-bottle will not be shipped - ONLY for pick up in Shop	4,16 €	4,95 €
E058N	96009	Battery charger, automatic, 2V, 6V, 12V, 600mA	16,72 €	19,90 €
E058O	92024	Battery 6V, for DKW, NSU-Max (for own filling with acid) - (white)	35,97 €	42,80 €
E059A	42109	Battery support (foam rubber) for BMW R24-R25/3, R51/2-R69S 74x88 mm	2,14 €	2,55 €
E059B	42211	Battery support (foam rubber) for 6V16Ah battery, foam rubber, for BMW R50-R69S US-Version 80x115mm	2,98 €	3,55 €
E059C	042111	Battery support (foam rubber) for 6V12Ah Battery for BMW R26 and R27 110x50mm	2,98 €	3,55 €
E060A	30016	Battery strap for BMW R24-R25/3, R50-R69S rubber 250mm	4,87 €	5,80 €
E060B	31016	Battery strap for BMW R26 and R27 rubber 190mm	4,87 €	5,80 €
E060C	32016	Battery strap for BMW R51/3-R68 from year of manufacture 09/1953 rubber 270mm, "short version"	4,87 €	5,80 €
E060D	42224	Battery strap for BMW R51/2-R68 until year of manufacture 09/1953 stainless steel black coated, set with 2 pieces	35,21 €	41,90 €
E060E	29016	Battery strap for BMW R51/2-R68, until year of manufacture 09/1953 rubber 350mm, "long version"	4,87 €	5,80 €
E061A	42212	Battery carrier for BMW R50-R69S, 6 Volt	18,49 €	22,00 €
E061AA	42213	Battery carrier for BMW R50-R69S, 6V16Ah, US-Version also suitable for 12V batteries	18,49 €	22,00 €
E061B	42121	Battery carrier for BMW R25, R25/2 and R25/3 powdercoated, black	33,61 €	40,00 €
E065	50030	Headlight bucket for BMW R26, R27 and R51/3-R69S from year of manufacture 09/1953	145,29 €	172,90 €
E065A	50012	Headlight bucket for BMW R25/2 and R51/3-R68 until year of manufacture 09/1953 black, plastik-coated, high gloss	145,29 €	172,90 €
E065C	50013	Headlight for BMW R25/2 and R51/3-R68 until year of manufacture 09/1953, complete WITHOUT speedometer, black	436,97 €	519,99 €
E065D	50032	Headlight for BMW R26, R27 and R51/3-R69S from year of manufacture 09/1953, complete WITHOUT speedometer	436,97 €	519,99 €
E065E	5001253	Headlight for BMW R25/3, complete, WITHOUT speedometer, black refurbished original bucket with new parts, high-gloss finished	436,97 €	519,99 €
E065F	00033	Repairplate contact disk / lamp for BMW R25-R75/5	20,97 €	24,95 €
E066	48116	Ignition key for BMW R25, R25/2 and R51/2-R68 until year of manufacture 1953 black	10,04 €	11,95 €
E066	48111	Ignition key for BMW R24, "Hella"-shape	13,82 €	16,45 €
E066	8014	Ignition key for BMW R25/3-R75/5	6,01 €	7,15 €
E067	48117	Ignition key for BMW R25, R25/2 and R51/2-R68 until year of manufacture 1953 metal version	10,00 €	11,90 €
E067	48119	Ignition key for BMW R25/3-R75/5 metal version	5,80 €	6,90 €
E068A	48129	Indicator control lens neutral for BMW-models until year of manufacture 1954, green true to original	9,66 €	11,50 €
E068B	5013	Ignition control lense red/green for BMW R25/3-R69S	14,03 €	16,70 €
E068C	48131	Indicator control lens driving light for BMW R50/5, R60/5 and R75/5, blue	9,66 €	11,50 €
E068D	48135	Ignition control lense red, years 1950-1954	13,19 €	15,70 €
E069	48128	Ignition control lense gasket for BMW R25/3-R69S for the red/green ignition control lense (articelnr. 5013)	1,93 €	2,30 €
E070	0000001	Screw for original controllight-assembly red/green, M 3 x 4, flat-head slotted for BMW R25/3-R27 and R50-R69S	0,21 €	0,25 €
E070	0000002	Screw for original controllight-assembly red/green, M 3 x 5, flat-head slotted for BMW R25/3-R27 and R50-R69S	0,21 €	0,25 €
E070A	8048129	Bulb holder for red/green lens for BMW R25/3-R69S, original metal-version	16,72 €	19,90 €
E071	19360	Grommet light switch for BMW R25/2-R27 and R51/3-R69S, BOSCH-shape	2,02 €	2,40 €
E071	48163	Lightswitch, BOSCH-form chromed	80,25 €	95,50 €
E071	8048161	Dimmer switch mechanical for BMW R25, R51 (1938) for clutch control black	64,45 €	76,70 €
E071	8402540	Screw M 2,5 x 4, cylinder-head, slotted e.g. for light and indikator switch	0,80 €	0,95 €
E071AA	2072183	Switch holder for BMW R26-R69S, for indicator switch (left side), round for hanging, REMNANTS	32,77 €	39,00 €
E071B	48183	Direction indicator switch for BMW R27-R69S, black REMNANTS !	85,38 €	101,60 €
E071C	20013	Lightswitch (HiLo switch), universal with horn button chromed	9,41 €	11,20 €
E071D	20014	Direction indicator switch universal with clamp chromed	10,76 €	12,80 €
E071H	48182	Direction indicator switch, original shape, to hinge in the armature chromed	80,25 €	95,50 €



E071J	30441	Indicator-switch adaptor for BMW R26-R69	4,75 €	5,65 €
E072	07450	Screw for switch bracket round, lateral	3,78 €	4,50 €
E072	0007451	Screw for switch bracket round, centric	0,25 €	0,30 €
E072A	40110	Indicator-switch adaptor for BMW R27, R50/2, R60/2 and R69S, round	18,49 €	22,00 €
E073A	3001	Contact plate for BMW R25/3-R69S	97,14 €	115,60 €
E073B	48176	Contact plate for BMW R25-R25/2 and R51/2-R68 for electric dip-switch	97,14 €	115,60 €
E073C	48154	Fuse holder for BMW R25, R25/2 and R51/2-R68 with chrom frame	15,13 €	18,00 €
E074A	48179	Bulb holder for BMW R24-R69S for BOSCH-reflector	14,20 €	16,90 €
E074B	80130	Bulb holder single-pole for position light with H4, socket BA9S	3,49 €	4,15 €
E075	50160	Bulb holder-clip for BOSCH-reflector	1,90 €	2,26 €
E076	9013	Ignition cover slide for BMW R25/3-R27, R51/3, R67/3, R68 and R50-R69S	3,70 €	4,40 €
E077	48189	Cover for ignition switch, single	12,61 €	15,01 €
E077A	6013	Cover for ignition switch set complete with spring and sliding cover	17,23 €	20,50 €
E078	48191	Spring for ignition cover slide for BMW R25/3-R27, R51/3, R67/3, R68 and R50-R69S	1,05 €	1,25 €
E079A	2013	Chrome rim for BMW R24-R69S, Head light	16,81 €	20,00 €
E079B	92013	Chrome rim for BMW R24, Hella shape, Headlight	18,07 €	21,50 €
E079C	20131	Chrome rim for BMW R24-R69S, Head light with Logo	27,52 €	32,75 €
E080	50185	Screw for headlight chrome rim and dual seat railing for BMW R50/5, R60/5 and R75/5 M 5 x 16	0,21 €	0,25 €
E081	12013	Headlight lens "H4" for BMW R24-R75/5 and R45/R65 until year of manufacture 09/1984, front, BOSCH	22,65 €	26,95 €
E081	5603004	Headlight lens for BMW R24-R69S, BOSCH "old" style lettering	24,33 €	28,95 €
E081A	8007	Headlight lens for BMW R24-R69S	24,33 €	28,95 €
E081B	11013	Headlight lens "H4" for BMW R24-R75/5 and R45/R65 until year of manufacture 09/1984, ZEV	10,00 €	11,90 €
E082	1007	Headlight lens gasket for BMW R24-R75/5, front	1,85 €	2,20 €
E083	48181	Headlight clip	0,50 €	0,60 €
E084	50181	Reflector headlight for BMW R24-R69S, BOSCH-form	18,49 €	22,00 €
E084C	08018	H4-plug base, also as indicator plug base for BMW R50-R100	6,22 €	7,40 €
E086	2008	Grommet wiring harness / shell for BMW R24-R69S	0,97 €	1,15 €
E087	9009	Rubber plug for blinker wire / headlight for BMW R26, R27 and R51/3-R68 from year of manufacture 09/	0,88 €	1,05 €
E087	70199	Grommet lightswitch / headlight for BMW R24-R69S	0,63 €	0,75 €
E087	70188	Grommet horn / headlight for BMW R25/3	0,76 €	0,90 €
E088	19007	Grommet speedocable / headlight for BMW R24-R69S and for revolution counter cable/headlight for BMW R50/5-R75/5	1,64 €	1,95 €
E089	1013	Ignition lock assembly for BMW R25-R75/5	37,73 €	44,90 €
E090A	190031	Wiring harness, lights/indicator switch for BMW R25/2-R27 and R51/3-R69S 3mm eyes, for chrom plated switch	8,53 €	10,15 €
E090AA	1900311	Wiring harness, lights/indicator switch for BMW R27, R50/2, R60/2 and R69S 2,5mm eyes, for black switch	7,98 €	9,50 €
E090B	4035	Wire, four-core, black price per meter	1,72 €	2,05 €
E090C	4036	Wire, three-core, black price per meter	1,55 €	1,85 €
E090C	8351101	Wire, two-core, black price per meter	1,39 €	1,65 €
E099	50134	Headlight washer stainless steel, polished	3,32 €	3,95 €
E100	8008	Headlight rubber, round (washer) (you need 4 pcs for one Headlight!)	1,26 €	1,50 €
E101	50138	Spacer rubber for headlight ear	1,68 €	2,00 €
E102A	13661	Headlight bolt stainless steel, polished	2,52 €	3,00 €
E103	77224	H4-Headlight insert, 7" for BMW-pre war models	26,81 €	31,90 €
E103	10062	Bulb 6 Volt, 60/55 Watt, Halogen-H4, socket P45T car-socket	13,36 €	15,90 €
E103	8001005	Bulb 6 Volt, LED, socket BA20D, white for Headlight, (replacement for 35/35 Watt) WITHOUT compliance	15,13 €	18,00 €
E103	8001006	Bulb 12 Volt, LED, socket BA20D, white for Headlight, (replacement for 35/35 Watt) WITHOUT compliance	15,13 €	18,00 €
E103	8001008	Bulb 12 Volt, LED, socket PT43, white for Headlight, (replacement for 35/35 Watt) WITHOUT compliance	15,13 €	18,00 €
E103	8001007	Bulb 6 Volt, LED, socket PT43, white for Headlight, (replacement for 35/35 Watt) WITHOUT compliance	15,13 €	18,00 €
E103A	1005	Bulb 6 Volt, 35/35 Watt, socket BA20D	6,64 €	7,90 €
E103AA	78007	Bulb 6 Volt, 45/40 Watt, socket BA20D	6,64 €	7,90 €
E103AB	58148	H4-Headlight insert for BMW R24-R69S WITH 6V, 35/35W bulb	41,93 €	49,90 €
E103B	64185	Bulb 12 Volt, 35/35 Watt, socket BA20D	6,30 €	7,50 €
E103BA	6011	H4-Headlight insert for BMW R24-R69S, R50/5-R75/5, R45 and R65, "plastic-reflector", WITHOUT bulb with bulb-holder and spring	28,49 €	33,90 €
E103BA	6316011	H4-Headlight insert for BMW R24-R69S, R50/5-R75/5, R45 and R65, "metal-reflector", WITHOUT bulb with bulb-holder and spring	28,49 €	33,90 €
E103C	10060	Bulb 6 Volt, 35/35 Watt, Halogen-H4, socket PX43T	11,18 €	13,30 €
E103D	78006	Bulb 12 Volt, 35/35 Watt, Halogen-H4, socket PX43T	7,52 €	8,95 €
E103E	1006	Bulb 6 Volt, 60/55 Watt, Halogen-H4, socket P43T	13,36 €	15,90 €
E103G	1354619	Bulb 12 Volt, 60/55 Watt, Halogen-H4, socket P43T	5,00 €	5,95 €
E103H	10063	Bulb 6 Volt, 25/25 Watt, Halogen-H4, socket BA20D	11,18 €	13,30 €



E103I	10061	Bulb 6 Volt, 35/35 Watt, Halogen-H4, socket BA20D	12,56 €	14,95 €
E103J	1006112	Bulb 12 Volt, 35/35 Watt, Halogen-H4, socket BA20	12,56 €	14,95 €
E104A	2005	Bulb 6 Volt, 2 Watt, socket BA7S e.g. speedo-light	0,97 €	1,15 €
E104A	2005001	Bulb 6 Volt, LED, socket BA7S, white e.g. speedo-light original speedo	2,35 €	2,80 €
E104B	20051	Bulb 6 Volt, 2 Watt, socket BA9S e.g. control-light, sidelight	0,97 €	1,15 €
E104Ba	2005102	Bulb 6 Volt, LED, socket BA9S, green e.g. control-light	2,35 €	2,80 €
E104Bb	2005103	Bulb 6 Volt, LED, socket BA9S, red e.g. control-light	2,35 €	2,80 €
E104Bc	2005101	Bulb 6 Volt, LED, socket BA9S, white e.g. side-light	2,35 €	2,80 €
E104Bc	2005121	Bulb 12 Volt, LED, socket BA9S, white e.g. side-light	2,35 €	2,80 €
E104C	99105	Bulb 6 Volt, LED, Cup-shape for BMW R24	5,46 €	6,50 €
E104D	89001	Bulb 12 Volt, 102/2 Watt, socket BA7S e.g. speedo	0,97 €	1,15 €
E104E	78243	Bulb 6 Volt, 4 Watt e.g. sidelight	0,97 €	1,15 €
E104F	99501	Bulb 12 Volt, 2 Watt, socket BA9S	0,97 €	1,15 €
E104G	99504	Bulb 12 Volt, 4 Watt e.g. position light	0,97 €	1,15 €
E104H	78242	Bulb 6 Volt, 3 Watt e.g. sidelight	0,97 €	1,15 €
E106A	1012	Horn 6 Volt for BMW R24-R69S chromed, (high tone = ca. 420 Hz.)	12,77 €	15,20 €
E106A	1012001	Horn 6 Volt for BMW R24-R69S chromed, (lower tone = ca. 320 Hz.)	12,77 €	15,20 €
E106AA	46015	Horn 6 Volt for BMW R24-R69S black painted	12,77 €	15,20 €
E106B	2072	Horn 12 Volt, Ø 100mm chromed	12,77 €	15,20 €
E112	8070184	Mounting plate for brake light switch article nr. 6005 for BMW R24-R25/3 and R51/2	12,56 €	14,95 €
E112A	6005	Brake light switch, years of manufacture 09/1954-09/1980, rear	5,76 €	6,85 €
E112B	7005	Brake light switch with spring to refit	7,48 €	8,90 €
E112D	8005	Cover cap for Brake light switch, rear	1,51 €	1,80 €
E116	54121	Lense, license-plate for BMW R26, R27 and R50-R69S	3,82 €	4,55 €
E117	948183	Gasket taillight lens for BMW R26-R69S from year of manufacture 09/1958	1,43 €	1,70 €
E118	3016	Chrome rim taillight for BMW R27, R50/2, R60/2 and R69S	11,26 €	13,40 €
E119	54127	Taillight clip for BMW R27 and R50-R69S	0,50 €	0,60 €
E120	54130	Bulb holder tail-light for BMW R27-R69S	22,98 €	27,35 €
E121	54131	Bulb holder spring taillight for BMW R27-R69S	1,30 €	1,55 €
E122	54133	Reflector taillight for BMW R27 and R50-R69S	13,95 €	16,60 €
E124	54136	Lens, tail light for BMW R26, R27 and R50-R69S from year of manufacture 09/1958	8,57 €	10,20 €
E124	8054135	Lens, tail light for BMW R26, R27 and R50-R69S from year of manufacture 09/1958, HELLA	20,88 €	24,85 €
E125A	54111	Taillight for BMW R26, R27 and R50-R69S from year of manufacture 09/1958, big, Hella-shape	102,23 €	121,65 €
E125B	54118	Taillight housing for BMW R26, R27 and R50-R69S from year of manufacture 09/1980 black painted	51,18 €	60,90 €
E126	88552	Grommet taillight for BMW R26, R27 and R50-R69S	0,46 €	0,55 €
E127	43809	Gasket taillight lens fender for BMW R26-R69S from year of manufacture 09/1958	1,60 €	1,90 €
E128A	3005	Bulb 6 Volt, 21/5 Watt	2,06 €	2,45 €
E128AA	3005001	Bulb 6 Volt, LED, socket BAY15D, red/white, small and big Hella Taillight replaces 21/5 Watt bulb	12,14 €	14,45 €
E128B	78381	Bulb 12 Volt, 21/5 Watt, socket BA15D	2,10 €	2,50 €
E129	2005201	Bulb 6 Volt, LED, socket BA15S, white alternative for 5 Watt to 21 Watt wire-bulb	4,96 €	5,90 €
E129A	99506	Bulb 6 Volt, 5 Watt, socket BA15 e.g. license plate illumination	1,43 €	1,70 €
E129B	99505	Bulb 12 Volt, 5 Watt e.g. license plate illumination	1,39 €	1,65 €
E135	2006	Bar end indicator, Hella (Bull's eye) aluminium polished	51,93 €	61,80 €
E135C	54159	Bar end indicator with 6V bulb and cable aluminium polished	24,54 €	29,20 €
E136A	4005	Bulb 6 Volt, 18 Watt, festoon-bulb e.g. handlebar indicator (Ochsenaugen)	1,85 €	2,20 €
E136B	99503	Bulb 12 Volt, 18 Watt, festoon-bulb	1,85 €	2,20 €
E136B	4005111	Bulb 6 Volt, LED, festoon-bulb 45mm, for handlebar indicator - only suitable with the electronic relay!	8,32 €	9,90 €
E136C	20052	Bulb 6 Volt, 18 Watt, bowl-bulb, socket: round 15mm e.g. for brake light	1,85 €	2,20 €
E136C	4005002	Bulb 6 Volt, LED, festoon-bulb, red 42mm, e.g. "Eber"-taillight	3,95 €	4,70 €
E136CC	2005201	Bulb 6 Volt, LED, socket BA15S, white alternative for 5 Watt to 21 Watt wire-bulb	4,96 €	5,90 €
E136CD	2125201	Bulb 12 Volt, LED, socket BA15S, white alternative for 5 Watt to 21 Watt wire-bulb	4,37 €	5,20 €
E136CE	2125202	Bulb 12 Volt, LED, socket BAY15D, red e.g. taillight, replaces 21/5 Watt bulb	10,46 €	12,45 €
E136D	99502	Bulb 12 Volt, 21 Watt, socket BA15S ball-bulb	1,39 €	1,65 €
E136D	4005001	Bulb 6 Volt, LED, festoon-bulb, white 42mm, e.g. "Eber"-taillight	3,95 €	4,70 €
E136D	4005003		3,95 €	4,70 €
E137	98102	Screw for bar end indicator lens, M 3 x 10	0,08 €	0,10 €
E137A	2011	Bar end indicator lens, "E" approved	6,81 €	8,10 €
E144A	1011	Indicator relay 6V, electronic, also for LED-bulbs also only for 2 barend indicator (green=15, red=49A)	17,65 €	21,00 €
E144A	9991011	Indicator relay 6V, electronic NOT for LED-bulbs	22,31 €	26,55 €
E144B	5009	Indicator relay 12V, electronic, for bar-end indic. - Ochsenaugen	17,65 €	21,00 €
E147A	70109	Male plug, 90° angled	8,82 €	10,50 €
E147A	70110	Male plug, straight	4,96 €	5,90 €



E147B	70111	Female plug for sidecar lighting	7,65 €	9,10 €
E147C	7012	Ground connection for female plug	1,85 €	2,20 €
E147D	7014	Hinged cover for female plug	3,07 €	3,65 €
E147E	90081	Rubber plug for plug socket hole for BMW R25-R69S	1,43 €	1,70 €
E148	50508	Wiring connector 12pc. 6.0	1,85 €	2,20 €
E148	50507	Wiring connector 12pc. 2.5	1,68 €	2,00 €
E149	80034	Speedo 20-140 km/h, gear ratio: 1,0 for BMW R25/3, R26 and R27 WITHOUT BMW logo	99,16 €	118,00 €
E149	80027	Speedo 0-140 km/h, gear ratio: 1,08 for BMW R26 and R27 police model WITHOUT BMW logo	99,16 €	118,00 €
E149	80058	Speedo 0-160 km/h, gear ratio: 0,75 for BMW R50-R69S WITHOUT BMW logo	99,16 €	118,00 €
E149	80043	Speedo 0-160 km/h, gear ratio: 1,15 for BMW R25/3, R51/2, R51/3 and R68 (sidecar) original BMW (Veigel)	215,80 €	256,80 €
E149	080066	Speedo 0-140 km/h, gear ratio: 0,9 for BMW R67 and R67/2 WITHOUT BMW logo	99,16 €	118,00 €
E149	80020	Speedo 0-120 km/h, gear ratio: 1,05 for BMW R25 and R25/2 WITHOUT BMW logo	99,16 €	118,00 €
E149	80045	Speedo 0-160 km/h, gear ratio: 0,95 for BMW R51/2 and R51/3 WITHOUT BMW logo	99,16 €	118,00 €
E149	80082	Speedo 0-120 mph, gear ratio: 1,23 (25:8) for BMW R50-R69S WITHOUT BMW logo	99,16 €	118,00 €
E149	0800881	Speedo VDO, 20-180 km/h, gear ratio: 0,86 for BMW R50S	161,51 €	192,20 €
E149B	0080033	Speedo "oblique connection for speedo cable", 0-140 km/h, gear ratio : 1,0 for BMW models pre-WW2 black instrument dial, neutral	83,99 €	99,95 €
E149DA	80059	Speedo 20-160 km/h, gear ratio: 0,75 for BMW R50-R69S WITHOUT BMW logo	99,16 €	118,00 €
E149G	80076	Speedo 20-200 km/h, gear ratio: 0,75 for BMW R69S WITHOUT BMW logo	99,16 €	118,00 €
E149J	181010	Speedo "oblique connection for speedo cable", 0-160 km/h, gear ratio: 1,00 for BMW models pre-WW2 black instrument dial, neutral	76,68 €	91,25 €
E149JCE	0800885	Speedo VDO, 20-200 km/h, gear ratio: 0,715 for rear drive 32:10	151,26 €	180,00 €
E149JJ	10022	Speedo retaining clip set for speedo "oblique connection for speedo cable"	1,68 €	2,00 €
E149N	80150	Revolution counter for BMW R50-R69S until year of manufacture 05/1965, 1:4	124,37 €	148,00 €
E149NA	80151	Revolution counter for BMW R50, R60/2 and R69S from year of manufacture 06/1965, 1:2	124,37 €	148,00 €
E149NB	80154	Revolution counter cable for BMW R50-R69S, long connected at oil pump	12,86 €	15,30 €
E149NC	0080092	Chrome rim revolution counter for BMW R50-R69S with rubber gasket	12,35 €	14,70 €
E149NC	8080154	Revolution counter cable for BMW R50/2-R69S, short connected at camshaft until year of manufacture 06/1965	24,54 €	29,20 €
E149XA	120021	Chrome rim for speedo for BMW R24-R69S (Veigel) with rubber gasket and for our remanufactured speedos	12,52 €	14,90 €
E149XB	80090	Chrome rim for speedo for BMW R24-R69S with rubber gasket high for VDO speedos	13,19 €	15,70 €
E149XB	8009001		7,48 €	8,90 €
E150	1016	Speedo cable for BMW R26, R27, R50-R69S and R50/5-R75/5 small fixture diameter	11,26 €	13,40 €
E150B	2016	Speedo cable for BMW R24-R25/3 and R51/3-R68 big fixture diameter	11,26 €	13,40 €
E150C	97020	Speedo cable for BMW "pre-war" models	15,08 €	17,95 €
E151	80160	Grommet speedocable / gearbox for BMW R24-R69S and R50/5-R100	1,43 €	1,70 €
E152	80115	Gasket ring for BMW R24-R69S (O-Ring between speedo and shell) and gasket indicator glas for BMW R50/5 and up	1,09 €	1,30 €
E153	80084	Speedo retaining clip for BMW models until year of manufacture 08/1969	1,93 €	2,30 €
E154	22110	Nut for speedo retaining clip for BMW R24-R69S	0,97 €	1,15 €
E156	3011	Bulb holder single-pole, for BMW R24-R69S for VDO-Speedos, socket BA7S and R50/5-R75/5 main beam warning light	3,61 €	4,30 €
E300	1900301	Wiring harness, brakelight/neutralswitch for BMW R25, R25/2 and R25/3	15,04 €	17,90 €
E300	4084518	Grommet wiring harness stoplight / idling for BMW R26 and R27	0,63 €	0,75 €
E300A	4030	Wiring harness for BMW R24-R26	38,65 €	45,99 €
E300B	3030	Wiring harness for BMW R27	55,80 €	66,40 €
E300C	66035	Wiring harness for BMW R50-R69S, 6 Volt	40,76 €	48,50 €
E300D	66015	Wiring harness for BMW R50-R69S, 12 Volt three-phase	51,64 €	61,45 €
E300E	66027	Wiring harness for BMW R51/3-R68, 6 Volt	49,58 €	59,00 €
E300F	190030	Wiring harness, brakelight/neutralswitch for BMW R26 and R27	15,04 €	17,90 €
E300G	66045	Wiring harness for BMW R50-R69S, 12 Volt, direct-current	47,86 €	56,95 €
E300H	8066025	Wiring harness for BMW R51/2	49,58 €	59,00 €
E300i	8066101	Wiring harness, taillight for BMW R25/2-R69S	7,14 €	8,50 €
E301A	9010	Cable tape 150x3,6mm black	0,08 €	0,10 €
E301A	9015	Cable strap 150x3,6mm black	0,13 €	0,15 €
E301B	9017	Cabel strap 200 x 3,6 mm black	0,13 €	0,15 €
E301C	9019	Cable tape 360x7,5mm black	0,42 €	0,50 €
E301D	90190	Cable tape 285 x 4,7	0,17 €	0,20 €
E301D	70232	Clamp, handle bar for BMW R24-R100 (all 22mm handle bars) or frame cross tube, stainless steel	4,62 €	5,50 €
E301E	9019000	Cable tape 300 x 4,6 mm, stainless steel	0,62 €	0,74 €
E309	02172	Generator cover holding angle, Z-shape for BMW R25/3 and R26	11,93 €	14,20 €



E309B	02173	Generator cover holding angle, L-shape for BMW R24, R25 and R25/2 stainless steel	10,00 €	11,90 €
E310A	02112	Generator cover for BMW R24, R25, R25/2, R25/3 and R26 chromed	57,14 €	68,00 €
E310B	02113	Generator cover for BMW R24, R25, R25/2, R25/3 and R26 silver painted	48,74 €	58,00 €
E310B	0211400	Generator cover for BMW R24, R25, R25/2, R25/3 and R26 black painted	48,74 €	58,00 €
E311A	902100	Generator cover bolt for BMW R24, R25, R25/2, R25/3 and R26	2,94 €	3,50 €
E311B	36102	Rubber plug generator for BMW R24-R26 and fork guide for BMW R51/3	0,67 €	0,80 €
E312	116031	Generator cover for BMW R27	61,30 €	72,95 €
E313	5031	Timing cover for BMW R27 used	100,84 €	120,00 €
E313	2116	Gasket generator cover for BMW R27	1,64 €	1,95 €
E314	02187	Generator cover for BMW R50-R69S, 12V three-phase current	116,81 €	139,00 €
E314	117031	Generator cover for BMW R51/3-R69S, 6V used	243,70 €	290,00 €
E314	1002178	Generator cover for BMW R51/3-R68 and R50-R69S, 6 Volt	116,81 €	139,00 €
E314	1002179	Generator cover for BMW R51/3-R68 and R50-R69S, 6 Volt with revolution counter on cam shaft	159,66 €	190,00 €
E315	02191	Generator cover nut for BMW R51/3-R69S, hexagon with locking ring, wrench size 10	5,50 €	6,55 €
E315	9913470	Screw for bearing plate 1-cylinder and alternator cover BMW R51/2, M 6 x 18, hexagon	0,30 €	0,36 €
E350	2003	Rubber pad for Eber-tailight for BMW R25-R25/3 and R51/2-R68	4,03 €	4,80 €
E351	10328	Bulb holder universal with angle, socket BA15S	4,16 €	4,95 €
E351	1030	Taillight Eber-shape for BMW R25/3, R51/3, R67/2, R67/3 and R68 with brakelight orange and pad (external lens on top), black	68,07 €	81,00 €
E351B	1031	Taillight Eber-shape for BMW R25/3, R51/3, R67/2, R67/3 and R68 with brakelight and pad, chromed	81,68 €	97,20 €
E351D	8054111	Taillight for BMW R26, R50, R60 and R69 until year of manufacture 09/1958, small	66,47 €	79,10 €
E352	2030	Taillight Eber-shape for BMW R25, R25/2, R51/2 and R67 with brakelight red and pad (only one lens), black	74,37 €	88,50 €
E352b	054101	Taillight for BMW R24	75,55 €	89,90 €
E353	6354111	Lens, tail light for BMW R26, R50, R60 and R69, small	6,39 €	7,60 €
E353AA	0019003	Lens for "Eber" tail light, red, for BMW R25-R25/3 and R51/2-R68, with aluminium ring and gasket Gasket comes between lens and housing!	14,71 €	17,50 €
E354A	78330	Bulb 6 Volt, 5 Watt, festoon-bulb e.g. Eber-Backlight (driving-light)	1,85 €	2,20 €
E354B	78304	Bulb 12 Volt, 5 Watt, festoon-bulb	1,85 €	2,20 €
E354C	78303	Bulb 6 Volt, 10 Watt, festoon-bulb e. g. Eber-Backlight (breaklight)	1,85 €	2,20 €
E354D	78305	Bulb 12 Volt, 10 Watt, festoon-bulb	1,85 €	2,20 €
E355	99810	Lense, license-plate for Original "Eber" taillight for BMW R25-R25/3 and R51/2-R68	4,20 €	5,00 €
E356	78306	Brake light lens for "Eber"-light	8,32 €	9,90 €
E357D	42179	Battery supporting rubber inside cover for BMW R26 and R27	2,77 €	3,30 €
E360	1052	Headlight guard for BMW R24-R75/5 chromed	16,72 €	19,90 €
E361A	9910521	Taillight guard for BMW R26, R27 and R50-R69S from year of manufacture 09/1958 stainless steel	29,33 €	34,90 €
E370	30000	Ignition coil 6V, for BMW R24-R26 internal	43,57 €	51,85 €
E371a	30025	Ignition coil 6V, for BMW R27 and various other models external, Ø 40mm	23,95 €	28,50 €
E371a	43910	Ignition coil 12V external, Ø 40mm	23,95 €	28,50 €
E371B	30500	Clamp for exterior ignition coil (40mm) for BMW R27	5,46 €	6,50 €
E373	023399	Contact plate generator for BMW R27	19,41 €	23,10 €
E373	02339	Contact plate generator for BMW R24-R26	19,41 €	23,10 €
E375	42170	Gasket for battery cover for BMW R26 and R27	3,19 €	3,80 €
E375	46126	Grommet batterie cover for R26 and R27, horse-shoe-shape	2,10 €	2,50 €
E375A	42162	Battery cover for R26 and R27 with alu step-protector black	86,47 €	102,90 €
E375B	42160	Battery cover protection plate for BMW R26 and R27	19,92 €	23,70 €
E375D	92025	Groove pin for steering-lock cover and stepshield for BMW R26, R27 and R50-R100/7	0,42 €	0,50 €
E375E	98470	Clamp ring, clip-on, 4mm	0,25 €	0,30 €
E376	70194	Grommet wiring harness / generator for BMW R25-R26, long	2,10 €	2,50 €
E400	30168	Distributor cap for BMW R51/2	25,13 €	29,90 €
E401	80176	Distributor rotor for BMW R51/2	20,08 €	23,90 €
E402	02025	Distributor baseplate for BMW R51/2 WITH contact-breaker lateral inversion	30,67 €	36,50 €
E403	80177	Distributor gasket for BMW R51/2	1,93 €	2,30 €
E500	4009	Diode plate for 12V three-phase traction drive-generator	69,75 €	83,00 €
E501A	19030	Distance ring three-phase dynamo for R27	61,36 €	73,02 €
E501B	02003	Distance ring three-phase dynamo for R50-R69S	92,03 €	109,52 €
E503	99082	Battery pole protection grease, 50g	5,46 €	6,50 €
E600	999401	Test light, 6-24 Volt	8,49 €	10,10 €
E999	70224	Grommet wiring harness / battery carrier for BMW R50-R69S	3,78 €	4,50 €
E999	1635700	Radial seal ring, camshaft for BMW R51/3-R69S ONLY for contactless ignition system EZA-4	3,36 €	4,00 €



Group V: Carburetor, airfilter all models 1948-1969

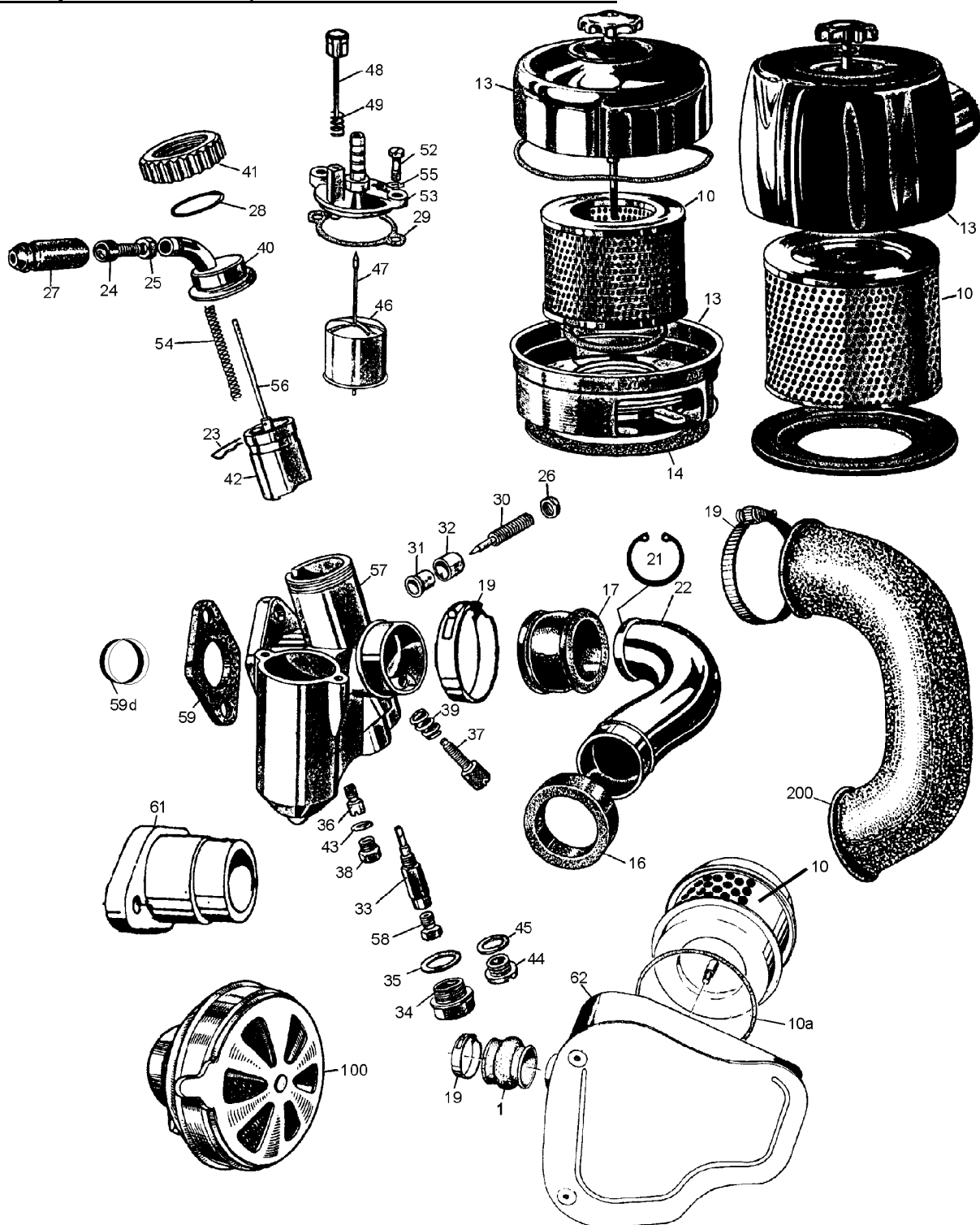

We always need to know the Bing number that is stamped on your carburetor to collect the correct parts.

<u>Picture-No.</u>	<u>Article-No.</u>	<u>Description</u>	<u>Net</u>	<u>Gross</u>
V000	43025	Air filter - wet-type air filter - for BMW R51/2 with throttle flap	75,55 €	89,90 €
V000	10000	Carburettor cleaning in ultrasonic bath	12,77 €	15,20 €
V000	0039290	Accelerator pump complete for BMW R27, Isetta (for 1/26/93) REMNANTS !	50,00 €	59,50 €
V000	80009	Covering disk for fuel cock for BMW R25-R69S	0,42 €	0,50 €
V000	42120	Gasket ring hose connector for BMW R25-R27	0,41 €	0,49 €
V000	42122	Gasket ring for BMW R24-R27 Cover nut for BMW R50/5-R60/7, 53er carburetor	0,41 €	0,49 €
V000	7770001	Sticker "Knecht Micro Star Luffilter for BMW R69S transparent	5,46 €	6,50 €
V000	0043140	Engine breather filter for BMW R51/3-R69S	19,24 €	22,90 €
V000	0043136	Locking spring for engine breather for BMW R51/3-R69S used	3,19 €	3,80 €
V000	9963493	Gasket for engine breather filter for BMW R51/3-R69S	1,64 €	1,95 €
V001	19016	Air filter rubber for BMW R26 and R27	3,82 €	4,55 €
V009	0043151	Air filter base ring for BMW R50S and R69S	33,53 €	39,90 €
V010	1200030	Air filter wired insert R51	70,55 €	83,95 €



V010a	43149	Air filter screw for BMW R26 and R27, short for wet-type air filter cover	12,69 €	15,10 €
V010A	43116	O-ring air filter for BMW R26 and R27	1,85 €	2,20 €
V010A	2048	Air filter insert for BMW R27, R50 and R60 old, small format	9,92 €	11,80 €
V010B	3048	Air filter insert for BMW R50/2, R60/2 and R69S, big format	10,88 €	12,95 €
V012	0043167	Air filter clamping screw for BMW R69S chromed	33,53 €	39,90 €
V013	50314	Air filter housing for BMW R50S and R69S complete with screw and bottom part chromed - WITHOUT inlay and cork gasket	151,26 €	180,00 €
V013	43033	Air filter housing for BMW R50, R50/2, R60 and R60/2 used	134,37 €	159,90 €
V013	3404927	Air filter housing for BMW R27, metal case black, (WITHOUT air filter insert)	124,37 €	148,00 €
V013A	50315	Air filter housing for BMW R50S and R69S complete with screw and bottom part silver painted - WITHOUT inlay and cork gasket	141,18 €	168,00 €
V014	43118	Cork gasket air filter for BMW R51/3-R69S	2,48 €	2,95 €
V014A	0043152	O-ring air filter for BMW R50-R69	4,16 €	4,95 €
V016A	42164	Air filter rubber for BMW R51/2-R67/3, gearbox	2,44 €	2,90 €
V016B	43163	Air filter rubber for BMW R50, R50/2, R60 and R60/2, gearbox	2,44 €	2,90 €
V016C	43165	Air filter rubber for BMW R69 and R69S, gearbox	5,04 €	6,00 €
V017A	20016	Air filter rubber for BMW R50, R50/2, R60 and R60/2, aslant, carb to tube	3,82 €	4,55 €
V017B	21016	Air filter rubber for BMW R51/2-R67/3, straight, carburettor	3,82 €	4,55 €
V017C	43162	Air filter rubber for BMW R68, R69 and R69S, carburettor	3,36 €	4,00 €
V019	36968	Screw for gripper clamp carburettor for BMW R26, R27, R50/5, R60/5, R60/6 and R60/7	1,93 €	2,30 €
V019	039247	Screw for carburettor gripper clamp for BMW R26 und R27, M 6 ONLY for old clamp ring!!!	1,77 €	2,11 €
V019A	00174	Clamp air filter rubber for BMW R26-R27, R51/3-R67/3 and R50-R50/2 to clip, stainless steel, chromed	4,37 €	5,20 €
V019B	00176	Clamp air filter rubber for BMW R26-R27, R51/3-R67/3 and R50-R50/2 to screw, zincked, also for headpipe cover R50/5 and up	1,26 €	1,50 €
V019C	9000173	Clamp air filter rubber for BMW R25/3, R26 and R27 (clamp with screw)	1,51 €	1,80 €
V019F	039231	Gripper clamp, carburettor for BMW R26 and R27	4,12 €	4,90 €
V021	43166	Air filter rubber stop for BMW R68, R69 and R69S	0,63 €	0,75 €
V022	43133	Intake pipe for BMW R68, right side chrome-plated	77,23 €	91,90 €
V022	43132	Intake pipe for BMW R68, left side chrome-plated	77,23 €	91,90 €
V022	43178	Intake pipe for BMW R69 and R69S, left side chrome-plated	77,23 €	91,90 €
V022	43179	Intake pipe for BMW R69 and R69S, right side chrome-plated	77,23 €	91,90 €
V022	43174	Intake pipe for BMW R51/3 and R50-50/2, right or left side used – please advice which side and for which Typ of bike!!!	54,62 €	65,00 €
V023A	38049	Jet needle retaining spring for BMW R25/3-R27, R50/2, R60/2 and R69S (for needle with holes)	3,07 €	3,65 €
V023B	39176	Jet needle retaining spring for BMW R25, R51/2-R68 and R50-R69S (needle with slot)	0,63 €	0,75 €
V024A	39178	Throttle adjusting screw M 6, long for BMW R24-R25/3, R50-R69S and R50/5-R60/7	1,93 €	2,30 €
V024B	39180	Throttle adjusting screw M 6, short (carburettor) for BMW R24-R25/2 and R27	1,81 €	2,15 €
V024C	39113	Throttle adjusting screw M 5 for pipe elbow for BMW R26 and R27	2,23 €	2,65 €
V025	39182	Nut M 6 for throttle adjusting screw	0,46 €	0,55 €
V026	39184	Nut M 7 for mixture regulating screw and lock nut for elbow tube for BMW R24-R69S	0,50 €	0,60 €
V027	42112	Grommet for throttle cable on carburettor, small, traditionally for BMW R24-R27 (can be used on all other models)	1,56 €	1,86 €
V027	42111	Grommet for throttle cable on carburettor, large	1,51 €	1,80 €
V028A	42149	O-ring slide top for BMW R51/3-R69S	1,26 €	1,50 €
V029	42150	Gasket float top for BMW R24-R69S	0,84 €	1,00 €
V030A	19049	Mixture regulation screw for BMW R24, short	5,46 €	6,50 €
V030B	18049	Mixture regulation screw for BMW R25-R69S, long	6,64 €	7,90 €
V031	39183	Jacket for mixture regulating screw for BMW R24-R69S	2,10 €	2,50 €
V032	39185	Cap for mixture regulating screw for BMW R25/3-R27 and R51/3-R69S	2,02 €	2,40 €
V033A	17049	Needle jet #1208	14,12 €	16,80 €
V033B	17050	Needle jet #1308	14,12 €	16,80 €
V033C	17051	Needle jet #1408	14,12 €	16,80 €
V033D	17052	Needle jet #1708	14,12 €	16,80 €
V033E	17053	Needle jet #2108	14,12 €	16,80 €
V033F	039134	Jet holder for BMW R24, 1/22/27 carburettor	10,23 €	12,17 €
V034	39197	Locking screw for needle jet for BMW R25, R25/2, R26, R27 and R51/2-R69S	6,30 €	7,50 €
V034	39199	Locking screw for needle jet for BMW R25/3	2,77 €	3,30 €
V034D	39192	Carburettor strainer screw for fuel inlet for BMW R24-R27 WITHOUT strainer	7,14 €	8,50 €
V035	42130	Gasket ring for jets cover screw for all BMW models EXCEPT for BMW R24	0,42 €	0,50 €
V035B	42116	Gasket ring jet holder for BMW R24	0,49 €	0,58 €
V036	39120	Idle jet #50, slotted	4,96 €	5,90 €
V036	39117	Idle jet #35, slotted	4,96 €	5,90 €
V036	39119	Idle jet #45, slotted	4,96 €	5,90 €
V036	39118	Idle jet #40, slotted	4,96 €	5,90 €



V036	39121	Idle jet #55, slotted	4,96 €	5,90 €
V037A	39527	Slide adjusting screw for BMW R25/3 and R50-R69S	2,77 €	3,30 €
V037B	39282	Slide adjusting screw for BMW R26 and R27	3,45 €	4,11 €
V037C	39527	Slide adjusting screw for BMW R25/3 and R50-R69S	2,77 €	3,30 €
V038	39196	Locking screw for idle jet for BMW R25-R27	3,61 €	4,30 €
V039A	39170	Spring slide adjusting screw for BMW R25, R25/2, R25/3 and R51/3	1,30 €	1,55 €
V039B	39171	Spring slide adjusting screw for BMW R26, R27 and R51/3-R69S	0,84 €	1,00 €
V040	39311	Carburetor slide cover R25, R25/2, R25/3, R51/2-R67/3	20,97 €	24,95 €
V040B	39108	Carburettor slide cover tube for BMW R25/3 and R51/3-R69S	12,52 €	14,90 €
V040C	39223	Carburettor slide cover for BMW R26 and R27 (nose must be removed)	14,33 €	17,05 €
V040D	39179	Carburettor slide cover tube for BMW R26 and R27, complete	13,61 €	16,20 €
V041A	13049	Carburettor slide cover nut for BMW R25, R25/2 and R25/3	16,39 €	19,50 €
V041C	14049	Carburettor slide cover nut for BMW R50/2-R69S and R50/5-R60/7 big version, USED	25,88 €	30,80 €
V042	2049	Carburettor slide for BMW R25, R25/2, R51/2 and R67/3 Ø 22mm and Ø 24mm carburettors, old version	41,89 €	49,85 €
V042	3049	Carburettor slide for BMW R25/3, R51/3-R67/3 und R50-R60/2 Ø 24mm carburettors, (slider Ø 27mm)	41,89 €	49,85 €
V042	5049	Carburettor slide for BMW R51/3-R69S new version, (Ø 30mm)	37,98 €	45,20 €
V042	4049	Carburator slide for BMW R26 and R27	25,63 €	30,50 €
V043	42126	Gasket ring for idle jet lock screw for BMW R25-R69S	0,55 €	0,65 €
V044	32299	Carburettor cover screw for BMW R26 and R27, small with lateral drilling	3,36 €	4,00 €
V044A	39195	Carburator cover nut for BMW R51/3-R69S 24mm	9,16 €	10,90 €
V044B	39198	Carburator nut for BMW R25 and R51/3-R69 old fits for Ø 22mm carburettors, 16mm	6,64 €	7,90 €
V045A	42134	Gasket ring cover screw (Ø=16mm) for BMW R25 (Ø 22 carburettor) and R51/3-R69S, old	0,55 €	0,65 €
V045B	42135	Gasket ring cover screw (Ø=24mm) for BMW R51/3-R69S for 24Ø and 26Ø BING carburator	0,55 €	0,65 €
V046A	8049	Float 7 gram for BMW R27-R69S	51,93 €	61,80 €
V046B	9049	Float 11 gram for BMW R24-R26	37,77 €	44,95 €
V047A	52178	Float guide for BMW R50-R69S, "new" version	1,89 €	2,25 €
V047B	15049	Float needle for BMW R24-R27	6,22 €	7,40 €
V047C	16049	Float needle for BMW R51-R69S "old" (centre inlet)	6,64 €	7,90 €
V047D	51397	Float needle valve for BMW R50-R69S "new style" (offset inlet)	7,65 €	9,10 €
V047DA	52179	Washer float valve for BMW R51/2-R69S NEW	3,28 €	3,90 €
V048	52177	Carburettor tickler for BMW R51/3-R69S, 18mm new version	3,95 €	4,70 €
V048	39161	Carburettor tickler for BMW R24-R27	6,05 €	7,20 €
V048	39260	Carburettor tickler for BMW R51/2-R69S old version	5,00 €	5,95 €
V048	54911	Carburettor tickler for BMW R50/5, R60/5 and R60/6 until year of manufacture 1974	5,63 €	6,70 €
V049	39164	Spring for carburettor tickler for BMW R25-R69S	0,59 €	0,70 €
V049	54912	Spring for carburettor tickler for BMW R50/5, R60/5 and R60/6 until year of manufacture 1974	0,55 €	0,65 €
V050	39165	Pin for carburettor tickler for BMW R25-R69S	0,46 €	0,55 €
V051	39262	Washer for carburettor tickler for BMW R25-R69S	0,38 €	0,45 €
V052	39156	Screw for float cover for BMW R25-R69S	5,38 €	6,40 €
V053	52176	Float cover for BMW R25-R27, complete for BING-carburettor	18,48 €	21,99 €
V053	51395	Valve lever float cover for BMW R51/2-R69S new version with side outlet	1,47 €	1,75 €
V053	2052176	Float cover for BMW R25-R27, complete for BLITZ-carburettor	18,48 €	21,99 €
V053B	11049	Float cover for BMW R51/2-R69S, complete for BING-carburettor, old type	21,84 €	25,99 €
V053C	12049	Float cover for BMW R51/2-R69S, complete for BING-carburettor, new version with side valve	71,51 €	85,10 €
V053E	51396	Float valve lever axle "new" version for lateral outlet	1,22 €	1,45 €
V054A	7049	Carburettor slide spring for BMW R25-R25/3, R51/3 and R67 for Ø 22mm carburettor	1,01 €	1,20 €
V054B	6049	Carburettor slide spring for BMW R26 and R27	0,97 €	1,15 €
V054C	39168	Carburettor slide spring for BMW R51/3-R67/3 and R50-R60/2 for Ø 24mm carburettor	1,09 €	1,30 €
V054CC	0039169	Carburettor slide spring for BMW R68, R69 and R69S for Ø 26mm carburettor	1,09 €	1,30 €
V055	39193	Lock washer for float-chamber screw for BMW R24-R69S	0,25 €	0,30 €
V056	23049	Jet needle for BMW R25/3 (Ø 24 BING-carburettor)	13,19 €	15,70 €
V056A	24049	Jet needle for BMW R25, R25/2, R51/2 and R51/3 (Ø 22 carburettor)	7,14 €	8,50 €
V056C	22049	Jet needle for BMW R26, R27, R51/3-R67 and R50-R60/2 1/24/.. and 1/26/.. carburators	13,78 €	16,40 €
V056D	39049	Jet needle for BMW R69S "new system"	13,36 €	15,90 €
V056E	39274	Jet needle for BMW R50S, R68, R69 and R69S "old system"	5,21 €	6,20 €
V056F	39174	Jet needle for BMW R67/2 and R67/3 (Ø 24 carburettor)	2,86 €	3,40 €
V057	39004	BLITZ-Carburettor for BMW R25 and R25/2 conversion-kit complete	190,50 €	226,70 €
V057	30049	BLITZ-Carburettor for BMW R25/3 conversion-kit complete	190,50 €	226,70 €
V057	28049	BLITZ-Carburettor for BMW R26 and R27 conversion-kit complete	190,50 €	226,70 €



V057	26049	Carburettor for BMW R50 and R50/2, left side 1/24/149, also as replacement for BMW R60 and R60/2	545,38 €	649,00 €
V057	29049	Carburettor for BMW R51/2-R67/3, left side 1/24/159	545,38 €	649,00 €
V057	27049	Carburettor for BMW R50S and R69S, left side 1/26/91	545,38 €	649,00 €
V057	3004999	Carburettor for BMW R25/3 NEW, BING-style	294,12 €	350,00 €
V058A	39249	Main jet, hexagon, # 180	5,21 €	6,20 €
V058A	39250	Main jet, hexagon, # 185	5,21 €	6,20 €
V058A	39252	Main jet, hexagon, # 190	5,21 €	6,20 €
V058A	13176	Main jet, hexagon, #176	5,21 €	6,20 €
V058A	13178	Main jet, hexagon, # 178	5,21 €	6,20 €
V058A	39232	Main jet, hexagon, # 95	5,21 €	6,20 €
V058A	39233	Main jet, hexagon, # 100	5,21 €	6,20 €
V058A	39234	Main jet, hexagon, # 105	5,21 €	6,20 €
V058A	39235	Main jet, hexagon, #110	5,21 €	6,20 €
V058A	39236	Main jet, hexagon, # 115	5,21 €	6,20 €
V058A	39237	Main jet, hexagon, # 120	5,21 €	6,20 €
V058A	39238	Main jet, hexagon, # 125	5,21 €	6,20 €
V058A	39239	Main jet, hexagon, # 130	5,21 €	6,20 €
V058A	39240	Main jet, hexagon, # 135	5,21 €	6,20 €
V058A	39241	Main jet, hexagon, # 140	5,21 €	6,20 €
V058A	39242	Main jet, hexagon, # 145	5,21 €	6,20 €
V058A	39243	Main jet, hexagon, # 150	5,21 €	6,20 €
V058A	39244	Main jet, hexagon, # 155	5,21 €	6,20 €
V058A	39245	Main jet, hexagon, # 160	5,21 €	6,20 €
V058A	39248	Main jet, hexagon, # 175	5,21 €	6,20 €
V058A	39247	Main jet, hexagon, # 170	5,21 €	6,20 €
V058A	39246	Main jet, hexagon, # 165	5,21 €	6,20 €
V058A	39231	Main jet, hexagon, # 90	5,21 €	6,20 €
V058B	39131	Main jet, slotted, # 90	4,16 €	4,95 €
V058B	39132	Main jet, slotted, # 95	4,16 €	4,95 €
V058B	39133	Main jet, slotted, # 100	4,16 €	4,95 €
V058B	39134	Main jet, slotted, # 105	4,16 €	4,95 €
V058B	39135	Main jet, slotted, # 110	4,16 €	4,95 €
V058B	39136	Main jet, slotted, # 115	4,16 €	4,95 €
V058B	39137	Main jet, slotted, # 120	4,16 €	4,95 €
V058B	39138	Main jet, slotted, # 125	4,16 €	4,95 €
V058B	39139	Main jet, slotted, # 130	4,16 €	4,95 €
V058B	39140	Main jet, slotted, # 135	4,16 €	4,95 €
V058B	39141	Main jet, slotted, # 140	4,16 €	4,95 €
V058B	39142	Main jet, slotted, # 145	4,16 €	4,95 €
V058B	39143	Main jet, slotted, # 150	4,16 €	4,95 €
V058B	39144	Main jet, slotted, # 155	4,16 €	4,95 €
V058B	39145	Main jet, slotted, # 160	4,16 €	4,95 €
V058C	039144	Main jet for BMW R24, # 105, long	7,14 €	8,50 €
V058C	039142	Main jet for BMW R24, # 95, long	7,14 €	8,50 €
V058C	039143	Main jet for BMW R24, # 100, long	7,14 €	8,50 €
V058C	039145	Main jet for BMW R24, # 110, long	7,14 €	8,50 €
V059	43168	Centering bushing carburettor for BMW R69S	4,12 €	4,90 €
V059	42146	Flange gasket Carburator for BMW R25-R25/3 and R51/2-R60/2, Ø=24mm	4,41 €	5,25 €
V059	9942146	Flange gasket carburettor for BMW R25, R25/2 and R25/3 for BLITZ-Carburator, Ø=26,5mm	4,41 €	5,25 €
V059B	9032	Flange gasket Carburator for BMW R26 and R27	4,41 €	5,25 €
V059C	42147	Flange gasket Carburator for BMW R50S, R68, R69 and R69S, Ø=28mm	4,41 €	5,25 €
V061	39104	Carburettor flange for BMW R26 and R27, short for replacement carburettor	19,75 €	23,50 €
V061	39103	Carburettor flange for BMW R26 and R27, long	19,24 €	22,90 €
V062B	32032	Air filter housing for BMW R26 and R27 used	109,16 €	129,90 €
V100A	1049	Air filter for BMW R24, R25 and 25/2, metal case with air slider	60,50 €	72,00 €
V100A	3404999	Air filter housing for BMW R25/3, big version NEW	60,50 €	72,00 €
V100B	34049	Air filter for BMW R25/3, modern filter technic black	18,49 €	22,00 €
V10a	43147	Air filter screw for BMW R27, long for dry-type air filter-Deckel, stainless steel	17,73 €	21,10 €
V200B	43108	Air filter rubber for BMW R25/3	9,20 €	10,95 €
V202	35016	Protecting cap for carburettor for BMW R51/2-R69S	4,96 €	5,90 €
V203	90140	Wrench for carburettor for vehicle tool kit	5,01 €	5,96 €
V300A	39000	Gasket set for carburettor for BMW R25, R25/2 and R25/3 (bing carbs) ONLY for original BING carburettors	4,62 €	5,50 €
V300B	39003	Gasket set for carburettor for BMW R26 and R27	4,20 €	5,00 €
V300C	39005	Gasket set for Carburettor for BMW R51/2-R69S	3,36 €	4,00 €
V400	39284	Nut for carburettor clamp for BMW R26, R27 and R50/5-R75/5	0,42 €	0,50 €



V400	39190	Pivoting connection fuel hose for BMW R25/3-R27 crooked outflow, for original BING-carburettor	12,52 €	14,90 €
V400	39126	Mixing chamber insert #3 for BMW R24	22,69 €	27,00 €
V400	39127	Mixing chamber insert #5 for BMW R25 and R51/2-R68	22,69 €	27,00 €
V401	39191	Pivoting connection fuel hose for BMW R25/3, R26 and R27 crooked outflow, used	3,28 €	3,90 €
V999	0006912	Screw for BLITZ-carburettor, M8 x 20, Allen® key, flat	0,59 €	0,70 €
V999	0039291	Locking screw excelleration pump for BMW R27	10,84 €	12,90 €

Group Z: Sidecar spare parts

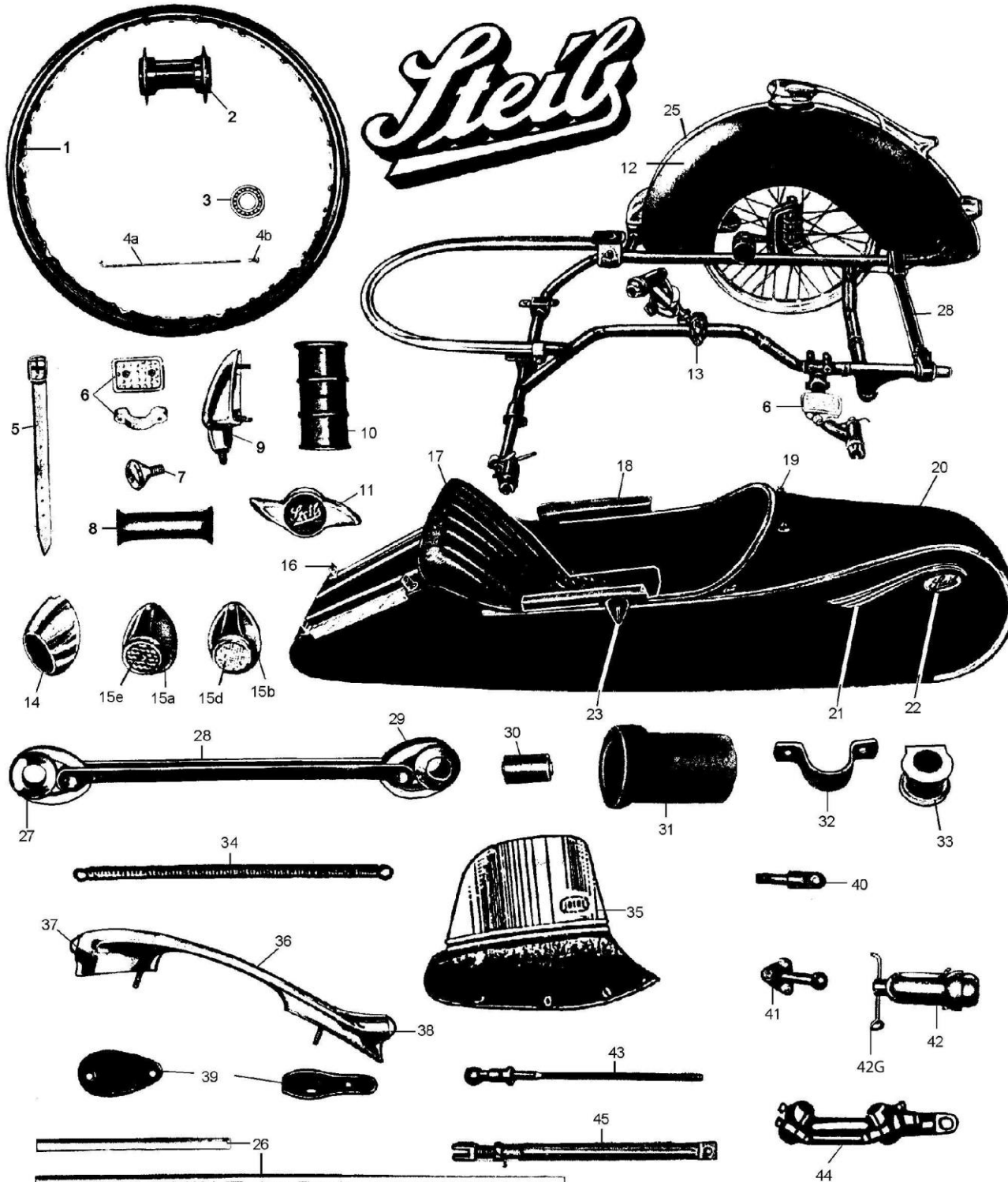

<u>Picture-No.</u>	<u>Article-No.</u>	<u>Description</u>	<u>Net</u>	<u>Gross</u>
Z000	9810219	Front bumper mount for sidecar STEIB LS200, left side steel, zink plated	56,22 €	66,90 €
Z000	9810213	Front bumper mount for sidecar STEIB LS200, right side aluminium	50,34 €	59,90 €
Z000	98480	Boat mounting cone for sidecar STEIB S350, "Original", 78mm, front drilling 13mm, aluminium conus	17,23 €	20,50 €
Z000	981121	Front bumper for sidecar STEIB LS200	79,92 €	95,10 €
Z000	60012	Carpet Set for STEIB LS200, 2 pieces legroom and trunk	44,12 €	52,50 €



Z000	9212311	Inner trim set for sidecar STEIB TR500, black with map pocket	83,95 €	99,90 €
Z000	19711	Eyebolt for sidecar connection for rubber inlay M18 x 1,5mm, length 250mm	43,49 €	51,75 €
Z000	9020217	Sub-frame for side car for BMW R50/5-R100/7 with connecting clamps and connecting rods	671,43 €	799,00 €
Z000	2200206	Swingarm for STEIB TR500 torque rod with torsional spring	180,00 €	214,20 €
Z000	9212360	Inner trim set for sidecar STEIB LS200, black with map pocket	83,95 €	99,90 €
Z000	9260018	Inner trim set for sidecar STEIB S350, red with map pocket	83,95 €	99,90 €
Z000	9260019	Inner trim set for sidecar STEIB S500, black with map pocket	83,95 €	99,90 €
Z000	0981121	Front bumper for sidecar mudguard STEIB LS200-S500 stainless steel, polished	125,97 €	149,90 €
Z000	1022402	Mounting-Screw for hand grip STEIB TR500 stainless steel polished	3,99 €	4,75 €
Z000	6008001	Connection stray bullet type sidecar, diameter 32mm, length 270mm	88,23 €	104,99 €
Z000	6008002	Connection stray bullet type sidecar, diameter 24mm, length 270mm	67,14 €	79,90 €
Z000	9260012	Carpet Set for STEIB S300/S500, 2 pieces legroom and trunk	44,12 €	52,50 €
Z000	9212312	Inner trim set for sidecar STEIB TR500, red with map pocket	83,95 €	99,90 €
Z000	0112005	Hinge/Bolt for boot lid TR500, Steib	22,44 €	26,70 €
Z000	9260017	Inner trim set for sidecar STEIB S500, red with map pocket	83,95 €	99,90 €
Z000	9260016	Inner trim set for sidecar STEIB S350, black with map pocket	83,95 €	99,90 €
Z001	6071	Rim for sidecar, size 1.85x19, 40 holes, chrome (made in Germany)	129,33 €	153,90 €
Z001a	400236	Side car wheel 19" with chrom rim	344,45 €	409,90 €
Z001b	400237	Side car wheel 18" with chrom rim	344,45 €	409,90 €
Z002B	99800	Wheel hub for sidecar for M 4 spokes	142,02 €	169,00 €
Z003	110641	Wheel bearing for sidecar, both-sided sealed	9,20 €	10,95 €
Z004	038105	Spoke 18" side car, M3,5 x 200 with nippel	1,60 €	1,90 €
Z004A	7044	Spoke for BMW R51/2-R68, M4 x 210, half hub, long chromed, with nippel, also for side car	1,01 €	1,20 €
Z004B	30070	Spoke nipple M4	0,34 €	0,40 €
Z004Bb	0030070	Spoke nipple M4 stainless steel	0,42 €	0,50 €
Z004C	131019	Spoke 19" side car, M3,5 x 212 chromed, with nippel	1,85 €	2,20 €
Z005	1043	Leather belt for side car mount	6,22 €	7,40 €
Z006A	400133	Step board for STEIB sidecar, complete with clamps and screws	37,14 €	44,20 €
Z006B	400134	Step board rubber for STEIB sidecar - ONLY for LS200	19,24 €	22,90 €
Z007	101144	Conical screw for STEIB sidecar fender aluminium	28,15 €	33,50 €
Z008	910216	Fender-holder for sidecar STEIB LS200, rear inside thread, replacement for repair	34,40 €	40,94 €
Z008	200123	Distance pipe fender sidecar for STEIB LS200-S500 narrow version	26,81 €	31,90 €
Z008a	0200123	Distance pipe fender sidecar for STEIB TR500 wide version	20,13 €	23,95 €
Z009	10214	Fender-holder for sidecar STEIB LS200, S350, S500 and TR500, front aluminium polished	58,74 €	69,90 €
Z009A	910215	Counterpart for Front Fender-holder for sidecar STEIB LS200-S500 for welding to the frame	49,54 €	58,95 €
Z009B	12155	Rubber pad for fender holder side car	9,66 €	11,50 €
Z010A	20097	Wheel suspension rubber for STEIB LS200-S500	31,85 €	37,90 €
Z011A	10237	Wing nut for STEIB side car, M18, small	16,36 €	19,47 €
Z011B	10348	Wing nut "Steib", M18, big	31,75 €	37,78 €
Z011E	17044	Wing nut for STEIB side car, M20x1,5 Aluminium	21,60 €	25,70 €
Z012	4002661	Fender for sidecar STEIB LS200-TR500, complete incl. Cobra-light, tail light and trim, glass-fibre reinforced plastic	357,90 €	425,90 €
Z012A	200122	Fender for sidecar STEIB LS200-TR500 slim, tin, ground coat, without mounting parts	235,21 €	279,90 €
Z012C	400266	Fender for sidecar STEIB LS200-TR500 glass-fibre reinforced plastic	146,18 €	173,95 €
Z012D	2001221	Fender for sidecar STEIB TR500 ground coat, tin, 18cm wide	243,61 €	289,90 €
Z013A	20053	Clamp for sidecar connecting rod, complete	62,94 €	74,90 €
Z013B	20015	Rubber insert for side car strut	6,64 €	7,90 €
Z014A	400246	Rear reflector sidecar (cat's eye), aluminium original shape	42,69 €	50,80 €
Z014B	623020	Rear reflector, red, universal round, Ø circa 67mm	2,94 €	3,50 €
Z014B	9400247	Rubber pad for aluminium reflector side car	10,00 €	11,90 €
Z014C	400247	Rear reflector insert (cat's eye) for aluminium housing of STEIB sidecar	8,32 €	9,90 €
Z015	19004	Lens for "Eber" tail light, white, with aluminium ring	16,72 €	19,90 €
Z015	190051	Lens for sidecar position light „Eber“-light, red	9,66 €	11,50 €
Z015A	2030	Taillight Eber-shape for BMW R25, R25/2, R51/2 and R67 with brakelight red and pad (only one lens), black	74,37 €	88,50 €
Z015B	2033	Front-light Eber-shape for sidecar white lens	76,72 €	91,30 €
Z015BB	02033	Taillight Eber-shape for sidecar, rear red lens	76,72 €	91,30 €
Z015C	2003	Rubber pad for Eber-taillight for BMW R25-R25/3 and R51/2-R68	4,03 €	4,80 €
Z016	925006	Trim strip Set for sidecar STEIB LS200, luggage space	25,13 €	29,90 €
Z016	09270	Luggage eyelet for sidecar LS200 and S350 aluminium	15,04 €	17,90 €
Z016	9213216	Luggage bar for side car STEIB S350 polished aluminium	27,31 €	32,50 €
Z016a	9213215	Luggage bar for side car STEIB LS200 polished aluminium	27,65 €	32,90 €
Z017	60063	Seat for sidecar STEIB TR500 two-piece, spring core, red	226,39 €	269,40 €
Z017	06008	Seat for sidecar STEIB LS200 and S350 spring core, black	193,19 €	229,90 €



Z017	60064	Seat for sidecar STEIB TR500 two-piece, spring core, black	210,00 €	249,90 €
Z017A	09700	Seat for sidecar STEIB LS200 and S350 foam material, red	159,58 €	189,90 €
Z017A	06007	Seat for sidecar STEIB LS200 and S350 foam material, black	159,58 €	189,90 €
Z018A	40082	Armrest for sidecar short, red LS200	14,12 €	16,80 €
Z018A	40080	Armrest for sidecar short, black LS200	14,71 €	17,50 €
Z018Ab	40180	Armrest for sidecar medium, black TR500	13,36 €	15,90 €
Z018Ab	40182	Armrest for sidecar medium, red TR500	13,36 €	15,90 €
Z018B	40083	Armrest for sidecar long, red S350/S500	14,71 €	17,50 €
Z018B	40081	Armrest for sidecar long, black S350/S500	14,71 €	17,50 €
Z019	10337	Side car dust cover mounting nail for STEIB LS200-S500	4,12 €	4,90 €
Z019B	2057	High twister-mount for sidecar dust cover	2,27 €	2,70 €
Z019C	2059	Eyelet for sidecar cover, oval, 2-parts	1,26 €	1,50 €
Z019D	2053	Eyelet for sidecar cover, round, 2-parts	0,84 €	1,00 €
Z021	200125	Trim eyebrow shape for STEIB LS200 Aluminium	29,33 €	34,90 €
Z022	10351	Emblem rubber for STEIB S350 & S500, front	4,03 €	4,80 €
Z022A	200124	Emblem "STEIB" LS200, oval-shape, on the side, front	27,65 €	32,90 €
Z022B	1029	Emblem "STEIB" S350-500, Rosette, round-shape, front	23,49 €	27,95 €
Z022C	10231	Emblem STEIB LS200, TR500, round, on the side, front	23,53 €	28,00 €
Z023	400302	Wind shield angle bracket for STEIB LS200-S500 stainless steel	16,72 €	19,90 €
Z024	200226	Trim strip Set for STEIB LS200 "bishop's crozier" "wave"-shape	61,01 €	72,60 €
Z025	13211	Trim strip for sidecar, 2m Aluminum	22,65 €	26,95 €
Z025	13210	Trim strip Set sidecar, fender when using the "cobra" light	25,63 €	30,50 €
Z026	1311041	Trim strip screw for sidecar small head, 12mm	1,01 €	1,20 €
Z026	200210	Trim strip Set for STEIB (S350), S500 and S501 incl. trim strip for fender	147,06 €	175,00 €
Z026	131104	Trim strip screw for STEIB sidecar flat wide head, 12mm	1,64 €	1,95 €
Z027	10345	Boat holder rubber for sidecar STEIB LS200 and TR500, rear, small	12,52 €	14,90 €
Z028A	121179	Traverse for sidecar STEIB LS200	25,13 €	29,90 €
Z028B	121180	Traverse for sidecar STEIB TR500	25,17 €	29,95 €
Z029	38016	Boat holder rubber ring for sidecar STEIB LS200 and TR500, rear	21,51 €	25,60 €
Z030	10350	Rubber boat-holder for sidecar STEIB S350 and S500, front 14mm inside	7,14 €	8,50 €
Z030	10349	Rubber boat-holder for sidecar STEIB S350 and S500, rear 12mm inside	6,72 €	8,00 €
Z030	10346	Metal boot, sidecar crossbar for STEIB LS200 and TR500	7,98 €	9,50 €
Z031	10332	Boat holder rubber for sidecar STEIB TR500, front	19,75 €	23,50 €
Z032A	12129	Clamp sidecar mount for STEIB LS200, front	19,75 €	23,50 €
Z032B	121102	Clamp sidecar mount for STEIB TR500, front	29,33 €	34,90 €
Z033A	10311	Boat holder rubber for sidecar STEIB LS200, front	15,63 €	18,60 €
Z033B	43044	Boat holder rubber for sidecar STEIB S250, front (swivel rubber)	83,19 €	99,00 €
Z034	1412	Seat spring for STEIB LS200, short	8,82 €	10,50 €
Z034A	14121	Seat spring for STEIB LS350 and S500, long	7,14 €	8,50 €
Z035	3059	Windshield for STEIB LS200-S500 complete with mounting parts and planket	185,63 €	220,90 €
Z035	88901	Windshield set TR500, original shape complete with stainless steel holders, blanket and mounting parts	214,20 €	254,90 €
Z036	400140	Handle light STEIB side car "Kobra" complete with white/red lens and rubber pad	167,98 €	199,90 €
Z037	10324	Handle light side car "Kobra", white lense for side car	9,66 €	11,50 €
Z037A	0010326	Handle light side car "Kobra", orange lense, front for side cars as turn signal lense	12,02 €	14,30 €
Z037B	0010327	Handle light side car "Kobra", orange lense, rear for side cars as turn signal lense	12,02 €	14,30 €
Z038A	10325	Handle light side car "Kobra", red lense with STEIB lettering	10,17 €	12,10 €
Z038B	10326	Bulb holder for Cobra-Light	5,38 €	6,40 €
Z039	10327	Rubber pad set for "Kobra" side car lamp, front and rear, for side cars	19,24 €	22,90 €
Z040A	1062	Sidecar connecting bolt, flat, 12mm for BMW R51/3-R68	15,88 €	18,90 €
Z040B	14044	Sidecar connecting bolt, flat, 13mm for BMW R50-R69S	12,94 €	15,40 €
Z040C	14045	Ballpin 12mm for sidecar connection	15,88 €	18,90 €
Z040D	14046	Ballpin 13mm for sidecar connection	15,88 €	18,90 €
Z041A	400162	Side car ball mount 3.point for BMW R25-R27	29,33 €	34,90 €
Z041B	15045	Connection for sidecar, 3.point, eyebolt R25-R27	48,07 €	57,20 €
Z042A	40010	Weld-on bell, sidecar connection (without split pin / picot bolt)	74,12 €	88,20 €
Z042B	99900	Weld-on ball for sidecar mount, for 1 Zylinder-frame	23,95 €	28,50 €
Z042C	14047	Ballpin for BMW R25 for sidecar connection, screw-in frame lower bottom	15,04 €	17,90 €
Z042C	99901	Weld-on ball for sidecar mount R51/2-R69S	16,38 €	19,49 €
Z042D	40011	Split pin for sidecar weld-on bell	1,01 €	1,20 €
Z042F	99903	Inner clamp for sidecar connecting bell	16,72 €	19,90 €
Z042G	99905	Pin for sidecar weld-on bell, straight	8,32 €	9,90 €
Z042H	99906	Inner clamb-nut for sidecar connecting bell	8,82 €	10,50 €
Z043A	151113	Engine axle with ball-headed pin and nut for BMW R51/3-R69S for side car use	37,73 €	44,90 €
Z043B	151114	Engine axle with ball-headed pin for BMW R51/3-R69S for side car use, stainless steel	61,26 €	72,90 €
Z044	60084	Sidecar connection R25, front/upper w/ball	55,95 €	66,58 €



Z044A	60083	Sidecar connection for BMW R25/2 and R25/3, front/upper with eyebolt	92,35 €	109,90 €
Z044B	60082	Sidecar connection for BMW R26 and R27, front/upper with eyebolt	75,55 €	89,90 €
Z044D	60085	Sidecar connection for BMW R26 and R27, front/upper with ball	71,43 €	85,00 €
Z045	9230056	Bushing sidecar connecting rod, 30cm, without mounting parts	33,61 €	40,00 €
Z045	9235055	Bushing sidecar connecting rod, 35cm, without mounting parts	39,41 €	46,90 €
Z045A	12195	Strut (eye) for sidecar mount rear/top	113,70 €	135,30 €
Z045B	12196	Sidecar connecting rod side car STEIB TR500 for BMW R50-R69S top front and rear	67,14 €	79,90 €
Z045C	12193	Strut (eye) for sidecar mount front/top	110,84 €	131,90 €
Z045D	12194	Sidecar connecting rod 45° , w/bell for ball and clamp	155,38 €	184,90 €
Z045E	12197	Nut M18 x 1,5 flat, for sidecar connecting rod zincked	1,43 €	1,70 €
Z045F	9211154	Bushing sidecar connecting rod, 25cm, with 15cm thread rod without clamps	46,22 €	55,00 €
Z045G	9211155	Bushing sidecar connecting rod, 35cm, with 15cm thread rod without clamps	50,34 €	59,90 €
Z045H	9211156	Bushing sidecar connecting rod, 30cm, with 15cm thread rod without clamps	50,34 €	59,90 €
Z045i	9225054	Bushing sidecar connecting rod, 25cm, without mounting parts	33,61 €	40,00 €
Z075	20075	Trunk snap for side car STEIB TR500 with lock	113,36 €	134,90 €
Z076	20076	Trunk snap for side car STEIB TR500 without lock	111,68 €	132,90 €
Z080	10341	Side car dust cover for STEIB S250 with eyelets (premium quality)	86,47 €	102,90 €
Z080	10340	Side car dust cover for STEIB LS200 with eyelets (premium quality)	109,24 €	130,00 €
Z080	10336	Side car dust cover for STEIB LS200, S350 and S500 black	104,03 €	123,80 €
Z081	10347	Side car dust cover for STEIB S350 and S501 with eyelets (premium quality)	86,47 €	102,90 €
Z082	10591	Side car dust cover for STEIB TR500 with eyelets (premium quality)	126,05 €	150,00 €
Z084	3037	Identification plate for STEIB sidecar	6,18 €	7,35 €
Z085	40098	T-grip trunk for STEIB S500 lockable	62,39 €	74,24 €
Z085	4009801	T-grip lock-snap for STEIB S500	16,09 €	19,15 €
Z086	400298	Light for sidecar, universal red/white - REMNANTS	12,52 €	14,90 €
Z086	4009800	T-grip rubber support for STEIB S500	4,62 €	5,50 €
Z087	4001	Spare parts catalogue for STEIB sidecars in GERMANY	25,23 €	27,00 €
Z088	20045	Sub-frame for side car for BMW R26	134,37 €	159,90 €
Z088	20044	Sub-frame for side car for BMW R27	151,18 €	179,90 €
Z090	10328	Bulb holder universal with angle, socket BA15S	4,16 €	4,95 €
Z091	20068	Holding plate for seat spring for STEIB LS200, S350 and S500, front to weld on	25,13 €	29,90 €
Z091	20069	Holding plate for seat spring for STEIB S350 and S500, rear to weld on	20,13 €	23,95 €
Z093	227201	Indicator light for sidecar, fender mount	14,54 €	17,30 €
Z232	41400	Spring, boat-holder S 350	127,06 €	151,20 €
Z999	60020	Luggage rack for side car STEIB S500 and S501	294,03 €	349,90 €
Z999	10224	Hand grip for sidecar STEIB TR500, polished aluminium	41,01 €	48,80 €
Z999	03059	Windshield mounting set for STEIB LS200-S500 complete	25,13 €	29,90 €
Z999	95059	Wind shield bracket set for STEIB LS200-S500 steel, cined	20,59 €	24,50 €
Z999	0400272	Clamping bell for spare wheel holder for STEIB TR500 with clamp bolt and butterfly nut with STEIB lettering	130,25 €	155,00 €

Group L: Literature, Manuals

<u>Article-No.</u>	<u>Description</u>	<u>Net</u>	<u>Gross</u>
998376	Total Power Grease, Innotec Spray-fat	13,61 €	16,20 €
27030	Repair manual for BMW R45/R65 until year of manufacture 09/1984 Model 82/83	51,40 €	55,00 €
992060	Gearoil SAE90 GL4	6,00 €	7,14 €
66100	Goggle frame set for Aviator T1/T2 chrome	30,25 €	36,00 €
66101	Goggleframe f. glasses Intepelle	29,37 €	34,95 €
999401	Test light, 6-24 Volt	8,49 €	10,10 €
6610004	Goggle frame set for Aviator T1/T2 gunmetal	30,25 €	36,00 €
0025485	Book: "Der Kupferwurm" and "Besser machen, Arbeiten an Motorrädern" in one Vol. , GERMAN LANGUAGE from Carl Hertweck, special Edition: 2. Edition 2006	37,29 €	39,90 €
3038028	Book: "BMW-Motorräder, Die Jahrhundert-Story", GERMAN LANGUAGE from Frank Rönicke, 1. Edition 2015	27,94 €	29,90 €
96165	List of models R32-R100RS, with data copy	1,82 €	1,95 €
10020	Booklet: Service and repair of the electrical system (GERMAN LANGUAGE) for BMW R24-R25/3 and R51/3-R69S, 6V and 12V	8,36 €	9,95 €
0100200	Booklet: Service and repair of the electrical system (GERMAN LANGUAGE) for BMW R25/2, R51/3, R67, R67/2 and R68, 6V	4,21 €	4,50 €
01558	Book: "BMW Motorräder seit 1923", GERMAN LANGUAGE from Wolfgang Zeyen and Jan Leek, 1.Edition 2004	46,64 €	49,90 €
09002	Booklet: Chart about BMW R25/2 and R51/3	7,10 €	7,60 €
70218	Spare parts catalogue for BMW R11 and R16 series 1/5 IN GERMAN	22,90 €	24,50 €
4012	Spare part catalogue for BMW R12 and R17 IN GERMAN	19,35 €	20,70 €
4006	Spare parts catalogue for BMW R20 and R23 IN GERMAN	17,90 €	19,15 €
9021	Spare parts catalogue for BMW R24 in GERMAN	15,79 €	16,90 €
9022	Spare parts catalogue for BMW R25 IN GERMAN	15,79 €	16,90 €
9023	Spare parts catalogue for BMW R25/2 in GERMAN	15,79 €	16,90 €
9024	Spare parts catalogue for BMW R25/3 in GERMAN	15,79 €	16,90 €



9025	Spare parts catalogue for BMW R26 and R27 in GERMAN	17,06 €	18,25 €
4004	Spare parts catalogue for BMW R35 in GERMAN	17,90 €	19,15 €
4008	Spare parts catalogue for BMW R5 and R6 in GERMAN	23,36 €	25,00 €
4026	Spare parts catalogue for BMW R50-R69S (German, English, French)	17,06 €	20,30 €
70219	Spare parts catalogue for BMW R51, R61, R66 and R71 IN GERMAN	23,36 €	25,00 €
9029	Spare parts catalogue for BMW R51/2 in GERMAN	15,79 €	16,90 €
9028	Spare parts catalogue for BMW R51/3-R67/3 IN GERMAN	15,79 €	16,90 €
4057	Spare parts catalogue for BMW R57 and R63 IN GERMAN	20,45 €	21,88 €
9020	Spare parts catalogue for BMW R68 in GERMAN	15,79 €	16,90 €
4003	Spare parts catalogue for BMW R75 Wehrmacht with side car IN GERMAN, REMNANTS	28,04 €	30,00 €
4001	Spare parts catalogue for STEIB sidecars in GERMAN	25,23 €	27,00 €
5025	Cleaner for stainless steel, 250ml spraybottle	12,56 €	14,95 €
1083	Polishing wadding Nevrr Dull	6,81 €	8,10 €
3080001	Autosol Chrom-Polish, 75ml tube	5,21 €	6,20 €
3020	Repair manual for BMW R25, R25/2 and R25/3, extension (GERMAN LANGUAGE)	8,65 €	9,25 €
2020	Repair manual for BMW R25 (GERMAN LANGUAGE)	17,99 €	19,25 €
37020	Repair manual for BMW R25 and R25/2 (ENGLISH LANGUAGE)	33,55 €	35,90 €
4020	Repair manual for BMW R26 and R27 (GERMAN LANGUAGE)	22,24 €	23,80 €
6020	Repair manual for BMW R50-R69S (GERMAN, ENGLISH, FRENCH, SPANISH-LANGUAGE)	23,11 €	27,50 €
5020	Repair manual for BMW R51/3, R67 and R67/2 (GERMAN LANGUAGE)	20,00 €	23,80 €
5021	Repair manual for BMW R67/2, R67/3 and R68, extension (GERMAN LANGUAGE)	8,65 €	9,25 €
10021	Repair manual for BMW R51/2 (GERMAN LANGUAGE)	22,24 €	23,80 €
70200	Owner's manual for BMW R11 and R16 (GERMAN LANGUAGE)	23,36 €	25,00 €
70216	Owner's manual for BMW R12 (GERMAN LANGUAGE)	20,47 €	21,90 €
70214	Owner's manual for BMW R20 (GERMAN LANGUAGE)	20,37 €	21,80 €
70215	Owner's manual for BMW R23 (GERMAN LANGUAGE)	20,37 €	21,80 €
70201	Owner's manual for BMW R24 (GERMAN LANGUAGE)	9,20 €	9,84 €
70202	Owner's manual for BMW R25 (GERMAN LANGUAGE)	9,20 €	9,84 €
70203	Owner's manual for BMW R25/2 (GERMAN LANGUAGE)	9,41 €	11,20 €
70204	Owner's manual for BMW R25/3 (GERMAN LANGUAGE)	12,52 €	14,90 €
70205	Owner's manual for BMW R26 (GERMAN LANGUAGE)	12,94 €	15,40 €
70206	Owner's manual for BMW R27 (GERMAN LANGUAGE)	13,95 €	16,60 €
7023	Owner's manual for BMW R35 (GERMAN LANGUAGE)	20,37 €	21,80 €
70217	Owner's manual for BMW R5 and R6 (GERMAN LANGUAGE)	20,47 €	21,90 €
70207	Owner's manual for BMW R50-R69 (GERMAN LANGUAGE)	12,56 €	13,44 €
702071	Owner's manual for BMW R50, R60 and R69S (GERMAN LANGUAGE)	20,37 €	21,80 €
70213	Owner's manual for BMW R51, R66, R61 and R71 (GERMAN LANGUAGE)	20,37 €	21,80 €
7024	Owner's manual for BMW R51/3-R68 (GERMAN LANGUAGE)	20,37 €	21,80 €
70208	Owner's manual for BMW R51/2 (GERMAN LANGUAGE)	12,56 €	13,44 €
7022	Owner's manual for BMW R75 (GERMAN LANGUAGE) Wehrmachtsskrd with side car, REMNANTS	20,45 €	21,88 €
70222	Owner's manual for BMW R12 and R17 - ENGLISH LANGUAGE REMNANTS!!!	15,37 €	16,45 €
27020	Owner's manual for BMW R25 - ENGLISH LANGUAGE	20,37 €	21,80 €
27022	Owner's manual for BMW R25/2 - ENGLISH LANGUAGE	20,37 €	21,80 €
27023	Owner's manual for BMW R25/3 - ENGLISH LANGUAGE	27,94 €	29,90 €
27021	Owner's manual for BMW R26 - IN THREE LANGUAGES English, French, Spanish	20,47 €	21,90 €
27027	Owner's manual for BMW R27 - IN THREE LANGUAGES English, French, Spanish	20,47 €	21,90 €
17020	Owner's manual for BMW R50-R69S, Earles fork models - IN THREE LANGUAGES English, French, Spanish	22,34 €	23,90 €
17021	Owner's manual for BMW R50-R69SUS, tele fork - ENGLISH LANGUAGE	18,60 €	19,90 €
70221	Owner's manual for BMW R51/2 - ENGLISH LANGUAGE	22,38 €	23,95 €
7025	Owner's manual for BMW R51/3-R67 - ENGLISH LANGUAGE	20,37 €	21,80 €
11020	Booklet - special tools - IN GERMAN LANGUAGE	4,58 €	4,90 €
0001660	Cleaning cloth vehicle tools for BMW motorcycles	5,00 €	5,95 €
1889102	Helmet half shell, fiberglass, black, M	50,38 €	59,95 €
1889105	Helmet half shell, fiberglass, black, XXL	50,38 €	59,95 €
1889122	Helmet half shell, fiberglass, black, chequered, M	67,14 €	79,90 €
1889203	Helmet Jet, ECE-22.05, black, M	58,78 €	69,95 €
1889213	Helmet Jet, ECE-22.05, white, M	58,78 €	69,95 €
1889216	Helmet Jet, ECE-22.05, white, XXL	58,78 €	69,95 €
1889246	Helmet Jet, ECE-22.05, ivory Classic, XXL	75,59 €	89,95 €
1889703	Helmet Jet, ECE-22.05, black, chequered, M black textile lining	83,95 €	99,90 €
1889156	Helmet half shell, fiberglass, "British Style", uni, unicolor white, real black leather, M, REMNANTS	66,39 €	79,00 €
1889164	Helmet half shell, fiberglass, "British Style", TT TwoTone black-silver, real black leather, XL, REMNANTS	66,39 €	79,00 €
1885715	Helmet half shell, fiberglass, ivory, S	58,78 €	69,95 €
1889103	Helmet half shell, fiberglass, black, L	50,38 €	59,95 €



1889104	Helmet half shell, fiberglass, black, XL	50,38 €	59,95 €
1885648	Helmet half shell, fiberglass, black, chequered, S	67,14 €	79,90 €
1889123	Helmet half shell, fiberglass, black, chequered, L	67,14 €	79,90 €
1885647	Helmet half shell, fiberglass, silver, S	58,78 €	69,95 €
1889144	Helmet half shell, fiberglass, silver, XL	58,78 €	69,95 €
1885645	Helmet half shell, fiberglass, white, S	58,78 €	69,95 €
1889114	Helmet half shell, fiberglass, white, XL	58,78 €	69,95 €
1889202	Helmet Jet, ECE-22.05, black, S	58,78 €	69,95 €
1889204	Helmet Jet, ECE-22.05, black, L	58,78 €	69,95 €
1889232	Helmet Jet, ECE-22.05, silver, S	58,78 €	69,95 €
1889214	Helmet Jet, ECE-22.05, white, L	58,78 €	69,95 €
1889215	Helmet Jet, ECE-22.05, white, XL	58,78 €	69,95 €
1889225	Helmet Jet, ECE-22.05, white, chrome-edge, XL black textile lining, REMNANT STOCK!	83,99 €	99,95 €
1889226	Helmet Jet, ECE-22.05, white, chrome-edge, XXL black textile lining, REMNANT STOCK!	83,99 €	99,95 €
24003	Helmet Jet, fiberglass, black/silver, no ECE, S extra small shell, brown leather lining	75,59 €	89,95 €
1889254	Helmet Jet, fiberglass, black/silver, no ECE, L extra small shell, brown leather lining	75,59 €	89,95 €
1889255	Helmet Jet, fiberglass, black/silver, no ECE, XL extra small shell, brown leather lining	75,59 €	89,95 €
1889265	Helmet Jet, fiberglass, green/silver, no ECE, XL extra small shell, brown leather lining	75,59 €	89,95 €
1889702	Helmet Jet, ECE-22.05, black, chequered, S black textile lining	83,95 €	99,90 €
60327	Goggle-Classic for half-shell helmet, chrome frame, black	33,53 €	39,90 €
04114	Goggle Aviator Retro, natural rubber chrome	110,00 €	130,90 €
0411401	Goggle Aviator Retro, natural rubber gunmetal	110,00 €	130,90 €
67062	Goggle Aviator Retro, leather chrome	121,85 €	145,00 €
04119	Goggle Aviator Retro optical chrome, for spectacle wearer	172,27 €	205,00 €
068002	Goggle Aviator Vintage, leather chrome	142,02 €	169,00 €
068001	Goggle Aviator Vintage, leather gunmetal	142,02 €	169,00 €
0670732	Goggle Aviator/Jeanted T2 (clear) Retro Pilot also for spectacle wearer	130,25 €	155,00 €
0670735	Goggle Aviator/Jeanted T2 tinted glasses also for spectacle wearer, chrom frame	130,25 €	155,00 €
0670736	Goggle Aviator/Jeanted T2 mirrored-glass also for spectacle wearer, chrom frame	134,37 €	159,90 €
0501501	Goggle Cilmax 501, leather chrome	56,81 €	67,60 €
4182778	Goggle Aviator/Jeanted T2 brown leather, brown glasses also for spectacle wearer, golden frame	134,37 €	159,90 €
4600210	Goggle alternate strap Aviator Retro	20,97 €	24,95 €
61250	Google alternate strap T1/T2	26,89 €	32,00 €
04116	Goggle Aviator Spare glasses set, yellow	13,36 €	15,90 €
0004116	Goggle Aviator Retro Spare glasses Set, clear	14,20 €	16,90 €
1004116	Goggle Aviator Retro Spare glasses set, smoke	13,36 €	15,90 €
067173	Goggle Jeanted T1/2 Spare glasses set, yellow	21,01 €	25,00 €
0067174	Google Jeanted T1/2 Spare glasses Set, tinted glass	21,01 €	25,00 €
067172	Goggle Jeanted T1/2 Spare glasses set, clear	21,01 €	25,00 €
067175	Goggle Jeanted T1/2 Spare glasses set, mirrored-glass	33,53 €	39,90 €
0005317	Tool set for BMW R24-R69S 19 pieces, original BMW	184,79 €	219,90 €
30752	Tool bag, 19cm high WITHOUT CONTENT	10,84 €	12,90 €
3075217	Tool bag, 17cm high WITHOUT CONTENT	10,84 €	12,90 €
3075215	Tool bag, 15cm high WITHOUT CONTENT	10,84 €	12,90 €
13070	Varnish pen, black, 086	14,20 €	16,90 €
022001	Rust remover "Tankcure"	15,08 €	17,95 €
2233444	Rust remover "FERTAN", 250ml No shipment outside the European Union possible!	15,55 €	18,50 €
24000	Fuel tank seal mastic "Tankcure", 450g for one fuel tank ! (up to 24L tank)	28,49 €	33,90 €
7131139	Rider's mask, black, cotton	4,20 €	5,00 €



In order to accomplish a fast dispatch, we ask you to give to us your credit card details

Please fill out this side and **fax it to us at +49 69 23 38 40**

Credit card direct debit authorisation

Hereby I authorize

Ulis Motorradladen GmbH
Gutleutstrasse 144
D-60327 Frankfurt am Main

to deduct invoice amounts of my credit card account.

Name _____

Customer's number (if known) _____

Street _____

ZIP / Town / State / Country _____

Name of Account owner _____

Name of the bank _____

Credit card number _____

Date of expiration _____

CV Code (three digits on the back of your card in the signature area) _____

Date / Signature _____



How to find Ulis Motorradladen

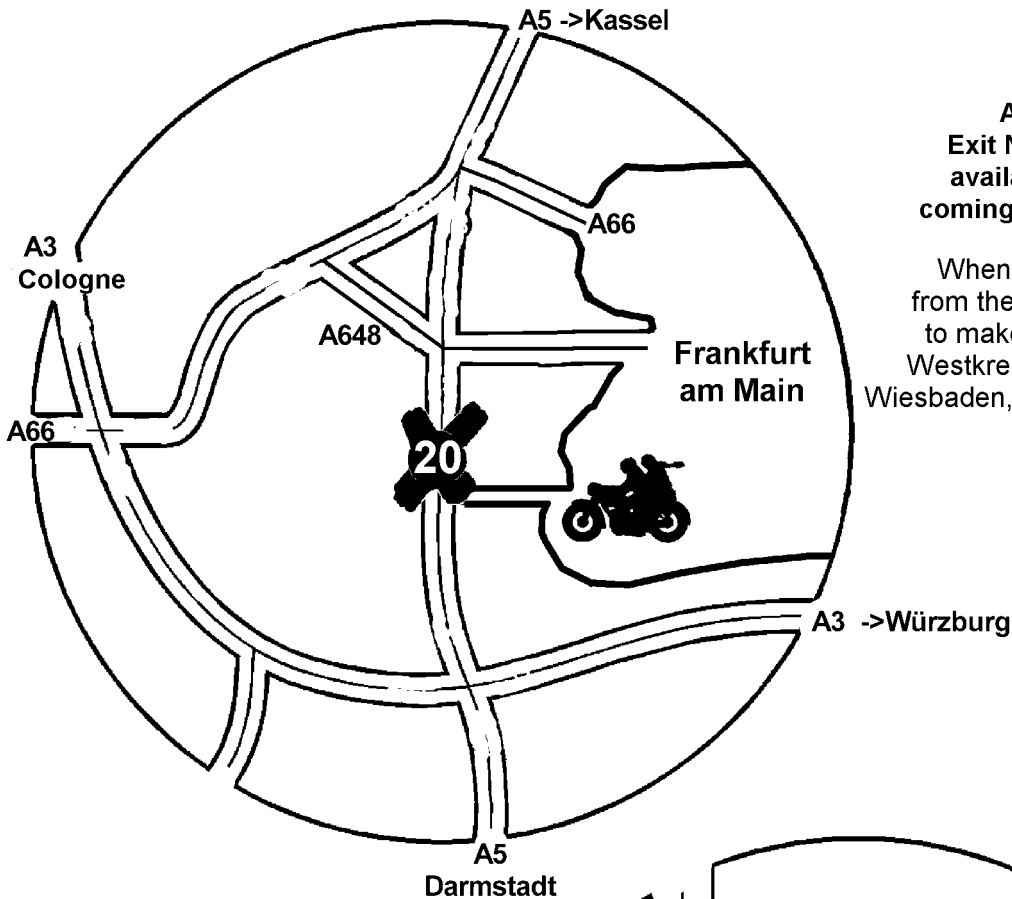

Attention!
Exit No 20 is only available if you're coming from the north

When you're coming from the south, you have to make a u-turn at the Westkreuz. First direction Wiesbaden, then direction Basel

Ulis Motorradladen GmbH

Gutleutstraße 144
D-60327 Frankfurt am Main

Telefon +49 (0) 69 / 23 93 19
Telefax +49 (0) 69 / 23 38 40

Info@UlisMotorradladen.de
www.UlisMotorradladen.de

WGS84
N 50°06.138'
E 008°39.602'

